

DE	Gebrauchsanleitung / Montageanleitung	2
FR	Mode d'emploi / Instructions de montage	3
EN	Instructions for use / assembly instructions	4
IT	Istruzioni per l'uso / Istruzioni per Installazione	5
ES	Modo de empleo / Instrucciones de montaje	6
NL	Gebruiksaanwijzing / Handleiding	7
DK	Brugsanvisning / Monteringsvejledning	8
PT	Instruções para uso / Manual de Instalação	9
PL	Instrukcja obsługi / Instrukcja montażu	10
CS	Návod k použití / Montážní návod	11
SK	Návod na použitie / Montážny návod	12
ZH	用户手册 / 组装说明	13
RU	Руководство пользователя / Инструкция по монтажу	14
HU	Használati útmutató / Szerelési útmutató	15
FI	Käyttöohje / Asennusohje	16
SV	Bruksanvisning / Monteringsanvisning	17
LT	Vartotojo instrukcija / Montavimo instrukcijos	18
HR	Upute za uporabu / Uputstva za instalaciju	19
TR	Kullanım kılavuzu / Montaj kılavuzu	20
RO	Manual de utilizare / Instrucțiuni de montare	21
EL	Οδηγίες χρήσης / Οδηγία συναρμολόγησης	22
SL	Navodilo za uporabo / Navodila za montažo	23
ET	Kasutusjuhend / Paigaldusjuhend	24
LV	Lietošanas pamācība / Montāžas instrukcija	25
SR	Uputstvo za upotrebu / Uputstvo za montažu	26
NO	Bruksanvisning / Montasjeveiledning	27
BG	Инструкция за употреба / Ръководство за монтаж	28
SQ	Udhëzuesi i përdorimit / Udhëzime rreth montimit	29
AR	دليل الاستخدام / تعليمات التجميع	30

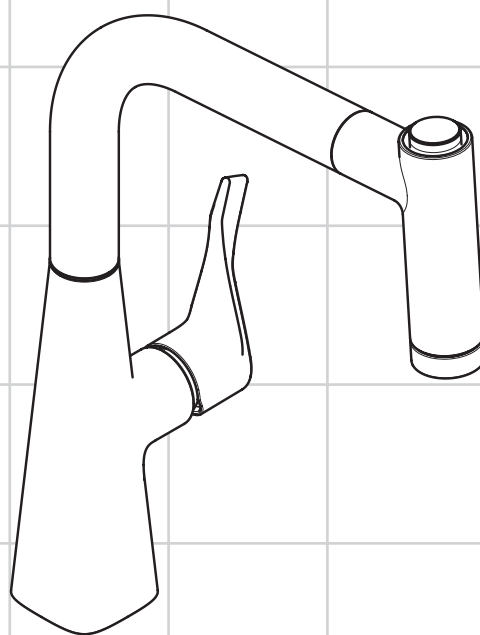

Metris 220
14834000 / 14834800



Sicherheitshinweise

- Bei der Montage müssen zur Vermeidung von Quetsch- und Schnittverletzungen Handschuhe getragen werden.
- Große Druckunterschiede zwischen den Kalt- und Warmwasseranschlüssen müssen ausgeglichen werden.

Montagehinweise

- Vor der Montage muss das Produkt auf Transportschäden untersucht werden. Nach dem Einbau werden keine Transport- oder Oberflächenschäden anerkannt.
- Die Leitungen und die Armatur müssen nach den gültigen Normen montiert, gespült und geprüft werden.
- Die in den Ländern jeweils gültigen Installationsrichtlinien sind einzuhalten.

Technische Daten

Betriebsdruck:	max. 1 MPa
Empfohlener Betriebsdruck:	0,1 - 0,5 MPa
Prüfdruck:	1,6 MPa
(1 MPa = 10 bar = 147 PSI)	
Heißwassertemperatur:	max. 70 °C
Empfohlene Heißwassertemperatur:	65 °C
Thermische Desinfektion:	max. 70 °C / 4 min

Das Produkt ist ausschließlich für Trinkwasser konzipiert!

Symbolerklärung



Kein essigsäurehaltiges Silikon verwenden!



Justierung (siehe Seite 33)

Einstellen der Warmwasserbegrenzung. In Verbindung mit Durchlauferhitzern ist eine Warmwassersperre nicht zu empfehlen.

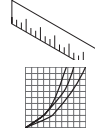

Maße (siehe Seite 34)

Durchflussdiagramm (siehe Seite 34)

- Normalstrahl
- Brausestrahl



Serviceteile (siehe Seite 36)

XXX = Farbcodierung
 000 = chrom
 800 = edelstahl-optik



Bedienung (siehe Seite 34)

- Hansgrohe empfiehlt, morgens oder nach längeren Stagnationszeiten den ersten halben Liter nicht als Trinkwasser zu verwenden.
- Beim Öffnen der Armatur über den Hebelgriff kann kurzzeitig minimal Wasser am Auslauf austreten.



Wartung (siehe Seite 35)

Rückflussverhinderer müssen gemäß DIN EN 1717 regelmäßig in Übereinstimmung mit nationalen oder regionalen Bestimmungen auf ihre Funktion geprüft werden (mindestens einmal jährlich).



Reinigung (siehe Seite 35)



Prüfzeichen (siehe Seite 36)

Störung	Ursache	Abhilfe
Armatur schwergängig	- Kartusche defekt, verkalkt	- Kartusche austauschen
Armatur tropft	- Kartusche defekt	- Kartusche austauschen
Wasseraustritt im Bereich des Schwenkauslaufes	- O-Ring defekt	- O-Ring austauschen
Wasseraustritt am Befestigungsschaft	- Anschlussschläuche nicht ganz in den Grundkörper eingeschraubt	- Anschlussschläuche von Hand festziehen
	- O-Ring am Anschlussschlauch defekt	- O-Ring austauschen
Zu niedrige Warmwassertemperatur	- Warmwasserbegrenzung falsch eingestellt	- Warmwasserbegrenzung einstellen





Consignes de sécurité

- ⚠ Lors du montage, porter des gants de protection pour éviter toute blessure par écrasement ou coupure.
- ⚠ Il est conseillé d'équilibrer les pressions de l'eau chaude et froide.

Instructions pour le montage

- Avant son montage, s'assurer que le produit n'a subi aucun dommage pendant le transport. Après le montage, tout dommage de transport ou de surface ne pourra pas être reconnu.
- Les conduites et la robinetterie doivent être montés, rincés et contrôlés selon les normes en vigueur.
- Les directives d'installation en vigueur dans le pays concerné doivent être respectées.

Informations techniques

Pression de service autorisée:	max. 1 MPa
Pression de service conseillée:	0,1 - 0,5 MPa
Pression maximum de contrôle: (1 MPa = 10 bar = 147 PSI)	1,6 MPa
Température d'eau chaude:	max. 70°C
Température recommandée:	65°C
Désinfection thermique:	max. 70°C / 4 min

Le produit est exclusivement conçu pour de l'eau potable!

Description du symbole



Ne pas utiliser de silicone contenant de l'acide acétique!



Etalonnage (voir pages 33)

Réglage de la limitation d'eau chaude. En liaison avec les chauffe-eau, un blocage de l'eau chaude n'est pas recommandable.



Dimensions (voir pages 34)



Diagramme du débit (voir pages 34)

- ① Jet de pluie
- ② Jet d'eau



Pièces détachées (voir pages 36)

XXX = Couleurs
000 = chromé
800 = aspect acier inox



Instructions de service (voir pages 34)

- Hansgrohe recommande de ne pas utiliser le premier demi-litre le matin ou après une période de stagnation prolongée.
- Lors de l'ouverture de la robinetterie à l'aide du levier, il est possible qu'un léger filet d'eau s'échappe temporairement.



Entretien (voir pages 35)

Les clapets anti-retour doivent être examinés régulièrement conformément à la norme EN 1717 ou conformément aux dispositions nationales ou régionales quant à leur fonction (au moins une fois par an).



Nettoyage (voir pages 35)





Classification acoustique et débit (voir pages 36)

Dysfonctionnement	Origine	Solution
Dureté de fonctionnement	- Cartouche défectueuse, entartrée	- Changer la cartouche
Le mitigeur goutte	- Cartouche défectueuse	- Changer la cartouche
Fuite à l'embase du bec	- Joint torique défectueux	- Changer le joint torique
Fuite à la fixation sous le mitigeur	- Les flexibles de raccordement ne sont pas correctement visser dans le corps. - Joint torique sous les flexible de raccords défectueux	- Resserrer le flexible à la main. - Changer le joint torique
Température d'eau chaude trop basse, pas d'eau froide	- Limiteur de température mal positionné	- Positionner le limiteur de température





Safety Notes

-  Gloves should be worn during installation to prevent crushing and cutting injuries.
-  The hot and cold supplies must be of equal pressures.

Installation Instructions

- Prior to installation, inspect the product for transport damages. After it has been installed, no transport or surface damage will be honoured.
- The pipes and the fixture must be installed, flushed and tested as per the applicable standards.
- The plumbing codes applicable in the respective countries must be observed.

Technical Data

Operating pressure:	max. 1 MPa
Recommended operating pressure:	0,1 - 0,5 MPa
Test pressure:	1,6 MPa
(1 MPa = 10 bar = 147 PSI)	
Hot water temperature:	max. 70 °C
Recommended hot water temp.:	65 °C
Thermal disinfection:	max. 70 °C / 4 min

The product is exclusively designed for drinking water!

Symbol description



Do not use silicone containing acetic acid!



Adjustment (see page 33)

To adjust the hot water limiter. Using a hot water limiter in combination with a continuous flow water heater is not recommended.



Dimensions (see page 34)



Flow diagram (see page 34)

- ① Normal spray
- ② Regular



Spare parts (see page 36)

XXX = Colors
 000 = chrome plated
 800 = stainless steel optic



Operation (see page 34)

- Hansgrohe recommends not to use as drinking water the first half liter of water drawn in the morning or after a prolonged period of non-use.
- Minor leaking may occur briefly at the spout when opening the fitting via the lever.



Maintenance (see page 35)

The check valves must be checked regularly according to DIN EN 1717 in accordance with national or regional regulations (at least once a year).



Cleaning (see page 35)



Test certificate (see page 36)

Fault	Cause	Remedy
Mixer stiff	- Cartridge defective, calcified	- Exchange cartridge
Mixer dripping	- Cartridge defective	- Exchange cartridge
Water escaping in area of swivel spout	- O-ring defective	- Exchange O-ring
Water escaping at the threaded base	- connection hoses not completely screwed into basic body	- Tighten connection hoses by hand
	- O-ring at the connection hose defective.	- Exchange O-ring
Hot water temperature too low	- Hot water limiter incorrectly set	- Set hot water limiter





Indicazioni sulla sicurezza

- ⚠ Durante il montaggio, per evitare ferite da schiacciamento e da taglio bisogna indossare guanti protettivi.
- ⚠ Attenzione! Compensare le differenze di pressione tra i collegamenti dell'acqua fredda e dell'acqua calda.

Istruzioni per il montaggio

- Prima del montaggio è necessario controllare che non ci siano stati danni durante il trasporto. Una volta eseguito il montaggio, non verranno riconosciuti eventuali danni di trasporto o delle superfici.
- Montare, lavare e controllare tubature e rubinetteria rispettando le norme correnti.
- Vanno rispettate le direttive di installazione nazionali vigenti nel rispettivo paese.

Dati tecnici

Pressione d'uso:	max. 1 MPa
Pressione d'uso consigliata:	0,1 - 0,5 MPa
Pressione di prova:	1,6 MPa
(1 MPa = 10 bar = 147 PSI)	
Temperatura dell'acqua calda:	max. 70°C
Temp. dell'acqua calda consigliata:	65°C
Disinfezione termica:	max. 70°C / 4 min

Il prodotto è concepito esclusivamente per acqua potabile!

Descrizione simbolo



Non utilizzare silicone contenente acido acetico!



Taratura (vedi pagg. 33)

Regolazione del limitatore di erogazione d'acqua calda. Un limitatore di erogazione di acqua calda in combinazione con le caldaie istantanee non è consigliabile.

Ingombri (vedi pagg. 34)



Diagramma flusso (vedi pagg. 34)

- ① Getto normale a pioggia
- ② Getto doccia



Parti di ricambio (vedi pagg. 36)

XXX = Trattamento
000 = cromato
800 = acciaio inox acciaio



Procedura (vedi pagg. 34)

- Hansgrohe raccomanda, di mattina oppure dopo lunghi tempi di stagnazione, di non utilizzare il primo mezzo litro come acqua potabile.
- All'apertura del rubinetto tramite la leva, dall'uscita del rubinetto potrebbe fuoriuscire minimamente dell'acqua per breve tempo.



Manutenzione (vedi pagg. 35)

La valvola di non ritorno deve essere controllata regolarmente come da DIN EN 1717, secondo le normative nazionali e regionali (almeno una volta all'anno).



Pulitura (vedi pagg. 35)



Segno di verifica (vedi pagg. 36)

Problema	Possibile causa	Rimedio
Miscelatore duro	- Cartuccia difettosa	- Sostituire la cartuccia
Miscelatore gocciola	- Cartuccia difettosa	- Sostituire la cartuccia
Perdita di acqua intorno all'erogazione girevole	- O-ring difettoso	- Sostituire l'o-ring
Perdita di acqua al set di fissaggio	- I raccordi dei flessibili avvitati male nel corpo incasso	- Avvitare i raccordi flessibili a mano
	- O-ring al raccordo flessibile difettoso	- Sostituire l'o-ring
Temperatura dell'acqua calda	- Limitazione dell'acqua calda regolata male	- Regolare la limitazione dell'acqua calda





Indicaciones de seguridad

- ⚠ Durante el montaje deben utilizarse guantes para evitar heridas por aplastamiento o corte.
- ⚠ Grandes diferencias de presión en servicio entre agua fría y agua caliente deben equilibrarse.

Indicaciones para el montaje

- Antes del montaje se debe examinar el producto contra daños de transporte. Después de la instalación no se reconoce ningún daño de transporte o de superficie.
- Los conductos y la grifería deben montarse, lavarse y comprobarse según las normas vigentes.
- Es obligatorio el cumplimiento de las directrices de instalación vigentes en el país respectivo.

Datos técnicos

Presión en servicio:	max. 1 MPa
Presión recomendada en servicio:	0,1 - 0,5 MPa
Presión de prueba:	1,6 MPa
(1 MPa = 10 bar = 147 PSI)	
Temperatura del agua caliente:	max. 70°C
Temp. recomendada del agua caliente:	65°C
Desinfección térmica:	max. 70°C / 4 min

El producto ha sido concebido exclusivamente para agua potable.

Descripción de símbolos



No utilizar silicona que contiene ácido acético!



Ajuste (ver página 33)

Ajuste del límite de agua caliente. En combinación con calentadores continuos no es recomendable utilizar un bloqueo de agua caliente.



Dimensiones (ver página 34)

Diagrama de circulación (ver página 34)

- ① Chorro de lluvia
- ② Chorro de ducha



Repuestos (ver página 36)

XXX = Acabados
000 = cromado
800 = acero especial



Manejo (ver página 34)

- Hansgrohe recomienda no utilizar el primer medio litro como agua potable por las mañanas o tras un largo periodo de inactividad.
- Al abrir el grifo con la palanca puede derramarse una mínima cantidad de agua por la salida.



Mantenimiento (ver página 35)

Las válvulas anti-retorno tienen que ser controladas regularmente según la norma DIN EN 1717, en acuerdo con las regulaciones nacionales o regionales (una vez al año, por lo menos).



Limpiar (ver página 35)



Marca de verificación (ver página 36)

Problema	Causa	Solución
Manecilla va dura	- cartucho dañado	- cambiar el cartucho
Grifo pierde agua	- cartucho dañado	- cambiar el cartucho
Pérdida de agua en el caño giratorio	- junta dañado	- cambiar juntas
Pérdida de agua en el set de fijación	- Conexión flexible mal atornillada al cuerpo del caño. - Daños en la junta de la conexión flexible	- Apretar a mano la conexión flexible - cambiar juntas
Temperatura del agua caliente demasiado baja	- tope de agua caliente mal	- ajustar tope





Veiligheidsinstructies

- ⚠ Bij de montage moeten ter voorkoming van knel- en snijwonden handschoenen worden gedragen.
- ⚠ Grote drukverschillen tussen de koud- en warmwatertoevoer dienen vermeden te worden.

Montage-instructies

- Vóór de montage moet het product gecontroleerd worden op transportschade. Na de inbouw wordt geen transport- of oppervlakteschade meer aanvaard.
- De leidingen en armaturen moeten gemonteerd, gespoeld en gecontroleerd worden volgens de geldige normen.
- De in de overeenkomstige landen geldende installatierichtlijnen moeten nageleefd worden.

Technische gegevens

Werkdruk: max.

Aanbevolen werkdruk:

Getest bij:

(1 MPa = 10 bar = 147 PSI)

Temperatuur warm water:

Aanbevolen warm water temp.:

Thermische desinfectie:

max. 1 MPa

0,1 - 0,5 MPa

1,6 MPa

max. 70°C

65°C

max. 70°C / 4 min

Het product is uitsluitend ontworpen voor drinkwater!

Symbolbeschrijving



Gebruik geen zuurhoudende silicone!



Instellen (zie blz. 33)

Instellen van de warmwaterbegrenzing. In combinatie met een doorstroomer is een warmwaterblokkering niet aanbevelenswaardig.



Maten (zie blz. 34)



Doorstroombiagram (zie blz. 34)

① Normale douchestraal

② Douchestraal



Service onderdelen (zie blz. 36)

XXX = Kleuren

000 = verchroomd

800 = RVS-look



Bediening (zie blz. 34)

- Hansgrohe raadt aan om 's morgens na langere stagnatietijden de eerste halve liter niet als drinkwater te gebruiken.

- Bij het openen van de armatuur via de hendelgreep kann kort een kleine hoeveelheid water aan de uitloop ontsnappen.



Onderhoud (zie blz. 35)

Keerleppele moeten volgens DIN EN 1717 regelmatig en volgens plaatselijk geldende eisen op het functioneren gecontroleerd worden. (Tenminste een keer per jaar)



Reinigen (zie blz. 35)



Keurmerk (zie blz. 36)

Storing	Oorzaak	Oplossing
Bediening zwaar	- Kardoes defect of verkalkt	- Kardoes uitwisselen
Mengkraan lekt	- Kardoes defect	- Kardoes uitwisselen
Lekkage tussen aansluiting uitloop en kraanhuis	- O-ring defect	- O-ring uitwisselen
Lekkage op montageschacht	- Aansluitslangen niet geheel in kraanhuis vastgedraaid	- Aansluitslangen handvast aandraaien
	- O-ring van aansluitslang defect	- O-ring uitwisselen
Temperatuur van warm water te laag	- Heetwaterbegrenzer verkeerd ingesteld	- Heetwaterbegrenzer instellen



Montage zie blz. 31



Sikkerhedsanvisninger

- ⚠ Ved monteringen skal der bruges handsker for at undgå kvæstelser og snitsår.
- ⚠ Større trykforskelte mellem koldt og varmt vand bør udjævnes.

Monteringsanvisninger

- Før monteringen skal produktet kontrolleres for transportskader. Efter monteringen godkendes transportskader eller skader på overfladen ikke længere.
- Ledningerne og armaturerne skal monteres, skylles og kontrolleres iht. de gældende standarder.
- Installationsbestemmelserne, der gælder i det enkelte land, skal overholdes.

Tekniske data

Driftstryk:	max. 1 MPa
Anbefalet driftstryk:	0,1 - 0,5 MPa
Prøvetryk:	1,6 MPa
(1 MPa = 10 bar = 147 PSI)	
Varmtvandsstemperatur:	max. 70°C
Anbefalet varmtvandsstemperatur:	65°C
Termisk desinfektion:	max. 70°C / 4 min

Produktet er udelukkende beregnet til drikkevand!

Symbolbeskrivelse



Der må ikke benyttes eddikesyreholdig silikone!



Forindstilling (se s. 33)

Indstilling af varmtvandsbegrænsningen. I forbindelse med gennemstrømningsvandvarmere anbefaler vi ikke en varmtvandsspærre.



Målene (se s. 34)

Gennemstrømningsdiagram (se s. 34)

- ① Normalstråle
- ② Brusestråle



Reservedele (se s. 36)

XXX = Overflade
000 = Krom
800 = Stainless steel optic



Brugsanvisning (se s. 34)

- Hansgrohe anbefaler at den første halve liter om morgenen eller efter længere stagneringstider ikke anvendes som drikkevand.
- Når armaturet åbnes med håndgrebet, kan lidt vand strømme ud af udløbet i kort tid.



Service (se s. 35)

Ifølge DIN EN 1717 skal gennemstrømningsbegrænsere i overensstemmelse med nationale regler afprøves regelmæssigt (mindst en gang om året).



Rengøring (se s. 35)



Godkendelse (se s. 36)

Fejl	Årsag	Hjælp
Grebet går trægt	- Kartusche defekt, tilkalket	- Udskift kartusche
Armaturet drypper	- Defekt kartusche	- Udskift kartusche
Armaturet drypper ved svingtuden.	- Defekt o-ring	- Udskift o-ring
Armaturet er utæt ved befæstelsesdelene	- Tilslutningsslangerne er ikke skruet korrekt op i armaturet.	- Med håndkraft skures tilslutningsslangen strammere på.
	- Defekt o-ring på tilslutningsslange	- Udskift o-ring
For lav varmtvands-temperatur	- Varmtvandsbegrænsningen er forkert indstillet	- Indstil varmtvandsbe-grænsningen





Avisos de segurança

- ⚠ Durante a montagem devem ser utilizadas luvas de protecção, de modo a evitar ferimentos resultantes de entalamentos e de cortes.
- ⚠ Grandes diferenças entre as pressões das águas quente e fria devem ser compensadas.

Avisos de montagem

- Antes da montagem deve-se controlar o produto relativamente a danos de transporte. Após a montagem não são aceites quaisquer danos de transporte ou de superfície.
- As tubagens e a torneira têm que ser montadas, enxaguadas e verificadas de acordo com as normas em vigor.
- A prescrições de instalação válidas nos respetivos países devem ser respeitadas.

Dados Técnicos

Pressão de funcionamento:	max. 1 MPa
Pressão de func. recomendada:	0,1 - 0,5 MPa
Pressão testada:	1,6 MPa
(1 MPa = 10 bar = 147 PSI)	
Temperatura da água quente:	max. 70°C
Temp. água quente recomendada:	65°C
Desinfecção térmica:	max. 70°C / 4 min

Este produto foi única e exclusivamente concebido para água potável!

Descrição do símbolo



Não utilizar silicone que contenha ácido acético!



Afinação (ver página 33)

Ajuste do limitador de água quente. Em combinação com um esquentador, não é recomendável o uso de um bloqueio de água quente.



Medidas (ver página 34)



Fluxograma (ver página 34)

- ① operação normal
- ② Chuveiro



Peças de substituição (ver página 36)

XXX = Acabamentos
000 = cromado
800 = aço imaculado ótica



Funcionamento (ver página 34)

- A Hansgrohe recomenda a não utilização do primeiro meio litro de água, de manhã ou após longas paragens, para fins de consumo.
- Durante a abertura da torneira através do manípulo pode ser temporariamente uma pequena quantidade de água.



Manutenção (ver página 35)

As válvulas anti-retorno devem ser verificadas regularmente de acordo com a DIN EN 1717 segundo os regulamentos nacionais ou regionais (pelo menos uma vez por ano).



Limpeza (ver página 35)



Marca de controlo (ver página 36)

Falha	Causa	Solução
Misturadora perra	- Cartucho defeituoso, calcificado	- Substituir o cartucho
Misturadora a pingar	- Cartucho defeituoso	- Substituir o cartucho
Perde água na zona da bica rotativa	- O-ring defeituoso	- Trocar o-ring
Perde água pela base roscada	- Tubos de ligação não estão completamente enroscados	- Apertar os tubos de ligação à mão
	- O-ring dos tubo de ligação defeituoso	- Trocar o-ring
Temperatura da água quente muito baixa	- O limitador de temperatura está incorrectamente colocado	- Regular o limitador de temperatura





Wskazówki bezpieczeństwa

- ⚠ Aby uniknąć zranień na skutek zgniecenia lub przecięcia, podczas montażu należy nosić rękawice ochronne.
- ⚠ Znaczące różnice ciśnień na dopływach ciepłej i zimnej wody muszą zostać wyrównane.

Wskazówki montażowe

- Przed montażem należy skontrolować produkt pod kątem szkód transportowych. Po montażu nie widać żadnych szkód transportowych ani szkód na powierzchni.
- Przewody i armatura muszą być montowane, płukane i kontrolowane według obowiązujących norm.
- Należy przestrzegać wytycznych instalacyjnych obowiązujących w danym kraju.

Dane techniczne

Ciśnienie robocze:

maks. 1 MPa

Zalecane ciśnienie robocze:

0,1 - 0,5 MPa

Ciśnienie próbne:

1,6 MPa

(1 MPa = 10 bary = 147 PSI)

Temperatura wody gorącej:

maks. 70°C

Zalecana temperatura wody gorącej:

65°C

Dezynfekcja termiczna:

maks. 70°C / 4 min

Produkt przeznaczony wyłącznie do wody pitnej!

Opis symbolu



Nie stosować silikonów zawierających kwas octowy!



Ustawianie (patrz strona 33)

Ustawianie ogranicznika ciepłej wody. Używanie ogranicznika temperatury wody w połączeniu z przepływowym podgrzewaczem wody nie jest zalecane.

Wymiary (patrz strona 34)



Schemat przepływu (patrz strona 34)

- ① Strumień normalny
- ② Strumień prysznica



Części serwisowe (patrz strona 36)

XXX = Kody kolorów

000 = chrom

800 = stal szlachetna



Obsługa (patrz strona 34)

- Hansgrohe zaleca, by z rana lub po dłuższym czasie niekorzystania, pierwsze pół litra wody nie używać jako wody pitnej.
- Przy otwieraniu armatury za pomocą uchwytu dźwigniowego przez krótki okres czasu może przy wylocie wydostawać się nieznaczna ilość wody.



Konserwacja (patrz strona 35)

Zgodnie z normą DIN EN 1717, krajowymi i miejscowymi przepisami, działanie zabezpieczeń przed przepływem zwrotnym musi być kontrolowane (przynajmniej raz w roku).



Czyszczenie (patrz strona 35)



Znak jakości (patrz strona 36)

Usterka	Przyczyna	Pomoc
Uchwyt armatury pracuje z wysiłkiem	- Uszkodzony wkład, zakamieniony	- Wymiana wkładu
Armatura cieknie	- Uszkodzony wkład	- Wymiana wkładu
Wyciek wody w obszarze wylewki	- Uszkodzony o-ring	- Wymienić o-ring
Wyciek wody przy mocowaniu od dołu	- Zbyt słabo wkręcone wężyki w korpus - Uszkodzony o-ring przy wężu przyłączeniowym	- Dokręcić wężyki - Wymienić o-ring
Za niska temperatura ciepłej wody	- Niewłaściwe ustawienie ogranicznika ciepłej wody	- Ustawić ogranicznik ciepłej wody





Bezpečnostní pokyny

- Pro zabránění řezným zraněním a pohmožděninám je nutné při montáži nosit rukavice.
- Je nutné vyrovnat velké rozdíly tlaku mezi přípoji studené a teplé vody.

Pokyny k montáži

- Před montáží je třeba produkt zkontrolovat, zda nebyl při transportu poškozen. Po zabudování nebudou uznány žádné škody způsobené transportem nebo poškození povrchu.
- Vedení a armatura musí být namontovány, propláchnuty a otestovány podle platných norem.
- Je třeba dodržovat montážní pravidla platné v dané zemi.

Technické údaje

Provozní tlak:	max. 1 MPa
Doporučený provozní tlak:	0,1 - 0,5 MPa
Zkušební tlak:	1,6 MPa
(1 MPa = 10 bar = 147 PSI)	
Teplota horké vody:	max. 70 °C
Doporučená teplota horké vody:	65 °C
Tepelná desinfekce:	max. 70 °C / 4 min

Výrobky Hansgrohe jsou vhodné pro přímý kontakt s pitnou vodou.

Popis symbolů



Nepoužívat silikon s obsahem kyseliny octové!



Nastavení (viz strana 33)

Nastavení omezovače teplé vody. Ve spojení s průtokovým ohřivačem se použití uzávěru teplé vody nedoporučuje.



Rozměry (viz strana 34)



Diagram průtoku (viz strana 34)

- Normální proud
- Ruční sprcha



Servisní díly (viz strana 36)

XXX = Kód povrchové úpravy
000 = chrom
800 = nerezová ocel



Ovládání (viz strana 34)

- Hansgrohe doporučuje ráno nebo po delších přestávkách nepoužívat prvního půl litru jako pitnou vodu.
- Při otevření armatury páčkovou rukojetí může dojít krátce k výtoku malého množství vody.



Údržba (viz strana 35)

U zpětných ventilů se musí podle DIN EN 1717 v souladu s národními nebo regionálními předpisy testovat jejich funkčnost (alespoň jednou ročně).



Čištění (viz strana 35)



Zkušební značka (viz strana 36)

Porucha	Příčina	Odstranění
Armatura jde ztěžka	- Kartuše je vadná, zanesená vodním kamenem	- Kartuši vyměnit
Armatura odkapává	- Kartuše je vadná	- Kartuši vyměnit
výstup vody v rozsahu otočného výtoku	- O-kroužek je defektní	- vyměnit O-kroužek
výstup vody na upevňovacím násadci	- přípojovací hadice nejsou dostatečně zašroubovány do tělesa	- přípojovací hadice utáhnout rukou
	- O-kroužek na přípojovací hadici je defektní	- vyměnit O-kroužek
Nízká teplota teplé vody	- Špatně nastavená zarážka pro teplou vodu	- Seřídít zarážku pro teplou vodu





Bezpečnostné pokyny

- ⚠ Pri montáži musíte nosiť rukavice, aby ste predišli pomliaždeninám a rezným poraneniam.
- ⚠ Veľké rozdiely v tlaku medzi prípojkami studenej a teplej vody musia byť vyrovnané.

Pokyny pre montáž

- Pred montážou musíte produkt skontrolovať, či nebol počas transportu poškodený. Po zabudovaní nebudú uznané žiadne škody spôsobené transportom alebo poškodenia povrchu.
- Ledningarna och blandaren måste monteras, spolás igenom och kontrolleras enligt de gällande normerna.
- Je potrebné dodržiavať smernice o inštalácii, ktoré sú práve teraz platné v krajinách.

Technické údaje

Prevádzkový tlak:	max. 1 MPa
Doporučený prevádzkový tlak:	0,1 - 0,5 MPa
Skúšobný tlak:	1,6 MPa
(1 MPa = 10 bar = 147 PSI)	
Teplota teplej vody:	max. 70 °C
Doporučená teplota teplej vody:	65 °C
Termická dezinfekcia:	max. 70 °C / 4 min

Výrobok je koncipovaný výhradne pre pitnú vodu!

Popis symbolov



Nepoužívať silikón s obsahom kyseliny octovej!



Nastavenie (viď strana 33)

Nastavenie obmedzenia teplej vody. V spojení s prietokovými ohrievačmi sa neodporúča použitie obmedzovača teplej vody.



Rozmery (viď strana 34)



Diagram prietoku (viď strana 34)

- ① Normálny prúd
- ② Sprchový prúd



Servisné diely (viď strana 36)

XXX = Farebné označenie
000 = chróm
800 = ušľachtilá oceľ



Obsluha (viď strana 34)

- Hansgrohe odporúča ráno a po dlhších dobách odstavky nepoužiť prvého pol litra vody ako pitnú vodu.
- Pri otvorení armatúry prostredníctvom pákovej rukoväte môže na krátku dobu uniknúť minimálne množstvo vody.



Údržba (viď strana 35)

Pri spätných ventiloch sa musí podľa DIN EN 1717 v súlade s národnými alebo regionálnymi predpismi testovať ich funkčnosť (aspoň raz ročne).



Čistenie (viď strana 35)



Osvedčenie o skúške (viď strana 36)

Porucha	Pričina	Pomoc
Armatúra "chodí" ťažko	- Kartúša je poškodená, vápenaté usadeniny	- Vymeniť kartúšu
Z armatúry kvapká voda	- Kartúša je poškodená	- Vymeniť kartúšu
Uhajanie vode ob vrtľivem izlivu	- Chybný O krúžok	- Vymeniť O krúžok
Uhajanie vode ob pritrďilnem nastavku	- Hadice pripojenia nie sú celkom zaskrutkované do základného telesa	- Hadice pripojenia dotiahnuť ručne
	- Chybný O krúžok na pripojovacej hadici	- Vymeniť O krúžok
Nízka teplota teplej vody	- Nesprávne nastavená zarážka na teplú vodu	- Nastavenie zarážky na teplú vodu





安全技巧

- △ 装配时为避免挤压和切割受伤，必须戴上手套。
- △ 冷热水管间过大的压力差必须予以平衡。

安装提示

- 安装前必须检查产品是否受到运输损害。安装后将不认可运输损害或表面损伤。
- 管道和阀门必须根据通用标准进行安装、冲洗和检查。
- 请遵守当地国家现行的安装规定。

技术参数

工作压强:	最大 1 MPa
推荐工作压强:	0,1 - 0,5 MPa
测试压强:	1,6 MPa
(1 MPa = 10 bar = 147 PSI)	
热水温度:	最大 70°C
推荐热水温度:	65°C
热力消毒:	最大 70°C / 4 分钟

该产品专为饮用水设计！

符号说明



请勿使用含有乙酸的硅胶！



调节 (参见第页 33)

热水温度调节。如果使用即热式喷头，则不建议安装热水阀门。



大小 (参见第页 34)



流量示意图 (参见第页 34)

- ① 普通水流
- ② 花洒



备用零件 (参见第页 36)

XXX = 颜色代码
000 = 镀铬
800 = 不锈钢表面



操作 (参见第页 34)

- 汉斯格雅建议，清晨或在水流长时间停滞，前半升水不作饮用水使用。
- 通过手柄打开阀门时出水口可能流出少量水。



保养 (参见第页 35)

单向阀必须在符合国家或当地的法律的情况下按照DIN EN 1717定期检查（至少一年一次）。



清洗 (参见第页 35)



检验标记 (参见第页 36)

问题	原因	补救
龙头不灵活	- 阀芯损坏、结垢	- 更换阀芯
龙头滴水	- 阀芯损坏	- 更换阀芯
水从龙头出水嘴流出	- O形环损坏	- 更换O形环
水从螺纹底座中流出	- 连接软管没有完全旋入基体	- 用手拧紧连接软管
	- 连接软管的O形环损坏	- 更换O形环
热水温度过低	- 温度限制器设置错误	- 设置温度限制器





Указания по технике безопасности

- Во время монтажа следует надеть перчатки во избежание прищемления и порезов.
- донного клапа. Перед установкой смесителя необходимо регулировочными кранами выровнять давление холодной и горячей воды при помощи вентилей регулирующих подачу воды в квартиру.

Указания по монтажу

- Перед монтажом следует проверить изделие на предмет повреждений при перевозке. После монтажа претензии о возмещении ущерба за повреждения при перевозке или повреждения поверхностей не принимаются.
- Трубы и арматура должны быть установлены, промыты и проверены в соответствии с действующими нормами.
- Необходимо соблюдать требования по монтажу, действующие в соответствующих странах.

Технические данные

Рабочее давление:	не более. 1 МПа
Рекомендуемое рабочее давление:	0,1 - 0,5 МПа
Давления:	1,6 МПа
(1 МПа = 10 bar = 147 PSI)	
Температура горячей воды:	не более. 70°С
Рекомендуемая темп. гор. воды:	65°С
Термическая дезинфекция:	не более. 70°С / 4 мин

Изделие предназначено исключительно для питьевой воды!

Описание символов



Не применяйте силикон, содержащий уксусную кислоту.



Подгонка (см. стр. 33)

Регулировка ограничителя горячей воды. В сочетании с проточными нагревателями не рекомендуется использовать блокировку воды.



Размеры (см. стр. 34)



Схема потока (см. стр. 34)

- Нормальная струя
- Струя душа



Комплект (см. стр. 36)

XXX = Цветная кодировка
000 = хром
800 = сталь



Эксплуатация (см. стр. 34)

- Hansgrohe рекомендует по утрам либо после длительного перерыва в использовании не использовать первые поллитра воды для питья.
- Открывая арматуру с помощью рычажной рукоятки, через выпускное отверстие в течение непродолжительного времени может вытекать небольшое количество воды.



Техническое обслуживание (см. стр. 35)

Защита обратного тока должна регулярно проверяться (минимум один раз в год) по стандарту DIN EN 1717 или в соответствии с национальными или региональными нормативами



Очистка (см. стр. 35)



Знак технического контроля (см. стр. 36)

Неисправность	Причина	Устранение неисправности
Арматура работает с усилием	- Картридж неисправен, засорение накипью	- Замените картридж
Арматура протекает	- Картридж неисправен	- Замените картридж
Выход воды в области поворотного выхода	- Уплотнительное кольцо круглого сечения неисправно	- Замените уплотнительное кольцо круглого сечения
Выход воды у основания крепления	- Шланги подключения не полностью завернуты в корпус	- Затяните шланги подключения вручную
	- Уплотнительное кольцо круглого сечения на соединительном шланге неисправно	- Замените уплотнительное кольцо круглого сечения
Температура горячей воды слишком низкая	- Ограничение горячей воды отрегулировано неправильно	- Отрегулируйте ограничение горячей воды





Biztonsági utasítások

- ⚠ A szerelésnél a zúzódások és vágási sérülések elkerülése érdekében kesztyűt kell viselni.
- ⚠ A hidegvíz- és a melegvíz-csatlakozások közötti nagy nyomáskülönbséget kikell egyenlíteni!

Szerelési utasítások

- A szerelés előtt ellenőrizni kell, hogy a terméknek nincs-e szállítási sérülése. Beépítés után a szállítási- vagy felületi sérüléseket nem ismerik el.
- A vezetékeket és a csaptelepet az érvényes szabványoknak megfelelően kell felszerelni, öblíteni és ellenőrizni
- Az egyes országokban érvényes installációs irányelveket be kell tartani.

Műszaki adatok

Üzemi nyomás:	max. 1 MPa
Ajánlott üzemi nyomás:	0,1 - 0,5 MPa
Nyomáspróba:	1,6 MPa
(1 MPa = 10 bar = 147 PSI)	
Forróvíz hőmérséklet:	max. 70 °C
Forróvíz javasolt hőmérséklete:	65 °C
Termikus fertőtlenítés:	max. 70 °C / 4 perc

A terméket kizárólag ivóvízhez tervezték!

Szimbólumok leírása



Ne használjon ecetsavtartalmú szilikont!



Beállítás (lásd a oldalon 33)

A meleg víz korlátozás beállítása. Átfolyós vízmelegítőknél meleg víz korlátozó használata nem ajánlott.



Méretet (lásd a oldalon 34)



Átfolyási diagramm (lásd a oldalon 34)

- ① Normálsugár
- ② Zuhansugár



Tartozékok (lásd a oldalon 36)

XXX = Színkódolás
000 = króm
800 = acéloptika



Használat (lásd a oldalon 34)

- A Hansgrohe azt ajánlja, hogy hosszabb állási idő után az első fél liter vizet ne használja ivóvízként.
- A csaptelep emelőkaron keresztüli megnyitása esetén rövid ideig minimális mennyiségű víz léphet ki a kifolyóból.



Karbantartás (lásd a oldalon 35)

A visszafolyásgátlók működése a DIN EN 1717 szabványnak megfelelően, a nemzeti vagy területi rendelkezésekkel összhangban, évente egyszer ellenőrizendő!



Tisztítás (lásd a oldalon 35)



Vizsgajel (lásd a oldalon 36)

Hiba	Ok	Megoldás
Nehezen nyitható a csap.	- A kerámiabetét meghibásodott, elvízkövesedett.	- A kerámiabetétet ki kell cserélni.
Csöpög a csap.	- A kerámiabetét meghibásodott.	- A kerámiabetétet ki kell cserélni.
Vízkilépés a billenthető kifolyó területén	- Tömítőgyűrű meghibásodott	- Tömítőgyűrű kicserélése
Vízkilépés a rögzítőrúdon	- A csatlakozótömlők nincsenek teljesen becsavarozva az akaptestbe	- A csatlakozótömlőket kézzel meghúzni
	- Csatlakozótömlő tömítőgyűrűje meghibásodott	- Tömítőgyűrű kicserélése
túl alacsony melegvíz hőmérséklet	- A melegvíz szabályozó rosszul van beállítva.	- A melegvíz szabályozót újra be kell állítani.



**Turvallisuusohjeet**

- Asennuksessa on käytettävä käsiineitä puristumien ja viiltojen aiheuttamien tapaturmien estämiseksi.
- Suuret paine-erot kylmä- ja kuumavesiliitäntöjen välillä on tasattava.

Asennusohjeet

- Ennen asennusta on tarkastettava tuotteen mahdolliset kuljetusvahingot. Asennuksen jälkeen kuljetus- ja pintavaurioita ei hyväksytä.
- Putket ja hana on asennettava, huuhdeltava ja tarkastettava voimassa olevien standardien mukaisesti.
- Jokaisessa maassa on noudatettava siellä päteviä asennusohjeita.

Tekniset tiedot

Käyttöpaine:	maks. 1 MPa
Suosittelut käyttöpaine:	0,1 - 0,5 MPa
Koestuspaine:	1,6 MPa
(1 MPa = 10 bar = 147 PSI)	
Kuuman veden lämpötila:	maks. 70 °C
Kuuman veden suosituslämpötila:	65 °C
Lämpödesinfektio:	maks. 70 °C / 4 min

Tuote on suunniteltu käytettäväksi ainoastaan juomaveden kanssa!

Merkin kuvaus

Älä käytä etikkahappopitoista silikonia!

**Säätö** (katso sivu 33)

Lämpötilan rajoittimen säätäminen. Emme suosittele käyttämään lämpötilan rajoitinta vedenlämmittimen (läpivirtauskuumennin) yhteydessä.

**Mitat** (katso sivu 34)**Virtausdiagrammi** (katso sivu 34)

- Normaalisuihku
- Suihku

**Varaosat** (katso sivu 36)

XXX = Värikoodaus
000 = kromi
800 = inox-optinen

**Käyttö** (katso sivu 34)

- Hansgrohe suosittelee, että ensimmäistä puolta litraa ei käytetä juomavetenä aamuisin eikä silloin, kun laitetta ei ole käytetty pitkään aikaan.
- Vettä voi tulla ulos minimaalisesti lyhyen aikaa vesihanauksen aukosta, kun hana avataan vivusta.

**Huolto** (katso sivu 35)

Vastaventtiilien toiminta on tarkastettava säännöllisesti paikallisten ja kansallisten määräysten mukaisesti (DIN EN 1717, vähintään kerran vuodessa).

**Puhdistus** (katso sivu 35)**Koestusmerkki** (katso sivu 36)

Häiriö	Syy	Toimenpide
Hana on raskaskäyttöinen	- Patruuna rikki, kalkkikerrostumia	- Vaihda patruuna
Hanasta tippuu vettä	- Patruuna rikki	- Vaihda patruuna
Vettä valuu kääntyvän juoksuputken juuresta	- O-rengas on rikki	- Vaihda O-rengas
Vettä valuu kiinnityskauluksesta	- Liitosletkut eivät ole kierretty kiinni perusrunkoon pohjaan asti	- Kierrä liitosletkut kiinni käsikireyteen
	- Liitosletkun O-rengas on rikki	- Vaihda O-rengas
Lämminveden lämpötila liian alhainen	- Lämminveden rajoitin väärin säädetty	- Säädä lämminveden rajoitin





⚠ Säkerhetsanvisningar

- ⚠ Handskar ska bäras under monteringsarbetet så att man kan undvika kläm- och skärskadorna.
- ⚠ Stora tryckskillnader mellan anslutningarna för varmt och kallt vatten måste utjämnas.

Monteringsanvisningar

- Det måste undersökas om produkten har transportskador innan den monteras. Efter monteringen accepteras inga transport- eller ytskiktsskador.
- Ledningarna och blandaren måste monteras, spolats igenom och kontrolleras enligt de gällande normerna.
- De installationsriktlinjer som gäller i länderna ska följas.

Tekniska data

Driftstryck:	max. 1 MPa
Rek. driftstryck:	0,1 - 0,5 MPa
Tryck vid provtryckning: (1 MPa = 10 bar = 147 PSI)	1,6 MPa
Varmvattentemperatur:	max. 70 °C
Rek. varmvattentemp.:	65 °C
Termisk desinfektion:	max. 70 °C / 4 min

Produkten är enbart avsedd för dricksvatten!

Symbolförklaring



Använd inte silikon som innehåller ättiksyra!



Justering (se sidan 33)

Ställa in varmvattenregleringen. Tillsammans med varmvattenberedare rekommenderas inte en varmvattenspär.



Måtten (se sidan 34)

Flödesschema (se sidan 34)

- ① Normalstråle
- ② Duschstråle



Reservdelar (se sidan 36)

XXX = Färgkodning
000 = krom
800 = rostfri-optik



Hantering (se sidan 34)

- Hansgrohe rekommenderar att den första halvlitern inte används som dricksvatten på morgonen eller efter längre perioder utan användning.
- När blandaren öppnas med spaken kan det komma lite vatten ur öppningen en kort stund.



Skötsel (se sidan 35)

Backventilens funktion måste kontrolleras regelbundet enligt nationella eller regionala bestämmelser i enlighet med DIN EN 1717 (minst en gång per år).



Rengöring (se sidan 35)



Testsigill (se sidan 36)

Störning	Orsak	Åtgärd
Blandare är trög	- Patron defekt, förkalkad	- Byt ut patron
Blandare droppar	- Patron defekt	- Byt ut patron
Vatten kommer ut vid den svängbara blandaren	- O-ring defekt	- Byt ut O-ring
Vatten kommer ut vid monteringsstaget	- Anslutningsslangar inte helt inskruvade i grundkonstruktionen	- Drag fast anslutningsslangar för hand.
	- O-ring på anslutningsslang defekt	- Byt ut O-ring
Varmvattentemperaturen är för låg	- Varmvattenreglering felaktigt inställd	- Ställ in varmvattenreglering





Saugumo technikos nurodymai

- ⚠ Apsaugai nuo užspaudimo ir išsipjovimo montavimo metu mūvėkite pirštines.
- ⚠ Turi būti išlyginti šalto ir karšto slėgio nelygumai.

Montavimo instrukcija

- Prieš montuojant būtina patikrinti, ar gaminys nebuvo pažeistas transportavimo metu. Sumontavus pretenzijos dėl transportavimo ir paviršiaus pažeidimų nepriimamos.
- Vamzdžiai ir sujungimai turi būti montuojami, plaunami ir tikrinami pagal galiojančias normas.
- Laikykitės atitinkamoje šalyje galiojančių direktyvų dėl įrengimo.

Techniniai duomenys

Darbinis slėgis:	ne daugiau kaip 1 MPa
Rekomenduojamas slėgis:	0,1 - 0,5 MPa
Bandomasis slėgis:	1,6 MPa
(1 MPa = 10 barų = 147 PSI)	
Karšto vandens temperatūra:	ne daugiau kaip 70 °C
Rekomenduojama karšto vandens temperatūra:	65 °C
Terminis dezinfekavimas:	ne daugiau kaip 70 °C / 4 min

Produktas skirtas tik geriamajam vandeniui!

Simbolio aprašymas



Nenaudokite silikono, kurio sudėtyje yra acto rūgšties!



Reguliavimas (žr. psl. 33)

Karšto vandens ribojimas. Kartu su cirkuliaciniais šildytuvais nerekomenduojama naudoti karšto vandens blokavimo įtaisų.



Išmatavimai (žr. psl. 34)



Pralaidumo diagrama (žr. psl. 34)

- ① Normali srovė
- ② Dušo srovė



Atsarginės dalys (žr. psl. 36)

XXX = Spalvos
000 = chrom
800 = plienas



Eksplotacija (žr. psl. 34)

- Naudojant po ilgesnės pertraukos, „Hansgrohe“ rekomenduoja pirmo pusės litro vandens nevertoti kaip geriamojo.
- Atveriant maišytuvą svirtimi, gali ištekėti truputį vandens.



Techninis aptarnavimas (žr. psl. 35)

Atbulinio vožtuvo apsauga privalo būti tikrinama reguliariai (mažiausiai kartą per metus) pagal DIN EN1717 arba pagal galiojančias nacionalines arba regionines normas.



Valymas (žr. psl. 35)



Bandymo pažyma (žr. psl. 36)

Gedimas	Priežastis	Priemonė
Sunkiai sukiojama rankenėlė	- Kasetė pažeista, užkalkėjusi	- Pakeisti kasetę
Maišytuvus praleidžia vandenį	- Kasetė pažeista	- Pakeisti kasetę
Prateka vanduo po čiaupu	- tarpinė pažeista	- tarpinę pakeisti
Prateka vanduo per tvirtinimo kotą	- Prijungimo žarnos nepilnai įsuktos į korpusą - Pajungimo žarnos tarpinė pažeista	- Prijungimo žarnas prisukti ranka - tarpinę pakeisti
Per maža karšto vandens temperatūra	- Neteisingai nustatytas karšto vandens ribotuvus	- Nustatyti karšto vandens ribotuvą





Sigurnosne upute

- Prilikom montaže se radi sprječavanja prignječenja i posjekotina moraju nositi rukavice.
- Velika razlika u pritisku između vruće i hladne vode mora biti izbalansirana.

Upute za montažu

- Prije montaže mora se provjeriti je li proizvod oštećen prilikom transporta. Nakon ugradnje se ne priznaju nikakve reklamacije koje se odnose na površinska i transportna oštećenja.
- Cijevi i armatura moraju biti postavljeni, isprani i testirani prema važećim normama.
- Obvezno se moraju uvažiti propisi o instalacijama koji vrijede u dotičnoj zemlji.

Tehnički podaci

Najveći dopušteni tlak:

Preporučeni tlak:

Probni tlak:

(1 MPa = 10 bar = 147 PSI)

Temperatura vruće vode:

Preporučena temperatura vruće vode:

Termička dezinfekcija:

tlak 1 MPa

0,1 - 0,5 MPa

1,6 MPa

tlak 70°C

65°C

tlak 70°C / 4 min

Proizvod je koncipiran isključivo za pitku vodu!

Opis simbola



Nemojte koristiti silikon koji sadrži octenu kiselinu!



Regulacija (pogledaj stranicu 33)

Namještanje limitera tople vode. U kombinaciji s protočnim bojlerima nije preporučljiva primjena sustava za blokiranje dotoka tople vode.



Mjere (pogledaj stranicu 34)



Dijagram protoka (pogledaj stranicu 34)

① Normalni mlaz

② mlaz



Rezervni dijelovi (pogledaj stranicu 36)

XXX = Boje

000 = krom

800 = plemeniti čelik



Upotreba (pogledaj stranicu 34)

- Hansgrohe preporuča da ujutro ili nakon duljeg nekorištenja prvih 1/2 litre vode ne upotrebljavate za piće.
- Pri otvaranju slavine uz pomoć polužne ručke na ispustu može kratkotrajno iscuriti manja količina vode.



Održavanje (pogledaj stranicu 35)

Ispravnost nepovratnog ventila mora se redovito provjeravati prema standardu DIN EN 1717 i u skladu sa važećim propisima (najmanje jednom godišnje).



Čišćenje (pogledaj stranicu 35)



Oznaka testiranja (pogledaj stranicu 36)

Greška	Uzrok	Otklanjanje
Ručica se zaglavila	- Neispravan uložak - Taloženje kamenca	- Zamijenite uložak
Slavina kaplje	- Neispravan uložak	- Zamijenite uložak
Voda izlazi u području rotirajućih dijelova slavine	- O-prsten je neispravan	- Zamijenite O-prsten
Voda izlazi na dijelu gdje je slavina učvršćena	- Priključna crijeva nisu potpuno učvršćena na tijelo - O-prsteni priključnih crijeva su neispravni	- Priključna crijeva učvrstite rukom - Zamijenite O-prsten
Preniska temperatura tople vode	- Limiter vruće vode nije dobro podešen	- Podesite limiter vruće vode





⚠ Güvenlik uyarıları

- ⚠ Montaj esnasında ezilme ve kesilme gibi yaralanmaları önlemek için eldiven kullanılmalıdır.
- ⚠ Sıcak ve soğuk su bağlantıları arasında büyük basınç farklılıkları varsa, bu basınç farklılıklarının dengelenmesi gerekir.

Montaj açıklamaları

- Montaj işleminden önce ürün nakliye hasarları yönünden kontrol edilmelidir. Montaj işleminden sonra nakliye veya yüzey hasarları için sorumluluk üstlenilmemektedir.
- Boruların ve armatürün montajı, yıkanması ve kontrolü geçerli normlara göre yapılmalıdır.
- Ülkelerde geçerli kurulum yönetmeliklerine riayet edilmelidir.

Teknik bilgiler

İşletme basıncı:
Tavsiye edilen işletme basıncı:
Kontrol basıncı:
(1 MPa = 10 bar = 147 PSI)
Sıcak su sıcaklığı:
Tavsiye edilen su ısısı:
Termik dezenfeksiyon:

azami 1 MPa
0,1 - 0,5 MPa
1,6 MPa

azami 70°C
65°C
azami 70°C / 4 dak

Ürün sadece şebeke suyu için tasarlanmıştır!

Simge açıklaması



Asetik asit içeren silikon kullanmayın!



Ayarlama (bakınız sayfa 33)

Sıcak su sınırlamasının ayarlanması. Sıcak su kilidinin sürekli ısıtıcıyla kullanılması tavsiye edilmez.



Ölçüleri (bakınız sayfa 34)



Akış diyagramı (bakınız sayfa 34)

- ① Normal duş
- ② Püskürtme başlığı



Yedek Parçalar (bakınız sayfa 36)

XXX = Renkler
000 = krom
800 = paslanmaz çelik - optik



Kullanımı (bakınız sayfa 34)

- Hansgrohe sabahları uzun durgunluk süresi sonrasında ilk yarım litre suyun içme suyu olarak kullanılmamasını önerir.
- Armatürü kol üzerinden açarken çıkış kısmından kısa süre az miktarda su çıkabilir



Bakım (bakınız sayfa 35)

DIN EN 1717 ve ulusal standartlar doğrultusunda Çek valfler düzenli olarak kontrol edilmelidir. (en az yılda bir kez)



Temizleme (bakınız sayfa 35)



Kontrol işareti (bakınız sayfa 36)

arıza	sebebi	yardım
Batarya kullanımı ağırlaşıyor	- Kartuş Bozulmuş ve kireçlenmiş olabilir	- Kartuşu değiştirin
Batarya su damlatıyor	- Kartuş bozuk olabilir	- Kartuşu değiştirin
Döner çıkış bölgesinden su çıkışı	- O-ring arızalı	- O-ringi değiştirin
Sabitlenme kutusundan su çıkışı	- Bağlantı hortumları ana gövdeye tamamen vidalanmamış	- Bağlantı hortumlarını elinizle sıkın
	- Bağlantı hortumundaki O-ring arızalı	- O-ringi değiştirin
Sıcak suyun derecesi çok düşük	- Isı limitleyici düzgün çalışmıyor	- Isı limitleyiciyi yeniden ayarlayın





Instrucțiuni de siguranță

- ⚠ La montare utilizați mănuși pentru evitarea contuziunilor și tăierii mâinilor.
- ⚠ Diferențele de presiune mari între alimentarea cu apă rece și apă caldă trebuie echilibrate.

Instrucțiuni de montare

- Înainte de instalare verificați, dacă produsul prezintă deteriorări de transport. După instalare garanția nu acoperă deteriorările de transport și cele de suprafață.
- Conductele și bateriile trebuie montate, spălate și verificate conform normelor în vigoare.
- Respectați reglementările referitoare la instalare valabile în țara respectivă.

Date tehnice

Presiune de funcționare:	max. 1 MPa
Presiune de funcționare recomandată:	0,1 - 0,5 MPa
Presiune de verificare:	1,6 MPa
(1 MPa = 10 bar = 147 PSI)	
Temperatura apei calde:	max. 70 °C
Temperatura recomandată a apei calde:	65 °C
Dezinfecție termică:	max. 70 °C / 4 min

Produsul este destinat exclusiv pentru apă potabilă.

Descrierea simbolurilor



Nu utilizați silicon cu conținut de acid acetic!



Reglare (vezi pag. 33)

Reglarea limitatorului de apă caldă. Nu se recomandă folosirea unui limitator de apă caldă în combinație cu un boiler instant.



Dimensiuni (vezi pag. 34)

Diagrama de debit (vezi pag. 34)

- ① jet normal
- ② Cap de jet



Piese de schimb (vezi pag. 36)

XXX = Coduri de culori
000 = crom
800 = oțel inoxidabil



Utilizare (vezi pag. 34)

- Hansgrohe vă recomandă, ca dimineața sau după perioade mai lungi de pauză să nu folosiți prima jumătate de litru de apă pentru băut.
- La deschiderea robinetului de la mâner pot apărea scurgeri minime de apă la ieșirea robinetului.



Întreținere (vezi pag. 35)

Supapele antiretur trebuie verificate regulat conform DIN EN 1717 și standardele naționale sau regionale (cel puțin o dată pe an).



Curățare (vezi pag. 35)



Certificat de testare (vezi pag. 36)

Deranjament	Cauza	Măsuri de remediere
Bateria se mișcă dificil	- Cartuș defect din cauza depunerilor de calcar	- Schimbați cartușul.
Bateria picură	- Cartuș defect	- Schimbați cartușul.
Scurgere de apă în zona pipei rabatabile.	- Inel O defect	- Schimbați inelul O.
Scurgere de apă la șaftul de fixare.	- Furtunurile de racordare nu sunt bine înșurubate în corpul bateriei.	- Strângeți cu mâna furtunurile de racordare.
	- Inelul O de la furtunul de racord defect	- Schimbați inelul O.
Temperatura apei calde este prea mică	- Limitarea temperaturii apei calde setată incorect.	- Setați limitarea temperaturii apei calde.



**Υποδείξεις ασφαλείας**

- ⚠ Για να αποφύγετε τραυματισμούς κατά τη συναρμολόγηση πρέπει να φοράτε γάντια.
- ⚠ Οι διαφορές της πίεσης μεταξύ της σύνδεσης κρύου και ζεστού νερού θα πρέπει να αντισταθμίζονται.

Οδηγίες συναρμολόγησης

- Πριν τη συναρμολόγηση πρέπει να εξεταστεί το προϊόν για ζημιές μεταφοράς. Μετά την εγκατάσταση δεν αναγνωρίζονται ζημιές από τη μεταφορά ή επιφανειακές ζημιές.
- Οι σωλήνες και η μπαταρία πρέπει να τοποθετηθούν σύμφωνα με τα ισχύοντα πρότυπα, να τεθούν υπό πίεση και να δοκιμαστούν.
- Θα πρέπει να τηρούνται οι οδηγίες εγκατάστασης που ισχύουν σε κάθε κράτος.

Τεχνικά Χαρακτηριστικά

Λειτουργία πίεσης:

Συνιστώμενη λειτουργία πίεσης:

Πίεση ελέγχου:

(1 MPa = 10 bar = 147 PSI)

Θερμοκρασία ζεστού νερού:

Συνιστώμενη θερμοκρασία ζεστού νερού:

Θερμική απολύμανση:

έως 1 MPa

0,1 - 0,5 MPa

1,6 MPa

έως 70°C

65°C

έως 70°C / 4 min

Το προϊόν έχει σχεδιαστεί αποκλειστικά για πόσιμο νερό!

Περιγραφή συμβόλων

Μην χρησιμοποιείτε σιλικόνη που περιέχει οξικό οξύ!

**Ρύθμιση** (βλ. Σελίδα 33)

Ρύθμιση του δοσομετρητή ζεστού νερού. Δεν συνιστάται η διάταξη φραγής ζεστού νερού σε συνδυασμό με ταχυθερμοσίφωνα.

**Διαστάσεις** (βλ. Σελίδα 34)**Διάγραμμα ροής** (βλ. Σελίδα 34)

- ① Κανονική δέσμη νερού
- ② Δέσμη καταιονισμού

**Ανταλλακτικά** (βλ. Σελίδα 36)

XXX = Χρώματα

000 = Επιχρωμωμένο

800 = οπτική ανοξείδωτου χάλυβα

**Χειρισμός** (βλ. Σελίδα 34)

- Η Hansgrohe συνιστά το πρωί ή μετά από μεγάλα χρονικά διαστήματα αχρησίας να μην χρησιμοποιείτε το πρώτο μισό λίτρο νερό σαν πόσιμο.
- Κατά το άνοιγμα της λαβής της μπαταρίας μπορεί να τρέξει από το ρουζούνι πολύ σύντομα λίγο νερό.

**Συντήρηση** (βλ. Σελίδα 35)

Οι βαλβίδες αντεπιστροφής πρέπει να ελέγχονται τακτικά ως προς τη λειτουργία τους, σύμφωνα με το πρότυπο DIN EN 1717, σε σχέση με τους ισχύοντες εθνικούς ή τοπικούς κανόνες (το ελάχιστο μια φορά το χρόνο).

**Καθαρισμός** (βλ. Σελίδα 35)**Σήμα ελέγχου** (βλ. Σελίδα 36)

Βλάβη	Αιτία	Διόρθωση
Σκληρή μπαταρία (μείκτης)	- Ελαττωματικό φυσιγγίο, άλατα	- Αλλαγή φυσιγγίου
Η μπαταρία στάζει	- Ελαττωματικό φυσιγγίο	- Αλλαγή φυσιγγίου
Διαρροή νερού στην περιοχή του περιστρεφόμενου ρουζουνιού.	- Ελαττωματικός στρογγυλός δακτύλιος	- Αλλάξτε το στρογγυλό δακτύλιο
Διαρροή νερού στον άξονα στερέωσης	- Οι σωλήνες σύνδεσης δεν είναι πλήρως βιδωμένοι στο βασικό κορμό - Ο στρογγυλός δακτύλιος στο σωλήνα σύνδεσης είναι ελαττωματικός	- Σφίξτε τους σωλήνες σύνδεσης με το χέρι - Αλλάξτε το στρογγυλό δακτύλιο
Χαμηλή θερμοκρασία ζεστού νερού	- Λάθος ρύθμιση της περιοριστικής διάταξης ζεστού νερού	- Ρυθμίστε την περιοριστική διάταξη του ζεστού νερού





Varnostna opozorila

- ⚠ Pri montaži je treba nositi rokavice, da se preprečijo poškodbe zaradi zmečkavanja ali urezov.
- ⚠ Velike razlike v tlaku med priključkom za mrzlo in priključkom za toplo vodo je potrebno izravnati.

Navodila za montažo

- Pred montažo je treba izdelek preveriti glede morebitnih transportnih poškodb. Po vgradnji transportne ali površinske poškodbe ne bodo več priznane.
- Cevi in armaturo je treba montirati, izprati in preveriti po veljavnih standardih.
- Upoštevati je treba pravilnike o inštalacijah, ki veljajo v posamezni državi.

Tehnični podatki

Delovni tlak:	maks. 1 MPa
Priporočeni delovni tlak:	0,1 - 0,5 MPa
Preskusni tlak:	1,6 MPa
(1 MPa = 10 bar = 147 PSI)	
Temperatura tople vode:	maks. 70 °C
Priporočena temperatura tople vode:	65 °C
Termična dezinfekcija:	maks. 70 °C / 4 min

Proizvod je zasnovan izključno za sanitarno vodo!

Opis simbola



Ne smete uporabiti silikona, ki vsebuje očetno kislino!



Justiranje (glejte stran 33)

Nastavitev omejevalnika tople vode. V povezavi s pretočnimi grelniki uporaba zapore tople vode ni priporočljiva.



Mere (glejte stran 34)



Diagram pretoka (glejte stran 34)

- ① Normalen curek
- ② Pršilni curek



Rezervni deli (glejte stran 36)

XXX = Barve
000 = krom
800 = videz legiranega jekla



Upravljanje (glejte stran 34)

- Hansgrohe priporoča, da zjutraj ali po daljšem času stagnacije prvega pol litra vode ne uporabite kot pitno vodo.
- Pri odpiranju armature z ročico lahko na iztoku na kratko izstopi nekoliko vode.



Vzdrževanje (glejte stran 35)

Delovanje protipovratnega ventila je potrebno v skladu z DIN EN 1717 in skladno z državnimi in regionalnimi določili redno testirati (najmanj enkrat letno).



Čiščenje (glejte stran 35)



Preskusni znak (glejte stran 36)

Napaka	Vzrok	Pomoč
Težko premikanje armature	- Pokvarjen vložek, poapneno	- Zamenjajte vložek
Iz armature kaplja	- Pokvarjen vložek	- Zamenjajte vložek
Uhajanje vode ob vrtljivem izlivu	- Obročno tesnilo je pokvarjeno	- Zamenjajte obročno tesnilo
Uhajanje vode ob pritrdilnem nastavku	- Priključne cevi niso popolnoma privijačene v osnovno ogrodje	- Ročno zatisnite priključne cevi
	- Obročna tesnila priključnih gibkih cevi so pokvarjena	- Zamenjajte obročno tesnilo
Prenizka temperatura tople vode	- Omejevalnik tople vode ni pravilno nastavljen	- Nastavite omejevalnik tople vode



**Ohutusjuhised**

- ⚠ Kandke paigaldamisel muljumis- ja löikevigastuste vältimiseks kindaid.
- ⚠ Kui külma ja kuuma vee ühenduste surve on väga erinev, tuleb need tasakaalustada.

Paigaldamisjuhised

- Enne paigaldamist tuleb toodet kontrollida transpordikahjustuste osas. Pärast paigaldamist ei tunnustata enam transpordi- või pinnakahjustuste kaebuseid.
- Voolikute ja segisti paigaldamisel, loputamisel ja kontrollimisel tuleb lähtuda kehtivatest normatiividest.
- Vastavas riigis kehtivaid paigalduseeskirju tuleb järgida.

Tehnilised andmed

Töörõhk	maks. 1 MPa
Soovitatav töörõhk:	0,1 - 0,5 MPa
Kontrollsurve:	1,6 MPa
(1 MPa = 10 baari = 147 PSI)	
Kuuma vee temperatuur:	maks. 70 °C
Soovitatav kuuma vee temperatuur:	65 °C
Termiline desinfitatsioon:	maks. 70 °C / 4 min

Toode on ette nähtud eranditult joogivee jaoks!

Sümbolite kirjeldus

Ärge kasutage äädikhapet sisaldavat silikooni!

**Reguleerimine** (vt lk 33)

Sooja vee piirangu seadistamine. Ühenduses boileritega ei ole sooja vee blokeeringu soovitatav.

**Mõõtude** (vt lk 34)**Läbivooludiagramm** (vt lk 34)

- 1 tavajuga
- 2 Duši juga

**Varuosad** (vt lk 36)

XXX = Värvid
000 = kroom
800 = roostevaba optik

**Kasutamine** (vt lk 34)

- Hansgrohe soovib mitte kasutada esimest poolt liitrit hommikuti või pärast pikemat seisakuaega joogiveena.
- Armatuuri avamisel käepidemest võib lühikese aja jooksul tulla väga vähe vett.

**Hooldus** (vt lk 35)

Tagasilöögiklappide toimimist tuleb kooskõlas riiklike ja regionaalsete määrustega regulaarselt kontrollida vastavalt standardile DIN EN 1717 (vähemalt kord aastas).

**Puhastamine** (vt lk 35)**Kontrollsertifikaat** (vt lk 36)

Rike	Põhjus	Lahendus
Segisti käib raskelt	- Tööelement on katkine, lubjastunud	- Vahetage tööelement
Segisti tilgub	- Tööelement on katkine	- Vahetage tööelement
Veeleke pööratavas jooksutorus	- O-rõngastihend on katki	- Vahetage O-rõngastihend
Veeleke kinnituse juures	- Ühendusvoolikud ei ole korralikult põhikorpuse külge kruvitud	- Kruvige ühendusvoolikud käega kinni
	- Ühendusvoolikute O-rõngastihendid katki	- Vahetage O-rõngastihend
Sooja vee temperatuur liiga madal	- Kuuma vee piirang valesti seatud	- Seadke kuuma vee piirang





Drošības norādes

- Montāžas laikā, lai izvairītos no saspiedumiem un iegriezumiem, nepieciešams nēsāt cimdus.
- Jāizlīdzina spiediena atšķirības starp aukstā un karstā ūdens pievadiem.

Norādījumi montāžai

- Pirms montāžas nepieciešams pārbaudīt, vai produktam transportēšanas laikā nav radušies bojājumi. Pēc iebūvēšanas bojājumi, kas radušies transportēšanas laikā, vai virsmas bojājumi netiek atzīti.
- Cauruļvadi un armatūra ir jāuzstāda, jāizskalo un jāpārbauda saskaņā ar spēkā esošajiem standartiem.
- Jāievēro attiecīgās valstīs spēkā esošās montāžas prasības.

Tehniskie dati

Darba spiediens:	maks. 1 MPa
Ieteicamais darba spiediens:	0,1 - 0,5 MPa
Pārbaudes spiediens:	1,6 MPa
(1 MPa = 10 bar = 147 PSI)	
Karstā ūdens temperatūra:	maks. 70 °C
Ieteicamā karstā ūdens temperatūra:	65 °C
Termiskā dezinfekcija :	maks. 70 °C / 4 min

Izstrādājums ir paredzēts tikai dzeramajam ūdenim!

Simbolu nozīme



Neizmantot silikonu, kas satur etiķskābi!



Ieregulēšana (skat. lpp. 33)

Karstā ūdens ierobežotāja regulēšana. Kopā ar caurteces sildītājiem nav ieteicams izmantot ūdens bloķētāju.



Izmērus (skat. lpp. 34)

Caurplūdes diagramma (skat. lpp. 34)

- Standarta strūkļa
- Dušas strūkļa



Rezerves daļas (skat. lpp. 36)

XXX = Krāsu kodi
000 = hroma
800 = tērauda



Lietošana (skat. lpp. 34)

- Hansgrohe iesaka no rīta vai pēc ilgākiem pārtraukumiem nelietot pirmo puslitru ūdens dzeršanai.
- Atvērot armatūru aiz sviras roktura no izplūdes neilgu laiku var izplūst neliels ūdens daudzums.



Apkope (skat. lpp. 35)

Regulāri jāpārbauda pretvārsta funkcija saskaņā ar DIN EN 1717 saistībā ar nacionālajiem vai vietējiem noteikumiem (vismaz vienreiz gadā).



Tīrīšana (skat. lpp. 35)



Pārbaudes zīme (skat. lpp. 36)

Traucējums	Iemesls	Bojājumu novēršana
Jaucējkrāns smagi grozāms	- Bojāta kartuša, aizkalķojusies	- Nomainīt kartušu
Jaucējkrāns pil	- Bojāta kartuša	- Nomainīt kartušu
Ūdens noplūde grozāmās iztekas rajonā	- Bojāts O-gredzens	- Nomainīt O-gredzenu
Ūdens noplūde pie nostiprinājuma	- Pieslēguma šļūtenes nav līdz galam ieskrūvētas pamatelementā	- Pieslēguma šļūtenes ar roku pievilkt stingrāk
	- Bojāti pieslēguma šļūtenju O-gredzeni	- Nomainīt O-gredzenu
Pārāk zema ūdens temperatūra	- Nepareizi noregulāta karstā ūdens bloķēšana	- Noregulēt karstā ūdens ierobežošanu





Sigurnosne napomene

- ⚠ Prilikom montaže se radi sprečavanja prignječenja i posekotina moraju nositi rukavice.
- ⚠ Velika razlika u pritisku između vruće i hladne vode mora biti izbalansirana.

Instrukcije za montažu

- Pre montaže se mora proveriti da li je proizvod oštećen pri transportu. Nakon ugradnje se ne priznaju nikakve reklamacije koje se odnose na površinska i transportna oštećenja.
- Vodovi i armatura moraju biti postavljeni, isprani i testirani prema važećim normama.
- Treba se pridržavati propisa koji u određenim zemljama važe za instalacije.

Tehnički podaci

Radni pritisak:	maks. 1 MPa
Preporučeni radni pritisak:	0,1 - 0,5 MPa
Probni pritisak:	1,6 MPa
(1 MPa = 10 bar = 147 PSI)	
Temperatura vruće vode:	maks. 70 °C
Preporučena temperatura vruće vode:	65 °C
Termička dezinfekcija:	maks. 70 °C / 4 min

Proizvod je koncipiran isključivo za pijaću vodu!

Opis simbola



Nemojte koristiti silikon koji sadrži sirćetnu kiselinu!



Podešavanje (vidi stranu 33)

Podešavanje ograničavača tople vode. U kombinaciji sa protočnim bojlerima ne preporučuje se primena sistema za blokiranje dotoka tople vode.

Mere (vidi stranu 34)

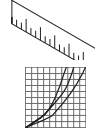

Dijagram protoka (vidi stranu 34)

- ① Normalni mlaz
- ② mlaz



Rezervni delovi (vidi stranu 36)

XXX = Oznake boja

000 = hrom

800 = dezen plemeniti čelik



Rukovanje (vidi stranu 34)

- Hansgrohe preporučuje da ujutru ili nakon dužeg nekorisćenja prvih pola litre vode ne koristite za piće.
- Prilikom otvaranja slavine uz pomoć poluzne ručke na ispustu može kratkotrajno iscuriti manja količina vode.



Održavanje (vidi stranu 35)

Ispravno funkcionisanje nepovratnog ventila se mora redovno proveravati prema standardu DIN EN 1717 i u skladu s važećim nacionalnim ili regionalnim propisima (najmanje jednom godišnje).



Čišćenje (vidi stranu 35)



Ispitni znak (vidi stranu 36)

Smetnja	Uzrok	Pomoć
Ručica se zaglavila	- Neispravna kartuša, nataloženi kamenac	- Zamenite kartušu
Slavina kaplje	- Neispravna kartuša	- Zamenite kartušu
Voda izlazi u zglobu slavine	- O prsten je neispravan	- Zamenite O prsten
Voda izlazi na delu gde je slavina učvršćena	- Priključna creva nisu potpuno učvršćena na telo - O prstenovi priključnih creva su neispravni	- Priključna creva učvrstite rukom - Zamenite O prsten
Preniska temperatura tople vode	- Ograničavač vruće vode nije dobro podešen	- Podesite ograničavač vruće vode





Sikkerhets henvisninger

- △ Bruk hansker under montasjen for å unngå klem- og kuttskader.
- △ Store trykkdifferanser mellom kaldt- og varmtvannstilkoblinger skal utlignes.

Montage henvisninger

- Før montasjen skal produktet sjekkes for transportskader. Etter monteringen aksepteres ikke noen transport- eller overflateskader.
- Ledningene og armaturen skal monteres, spyles og sjekkes iht. de gyldige normer.
- Gjeldende retningslinjer for rørleggerarbeid i de enkelte land skal følges.

Tekniske data

Driftstrykk	maks. 1 MPa
Anbefalt driftstrykk:	0,1 - 0,5 MPa
Prøvetrykk	1,6 MPa
(1 MPa = 10 bar = 147 PSI)	
Varmtvannstemperatur	maks. 70 °C
Anbefalt temperatur for varmt vann	65 °C
Termisk desinfisering:	maks. 70 °C / 4 min

Produktet er utelukkende designet for drikkevann!

Symbolbeskrivelse



Ikke bruk silikon som inneholder eddiksyre!



Justering (se side 33)

Innstilling av varmtvannsbegrensning. I forbindelse med gjennomstrømningsvarmere er det ikke anbefalt å bruke en varmtvannssperre.



Mål (se side 34)



Gjennomstrømningsdiagram (se side 34)

- ① Normalstråle
- ② Dusjstråle



Servicedeler (se side 36)

XXX = Fargekode
000 = krom
800 = rustfritt stål optikk



Betjening (se side 34)

- Om morgen og etter lengre stagnasjonstider anbefaler Hansgrohe å ikke bruke den første halvliteren som drikkevann.
- Ved åpning av armaturen via hendelhåndtaket kan det for en kort stund komme ut vann fra avløpet.



Vedlikehold (se side 35)

Funksjonen til returløpssperren skal iht. DIN EN 1717 og i samsvar med de nasjonale og lokale forskrifter sjekkes regelmessig.



Rengjøring (se side 35)



Prøvemerket (se side 36)

Feil	Årsak	Feilrettelse
Armatur ikke lett bevegelig	- Kartusj defekt, forkalkning	- Kartusj byttes
Armatur drypper	- Kartusj defekt	- Kartusj byttes
Vannlekkasje i området for svingutløpet	- O-ring defekt	- O-ring byttes
Vannlekkasje på festeskaft	- Tilkoblingslanger ikke skrudd helt inn i basiselement - O-ring på tilkoblingslanger defekt	- Tilkoblingslanger trekkes fast fra hånd - O-ring byttes
For lav varmtvannstemperatur	- Varmtvannsbegrensning er feil innstilt	- Varmtvannsbegrensning innstilles





Указания за безопасност

- При монтажа трябва да се носят ръкавици, за да се избегнат наранявания поради притискане или порязване.
- Големите разлики в налягането между изводите за студената и топлата вода трябва да се изравняват.

Указания за монтаж

- Преди монтажа продуктът трябва да се провери за транспортни щети. След монтажа не се признават транспортни или повърхностни щети.
- Тръбопроводите и арматурата трябва да се монтират, промият и проверят в съответствие с валидните норми.
- Трябва да бъдат спазвани валидните в съответните страни предписания за инсталиране.

Технически данни

Работно налягане:	макс. 1 МПа
Препоръчително работно налягане:	0,1 - 0,5 МПа
Контролно налягане: (1 МПа = 10 bar = 147 PSI)	1,6 МПа
Температура на горещата вода:	макс. 70 °С
Препоръчителна температура на горещата вода:	65 °С
Термична дезинфекция:	макс. 70 °С / 4 мин

Продуктът е разработен само за питейна вода!

Описание на символите



Не използвайте силикон, съдържащ оцетна киселина!



Юстиране (вижте стр. 33)

Настройка на ограничителя за топлата вода. Във връзка с проточни нагреватели не се препоръчва блокировка за топлата вода



Размери (вижте стр. 34)



Диаграма на потока (вижте стр. 34)

- Нормална струя
- Разпръскваща струя



Сервизни части (вижте стр. 36)

XXX = Цветово кодиране
000 = хром
800 = оптика на благородна стомана



Обслужване (вижте стр. 34)

- Hansgrohe препоръчва, сутрин и след по-продължително спиране първият половин литър да не се използва като питейна вода.
- При отваряне на арматурата през дръжката на лоста за кратко време от изходящия крайник може да изтече минимално количество вода.



Поддръжка (вижте стр. 35)

Съгласно DIN EN 1717 функционирането на приспособленията за предотвратяване на обратния поток трябва редовно да се проверява в съответствие с националните или регионални изисквания (поне веднъж годишно).



Почистване (вижте стр. 35)



Контролен знак (вижте стр. 36)

Неизправност	Причина	Помощ
Трудно подвижна арматура	- Дефектна гилза, покрита с варовик	- Сменете гилзата
Арматурата капе	- Дефектна гилза	- Сменете гилзата
Избиване на вода в областта на завъртащия се изходящ крайник	- Дефектен О-образен пръстен	- Смяна на О-образен пръстен
Избиване на вода от закрепващата шийка	- Свързващите маркучи не са напълно завинтени в основното тяло	- Затегнете на ръка свързващите маркучи
	- Дефектен О-образен пръстен на свързващия маркуч	- Смяна на О-образен пръстен
Твърде ниска температура на водата	- Ограничението за топлата вода е грушно настроена	- Настройте ограничението за топлата вода





Udhëzime sigurie

- △ Për të evituar lëndimet e pickimeve ose të prerjeve gjatë procesit të montimit duhet që të vishni doreza.
- △ Ndryshimet e mëdha të presionit mes lidhjeve të ujit të ftohtë dhe atij të ngrohtë duhen ekuilibruar.

Udhëzime për montimin

- Përpara montimit duhet që produkti të kontrollohet për dëmtime nga transporti. Pas instalimit nuk do të njihet asnjë dëmtim nga transporti ose dëmtim i sipërfaqes.
- Tubacionet dhe rubinetet duhet që të montohen, të shpëlahen dhe të kontrollohen sipas standardeve në fuqi
- Duhet të respektohen linjat udhëzuese të instalimit, të vlefshme për vendet respektive.

Të dhëna teknike

Presioni gjatë punës	maks. 1 MPa
Presioni i rekomanduar:	0,1 - 0,5 MPa
Presioni për provë:	1,6 MPa
(1 MPa = 10 bar = 147 PSI)	
Temperatura e ujit të ngrohtë	maks. 70°C
Temperatura e rekomanduar e ujit të ngrohtë:	65°C
Dezinfektim Termik:	maks. 70°C / 4 min

Produkti është projektuar ekskluzivisht për ujë të pijshëm!

Përshkrimi i simbolit



Mos përdorni silikon që në përbërje ka acid acetik.



Justimi (shih faqen 33)

Rregullimi i kufizimit me ujë të nxehtë. Një kombinim me një bojler ujit nuk është i rekomanduar.



Përmasat (shih faqen 34)



Diagrami i qarkullimit (shih faqen 34)

- ① Curril normal
- ② currila/rrezja sperkatese



Pjesët e servisit (shih faqen 36)

XXX = Kodimi me anë të ngjyrave
000 = krom
800 = optikë çeliku



Përdorimi (shih faqen 34)

- Hansgrohe rekomandon që në mëngjes ose pas periudhave të gjata që gjysmë litri i parë mos të pihet
- Gjatë hapjes së rubinetës/valvulës përmes leves dorezë mund të ketë rrjedhje të shkurtë minimal të ujit në dalje.



Mirëmbajtja (shih faqen 35)

Penguesit e rrjedhjes në drejtim të kundërt duhen kontrolluar rregullisht në bazë të normave DIN EN 1717 konform normave nacionale dhe regjionale (së paku një herë në vit).



Pastrimi (shih faqen 35)



Shenja e kontrollit (shih faqen 36)

Dëmtim	Shkaku	Ndihme
Armatura punon rende	- Kartusha me defekt, me kalk	- Kembeni kartushen
Armatura pikon	- Kartusha me defekt	- Kembeni kartushen
Derdhje e ujit në zonën e daljes	- Unaza O me defekt	- Kembeni unazen O
Dalje e ujit në cilindrin fiksues	- Tubat e lidhjes jo komplet të vidhosur në karkasen baze	- Shtrengojini manualisht tubat e lidhur
	- Unaza O tek tubi lidhet me defekt	- Kembeni unazen O
Temperaturë e ulët e ujit të ngrohtë	- Kufiri i ujit të ngrohtë është regjistruar gabim	- Regjistroni kufirin e ujit të ngrohtë



**⚠️ تنبيهات الأمان**

⚠️ يجب إرتداء قفازات لليد أثناء التركيب لتجنب حدوث أخطار الإنحشار أو الجروح.

⚠️ يجب أن يكون تيار الماء الساخن والماء البارد متعادلين في الضغط.

تعليمات التركيب

- قبل القيام بعملية التركيب، يجب فحص المنتج للتأكد من خلوه من أية تلفيات ناتجة عن النقل. بعد القيام بعملية التركيب، لن يتم الاعتراف بوجود أية تلفيات سطحية أو تلفيات ناتجة عن عملية النقل.
- يجب تركيب وغسيل واختبار التوصيلات وخلطات المياه طبقاً للمعايير السارية.
- يجب مراعاة القواعد الخاصة بالتركيب وأعمال السباكة وفقاً للوائح الخاصة بكل بلد.

المواصفات الفنية

ضغط التشغيل:

ضغط التشغيل الموصى به:

ضغط الاختبار:

(1 ميجاباسكال = 10 بار = PSI 147)

درجة حرارة الماء الساخن:

درجة الحرارة الموصى بها للماء الساخن:

تقييم حراري:

المنتج مخصص فقط لماء الشرب!

الحد الأقصى 1 ميجاباسكال

0,5 - 0,1 ميجاباسكال

1,6 ميجاباسكال

الحد الأقصى 70°C

65°C

الحد الأقصى 70°C / 4 الدقيقة

وصف الرمز

هام! لا تستخدم السليكون الذي يحتوي على أحماض!

**الضبط (راجع صفحة 33)**

ضبط تحديد المياه الدافئة. لا ينصح باستخدام محدد المياه الدافئة مع سخان المياه الوتقي.

**أبعاد (راجع صفحة 34)****رسم للصرف (راجع صفحة 34)**

- ① رشاش عادي
- ② الدش

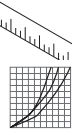
**قطع الغيار (راجع صفحة 36)**

XXX = الألوان

000 = كروم

800 = مظهر الإستنليس ستيل

**التشغيل (راجع صفحة 34)**

- تنصح شركة هانزجر وهي Hansgrohe بعدم استخدام أول نصف لتر من الماء لغرض الشرب وذلك في الصباح أو بعد توقف استخدام الماء لفترات طويلة نسبياً.
- من الممكن تسرب القليل من الماء لفترة قصيرة من مكان تصريف الماء عند فتح الصنبور عن طريق المقبض الرافع.

**الصيانة (راجع صفحة 35)**

يجب فحص صمام عدم الرجوع بصفة منتظمة حسب المواصفة DIN 1717 EN وذلك طبقاً للوائح الوطنية أو الإقليمية (مرة واحد سنوياً على الأقل).

**التنظيف (راجع صفحة 35)****شهادة اختبار (راجع صفحة 36)**

العلاج والإصلاح	السبب	العطل
-قم بتغيير الخرطوشة	-الخرطوشة تالفة، تراكم عليها الجير	الخلاط ثقيل الحركة
-قم بتغيير الخرطوشة	-الخرطوشة تالفة	تساقط قطرات مياه من الخلاط
-قم بتغيير الحلقة الدائرية	-الحلقة الدائرية تالفة	خروج الماء من منطقة الخروج المتأرجح
-اربط خرطوم التوصيل بيدك	-خرطوم التوصيل ليست مربوطة في الجزء الرئيسي بشكل كامل	خروج الماء من جزء التثبيت
-قم بتغيير الحلقة الدائرية	-الحلقة الدائرية الخاصة بخرطوم التوصيل تالفة	
-قم بضبط محدد الماء الساخن	-محدد الماء الساخن مضبوط بشكل خاطيء	درجة حرارة الماء الساخن منخفضة للغاية



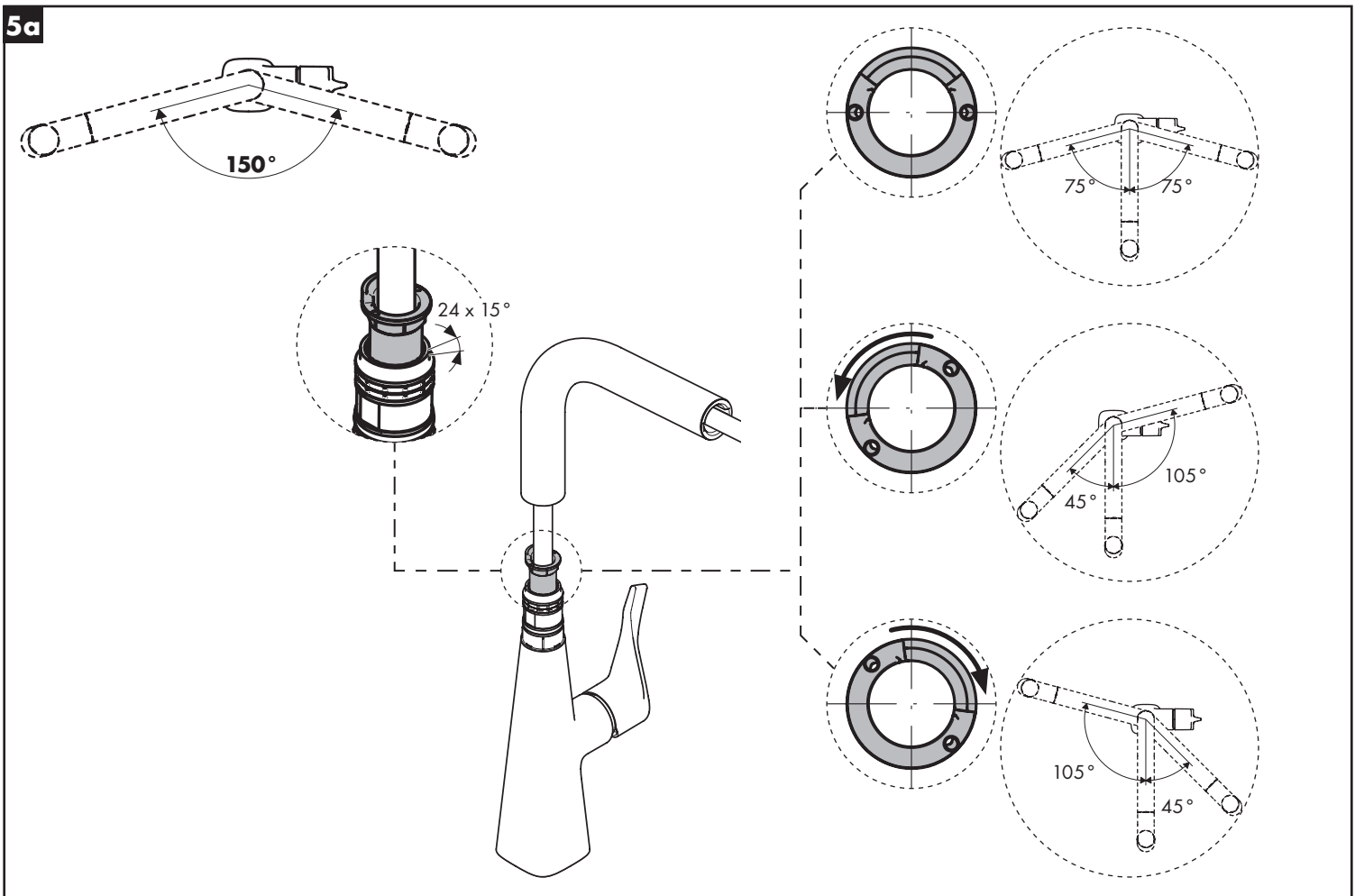
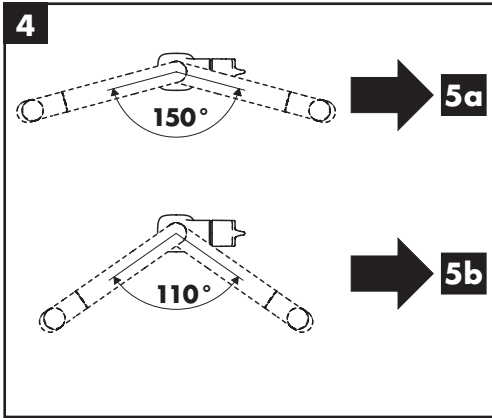
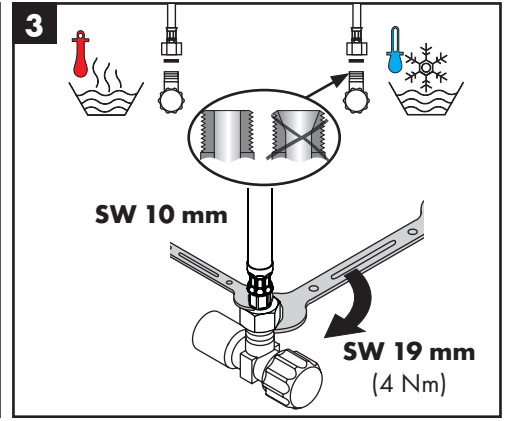
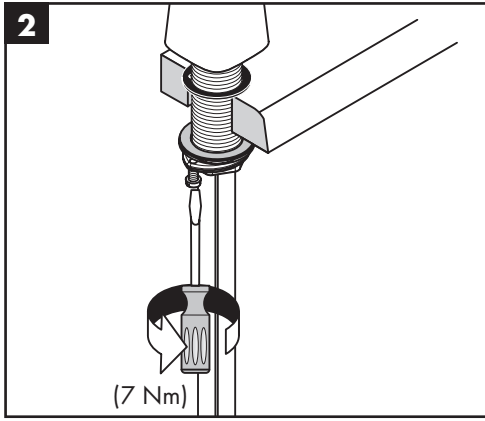
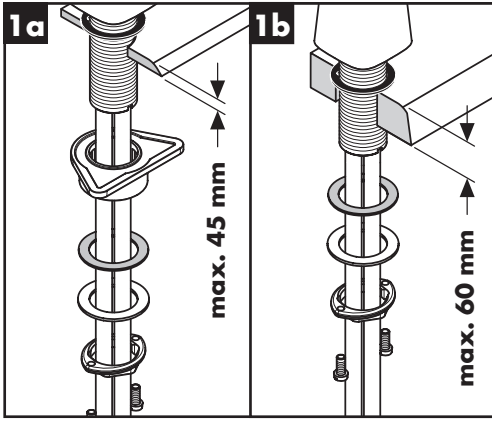



5b

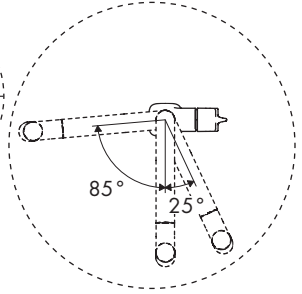
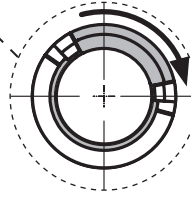
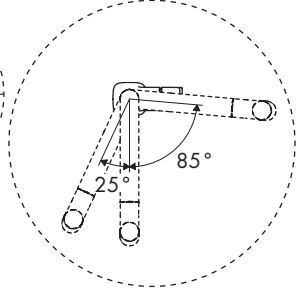
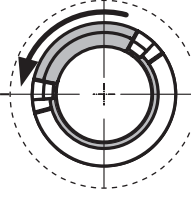
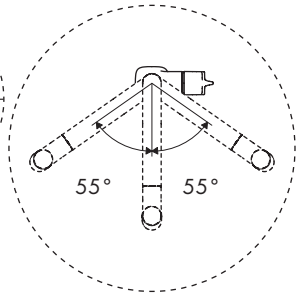
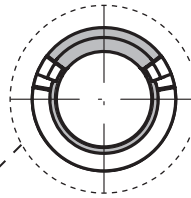
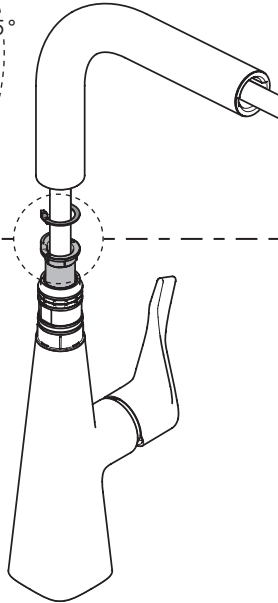
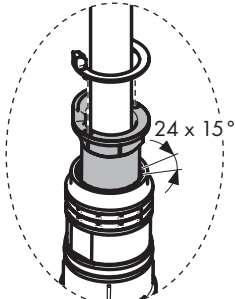
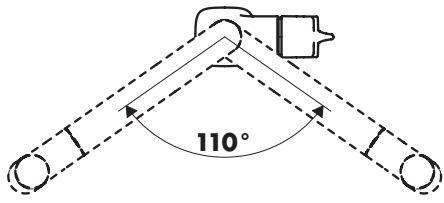

6

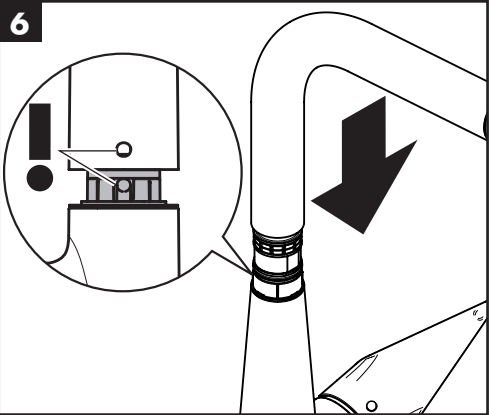

7

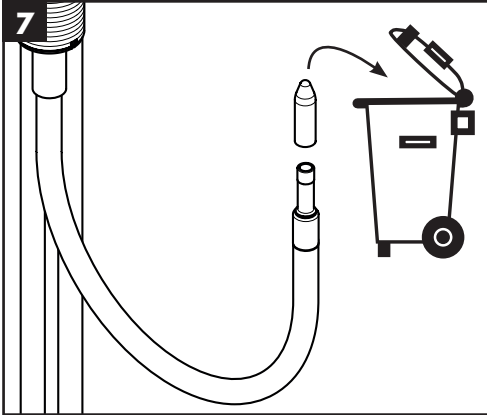

8

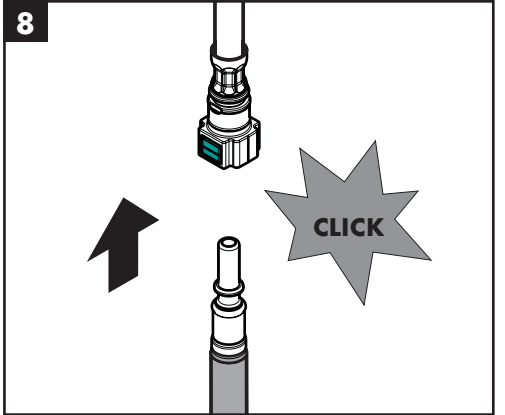

9

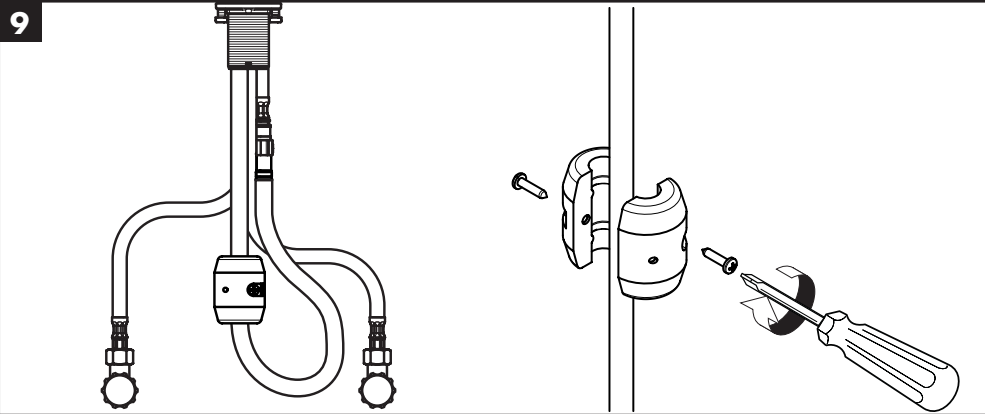

10

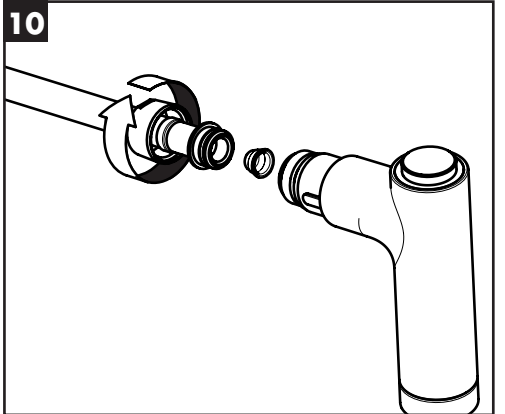

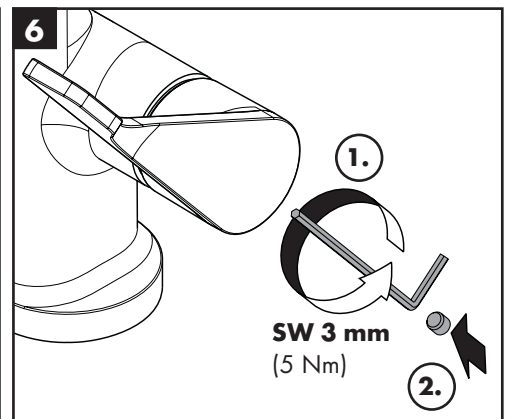
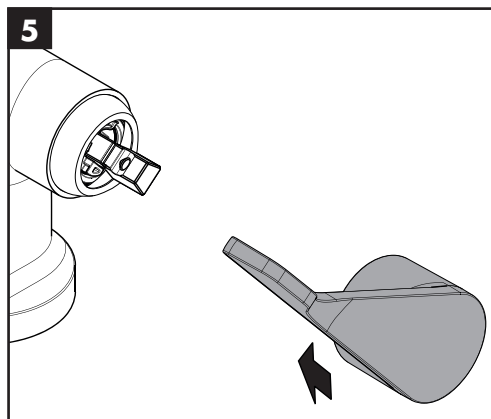
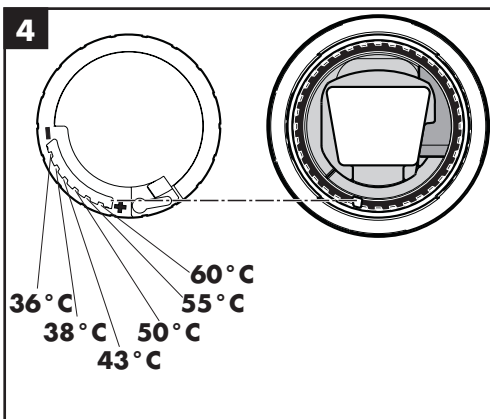
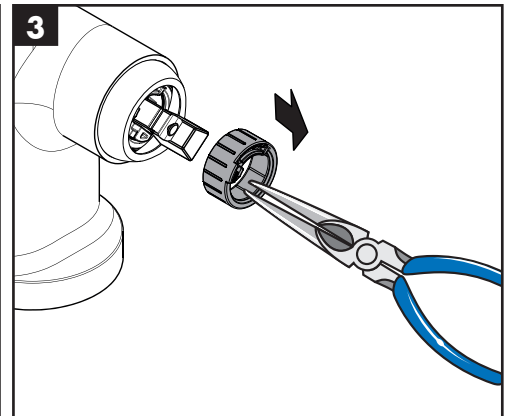
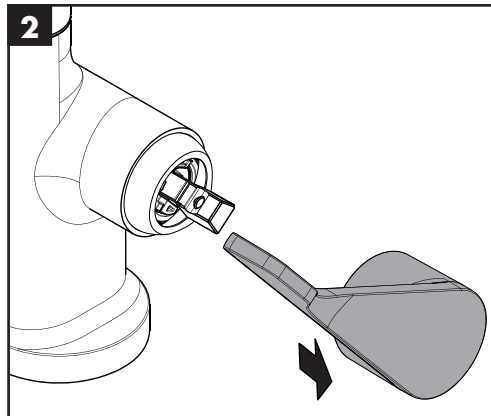
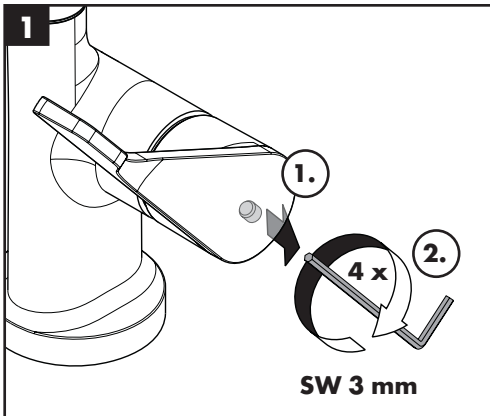
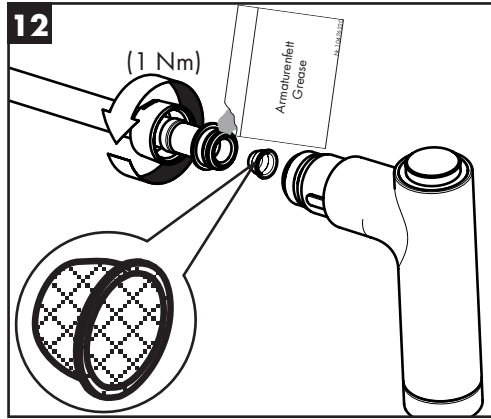
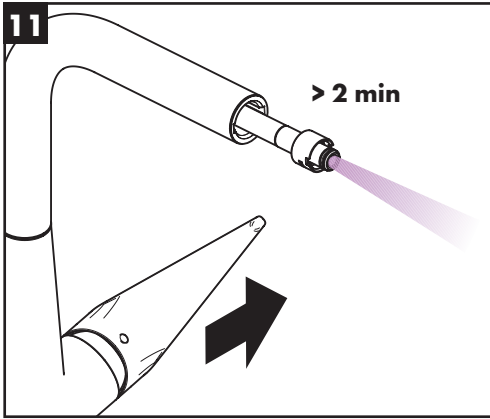

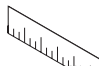

Metris 220
14834000 / 14834800

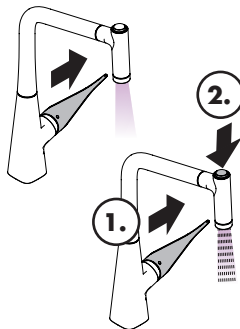
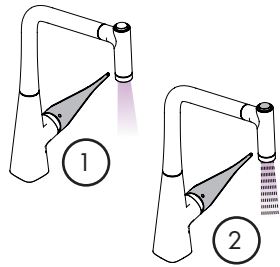
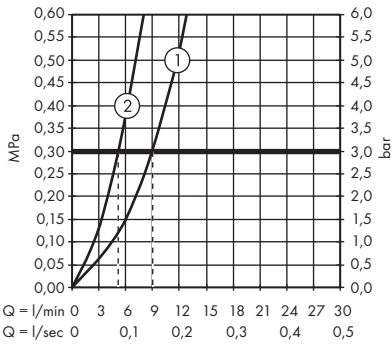
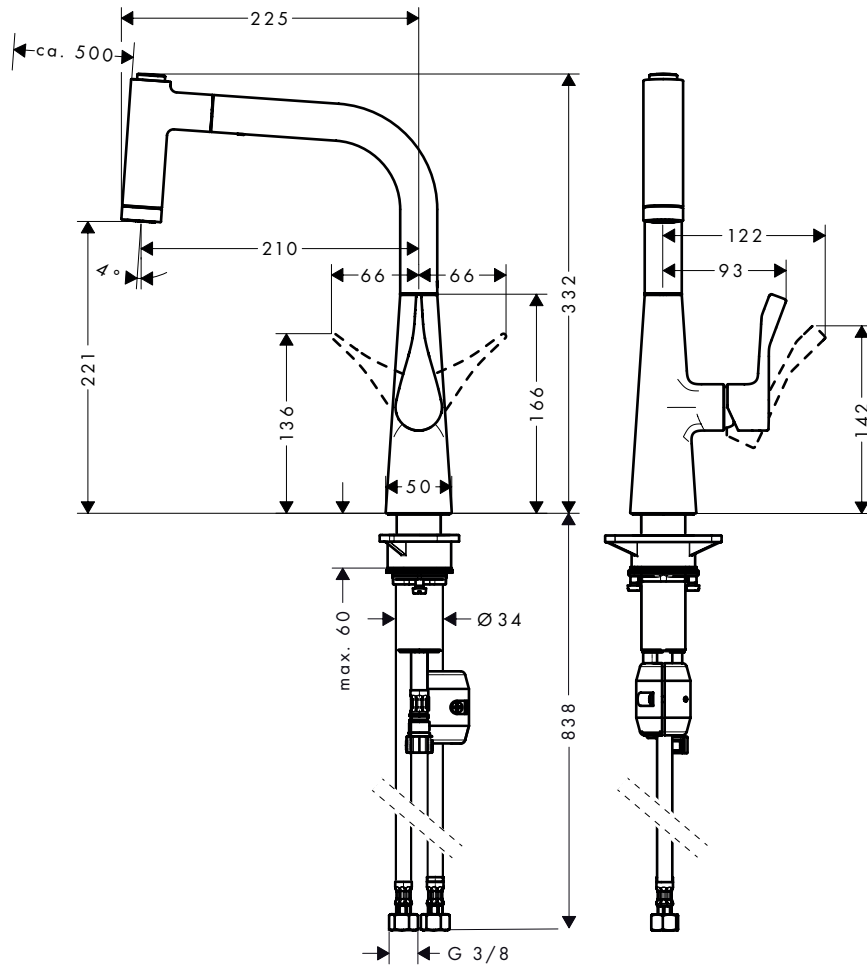

öffnen / ouvert / open / aperto / abierto /
open / åbne / abrir / otworzyć / otevřít / otvorit /
开 / открыть / nyitás / avaaminen / öppna /
atidaryti / Отваранье / açmak / deschide / ανοικτό /
odpreti / avage / atvērt / otvoriti / åpne / отварање /
hape / فتح

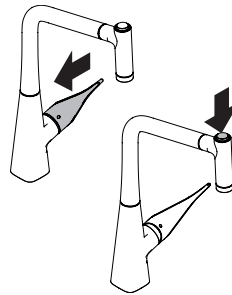

schließen / fermé / close / chiudere / cerrar / sluiten /
lukke / fechar / zamknąć / zavřít / uzavrieť / 关 /
закреть / bezárás / sulkeminen / stänga / uždaryti /
Zatvaranje / kapatmak / închide / κλειστό / zapreti /
sulgege / aizvērt / zatvori / lukke / затваряње /
mbylle / إغلاق

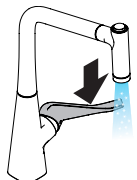

kalt / froid / cold / freddo / frío / koud / koldt / fria /
zimna / studená / studená / 冷 / холодная /
hideg / kylmä / kallt / šaltas / Hladno / soğuk /
rece / κρύο / mrzlo / külm / auksts / hladno / kaldt /
студено / i ftohtë / بارد

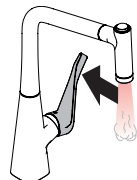

warm / chaud / hot / caldo / caliente / warm /
varmt / quente / ciepła / teplá / teplá / 热 /
горячая / meleg / lämmin / varmt / karštas /
Vruća voda / sıcak / cald / ζεστό / toplo / kuum /
karsts / topla / varm / topno / i ngrohtë / ساخن



www.hansgrohe.com/cleaning-recommendation

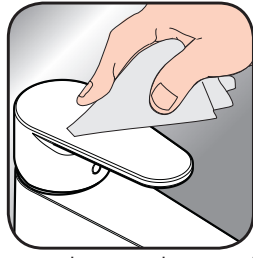

www.hansgrohe.com/cleaning-recommendation



www.hansgrohe.com/cleaning-recommendation



www.hansgrohe.com/cleaning-recommendation

DE Reinigungsempfehlung / Garantie / Kontakt

FR Recommandation pour le nettoyage / Garanties / Contact

EN Cleaning recommendation / Warranty / Contact

IT Raccomandazione di pulizia / Garanzia / Contatto

ES Recomendaciones para la limpieza / Garantía / Contacto

NL Aanbevelingen inzake reiniging / Garantie / Contact

DK Rensning, anbefaling / Garanti / Kontakt

PT Recomendações de limpeza / Garantia / Contacto

PL Zalecenie dotyczące pielęgnacji / Gwarancja / Kontakt

CS Doporučení k čistění / Záruka / Kontakt

SK Odporúčania pre čistenie / Záruka / Kontakt

ZH 清洁指南 / 担保 / 接触

RU Рекомендации по очистке / Гарантия / Контакты

HU Tisztítási tanácsok / Garancia / érintkezés

FI Puhdistussuositus / Takuu / Kosketus

SV Rengöringsrekommendationer / Garanti / Kontakt

LT Valymo rekomendacijos / Garantija / Kontaktai

HR Preporuke za čišćenje / Garancija / Kontakt

TR Temizleme önerisi / Garanti / Temas

RO Recomandări pentru curățare / Garanție / Contact

EL Σύσταση καθαρισμού / Εγγύηση / επαφή

SL Priporočilo za čiščenje / Garancija / Kontakt

ET Puhastussuovitused / Garantii / Kontakt

LV Tīrīšanas ieteikumi / Garantija / Kontakti

SR Preporuke za čišćenje / Garancija / Kontakt

NO Anbefaling for rengjøring / Garanti / Kontakt

BG Препоръка за почистване / Гаранция / Контакт

SQ Këshilla rreth pastrimit / Garancia / Kontakt

KO 세정시 권장사항 / 품질보증 / 접촉

AR توصيات التنظيف / الضمان (الولايات المتحدة الأمريكية) / اتصال

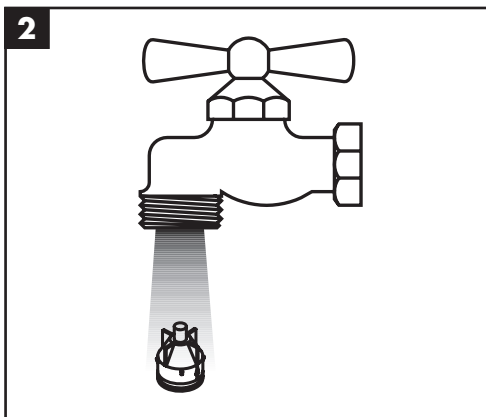
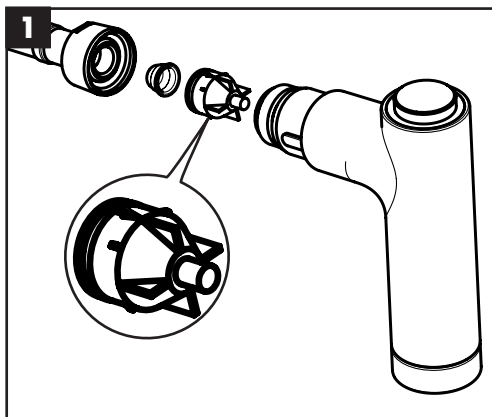
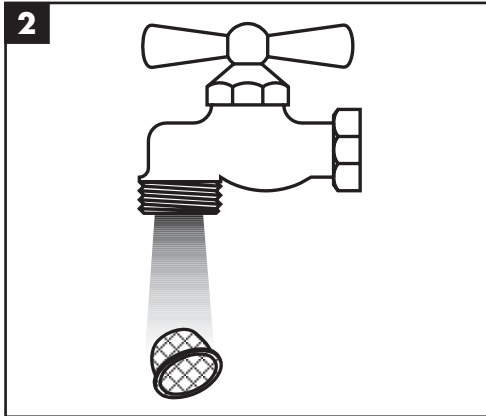
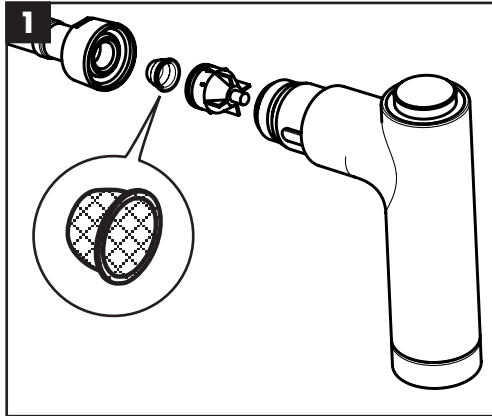

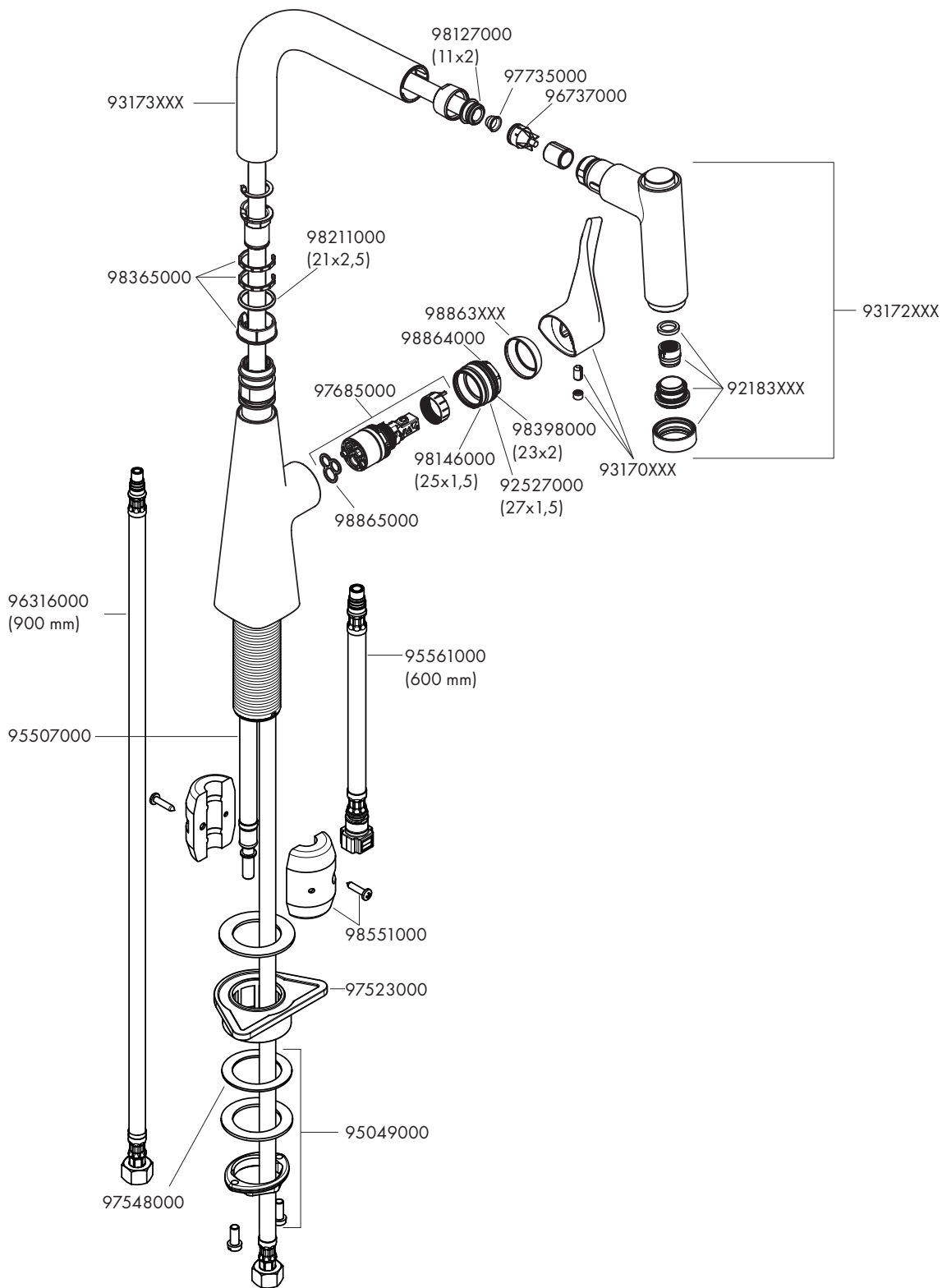

P-IX

DVGW

SVGW

ACS

WRAS



KIWA

14834000 /
14834800

X

hansgrohe

Hansgrohe · AuestraÙe 5 - 9 · D-77761 Schiltach · Telefon +49 (0) 78 36/51-1282 · Telefax +49 (0) 7836/511440
E-Mail: info@hansgrohe.com · Internet: www.hansgrohe.com