

DE	Gebrauchsanleitung / Montageanleitung	2
FR	Mode d'emploi / Instructions de montage	2
EN	Instructions for use / assembly instructions	3
IT	Istruzioni per l'uso / Istruzioni per Installazione	3
ES	Modo de empleo / Instrucciones de montaje	4
NL	Gebruiksaanwijzing / Handleiding	4
DK	Brugsanvisning / Monteringsvejledning	5
PT	Instruções para uso / Manual de Instalação	5
PL	Instrukcja obsługi / Instrukcja montażu	6
CS	Návod k použití / Montážní návod	6
SK	Návod na použitie / Montážny návod	7
ZH	用户手册 / 组装说明	7
RU	Руководство пользователя / Инструкция по монтажу	8
HU	Használati útmutató / Szerelési útmutató	8
FI	Käyttöohje / Asennusohje	9
SV	Brugsanvisning / Monteringsanvisning	9
LT	Vartotojo instrukcija / Montavimo instrukcijos	10
HR	Upute za uporabu / Uputstva za instalaciju	10
TR	Kullanım kılavuzu / Montaj kılavuzu	11
RO	Manual de utilizare / Instrucțiuni de montare	11
EL	Οδηγίες χρήσης / Οδηγία συναρμολόγησης	12
SL	Navodilo za uporabo / Navodila za montažo	12
ET	Kasutusjuhend / Paigaldusjuhend	13
LV	Lietošanas pamācība / Montāžas instrukcija	13
SR	Uputstvo za upotrebu / Uputstvo za montažu	14
NO	Brugsanvisning / Montasjeveiledning	14
BG	Инструкция за употреба / Ръководство за монтаж	15
SQ	Udhëzuesi i përdorimit / Udhëzime rreth montimit	15
AR	دليل الاستخدام / تعليمات التجميع	16

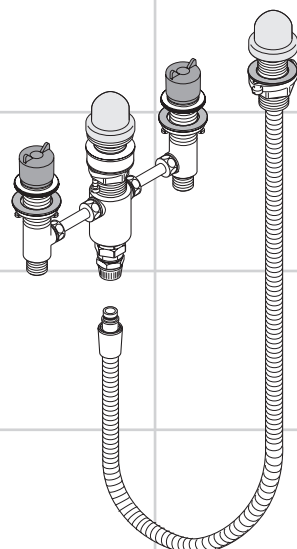

13244180

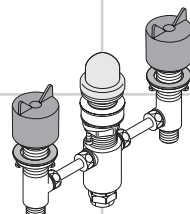

13233180



Sicherheitshinweise

- Bei der Montage müssen zur Vermeidung von Quetsch- und Schnittverletzungen Handschuhe getragen werden.
- Große Druckunterschiede zwischen den Kalt- und Warmwasseranschlüssen müssen ausgeglichen werden.

Montagehinweise

- Vor der Montage muss das Produkt auf Transportschäden untersucht werden. Nach dem Einbau werden keine Transport- oder Oberflächenschäden anerkannt.
- Die Leitungen und die Armatur müssen nach den gültigen Normen montiert, gespült und geprüft werden.
- Die in den Ländern jeweils gültigen Installationsrichtlinien sind einzuhalten.
- Das Wannenrandset muss so eingebaut werden, dass sämtliche Bauteile jederzeit zugänglich sind und bei Bedarf ausgetauscht werden können. Damit durch die Schlauchdurchführung eintretendes Wasser unter der Wanne keine Schäden verursachen kann, muss dieser Bereich gegen Leckwasser geschützt sein.
- Achtung! Es muss einmal jährlich eine Dichtheitsprüfung vorgenommen werden.

Symbolerklärung



Kein essigsäurehaltiges Silikon verwenden!



Maße (siehe Seite 23)



Serviceteile (siehe Seite 24)



Sonderzubehör (nicht im Lieferumfang enthalten)

Secuflex Box #28389000



Prüfzeichen (siehe Seite 24)



Fertigset (siehe Seite 20)

Montage
siehe Seite 17

Consignes de sécurité

- Lors du montage, porter des gants de protection pour éviter toute blessure par écrasement ou coupure.
- Il est conseillé d'équilibrer les pressions de l'eau chaude et froide.

Instructions pour le montage

- Avant son montage, s'assurer que le produit n'a subi aucun dommage pendant le transport. Après le montage, tout dommage de transport ou de surface ne pourra pas être reconnu.
- Les conduites et la robinetterie doivent être montés, rincés et contrôlés selon les normes en vigueur.
- Les directives d'installation en vigueur dans le pays concerné doivent être respectées.
- Le support pour montage sur rebord de baignoire doit être posé de manière à ce que tous les éléments soient accessibles et puissent être échangés en cas de besoin. Pour éviter des dégâts causés par l'infiltration d'eau à travers le support de douche, il faut protéger le périmètre sous la baignoire.
- Attention! Faites une fois une épreuve de la fuite par année.

Description du symbole



Ne pas utiliser de silicone contenant de l'acide acétique!



Dimensions (voir pages 23)



Pièces détachées (voir pages 24)



Accessoires en option (ne fait pas partie de la fourniture)

Secuflex Box #28389000



Classification acoustique et débit (voir pages 24)



Set de finition (voir pages 20)

Montage
voir pages 17





Safety Notes

- △ Gloves should be worn during installation to prevent crushing and cutting injuries.
- △ The hot and cold supplies must be of equal pressures.

Installation Instructions

- Prior to installation, inspect the product for transport damages. After it has been installed, no transport or surface damage will be honoured.
- The pipes and the fixture must be installed, flushed and tested as per the applicable standards.
- The plumbing codes applicable in the respective countries must be observed.
- When installing the bath fitting set, it must be guaranteed, that each part can be within reached and if necessary removed. To avoid damages of entering water by the passage of the hose, the area under the tub must be protected against leaking water.
- Important! Do a leak test once a year.

Symbol description



Do not use silicone containing acetic acid!



Dimensions (see page 23)



Spare parts (see page 24)



Special accessories (order as an extra)

Secuflex Box #28389000



Test certificate (see page 24)



Finish set (see page 20)

**Assembly
see page 17**

Indicazioni sulla sicurezza

- △ Durante il montaggio, per evitare ferite da schiacciamento e da taglio bisogna indossare guanti protettivi.
- △ Attenzione! Compensare le differenze di pressione tra i collegamenti dell'acqua fredda e dell'acqua calda.

Istruzioni per il montaggio

- Prima del montaggio è necessario controllare che non ci siano stati danni durante il trasporto. Una volta eseguito il montaggio, non verranno riconosciuti eventuali danni di trasporto o delle superfici.
- Montare, lavare e controllare tubature e rubinetteria rispettando le norme correnti.
- Vanno rispettate le direttive di installazione nazionali vigenti nel rispettivo paese.
- L'installazione del set bordo vasca deve garantire la possibilità che ogni parte venga facilmente raggiunta e se necessario rimossa. Per evitare danni causati dall'infiltrazione di acqua attraverso il passaggio del tubo, la zona sotto la vasca deve essere protetta.
- Attenzione! Comprovare annualmente l'estanqueidad della rubinetteria.

Descrizione simbolo



Non utilizzare silicone contenente acido acetico!



Ingombri (vedi pagg. 23)



Parti di ricambio (vedi pagg. 24)



Accessori speciali (non contenuto nel volume di fornitura)

Secuflex Box #28389000



Segno di verifica (vedi pagg. 24)



Set esterno (vedi pagg. 20)

**Montaggio
vedi pagg. 17**





⚠ Indicaciones de seguridad

- ⚠ Durante el montaje deben utilizarse guantes para evitar heridas por aplastamiento o corte.
- ⚠ Grandes diferencias de presión en servicio entre agua fría y agua caliente deben equilibrarse.

Indicaciones para el montaje

- Antes del montaje se debe examinarse el producto contra daños de transporte. Después de la instalación so se reconoce ningún daño de transporte o de superficie.
- Los conductos y la grifería deben montarse, lavarse y comprobarse según las normas vigentes.
- Es obligatorio el cumplimiento de las directrices de instalación vigentes en el país respectivo.
- La parte empotrada de la grifería debe ser instalada de tal forma que todos los componentes son accesibles e intercambiables en cada momento. El área por debajo de la bañera debe ser protegida contra fugas de agua y/o disponer de un sumidero, para que el agua que entra a través del conducto del flexo no pueda causar daños.
- ¡Atención! Comprobar la estanqueidad de la grifería anualmente.

Descripción de símbolos



No utilizar silicona que contiene ácido acético!



Dimensiones (ver página 23)



Repuestos (ver página 24)



Opcional (no incluido en el suministro)

Secuflex Box #28389000



Marca de verificación (ver página 24)



Embellecedor exterior (ver página 20)

⚠ Veiligheidsinstructies

- ⚠ Bij de montage moeten ter voorkoming van knel- en snijwonden handschoenen worden gedragen.
- ⚠ Grote drukverschillen tussen de koud- en warmwater-toevoer dienen vermeden te worden.

Montage-instructies

- Vóór de montage moet het product gecontroleerd worden op transportschade. Na de inbouw wordt geen transport- of oppervlakteschade meer aanvaard.
- De leidingen en armaturen moeten gemonteerd, gespoeeld en gecontroleerd worden volgens de geldige normen.
- De in de overeenkomstige landen geldende installatie-richtlijnen moeten nageleefd worden.
- De badrandmengkraan moet zo worden geplaatst, dat men er achteraf altijd nog bij kan komen en onderdelen indien nodig uit kan wisselen. Om eventuele lekkage te vermijden, welke via de handdouche-doorvoer onder het bad zou kunnen ontstaan, dient de ruimte ruimte onder het bad beschermd te zijn tegen lekwater.
- Attention! Eénmaal per jaar moet men deze ruimte op dichtheid testen.

Symboolbeschrijving



Gebruik geen zuurhoudende silicone!



Maten (zie blz. 23)



Service onderdelen (zie blz. 24)



Toebehoren (behoort niet tot het leveringspakket)

Secuflex Box #28389000



Keurmerk (zie blz. 24)



Kleurset (zie blz. 20)



**Montage
zie blz. 17**

**Montaje
ver página 17**



Sikkerhedsanvisninger

- △ Ved monteringen skal der bruges handsker for at undgå kvæstelser og snitsår.
- △ Større trykforskelte mellem koldt og varmt vand bør udjævnes.

Monteringsanvisninger

- Før monteringen skal produktet kontrolleres for transportskader. Efter monteringen godkendes transportskader eller skader på overfladen ikke længere.
- Ledningerne og armaturerne skal monteres, skylles og kontrolleres iht. de gældende standarder.
- Installationsbestemmelserne, der gælder i det enkelte land, skal overholdes.
- Indbygningsarmaturet til karrand skal installeres således, at samtlige indbygningsdele til hver en tid er tilgængelige og ved behov kan udskiftes. Slange gennemføringen skal sikres, således at der ikke kan trænge vand ind under karret.
- Advarsel! Der bør årligt foretages en tæthedsprøve.

Symbolbeskrivelse



Der må ikke benyttes eddikesyreholdig silikone!



Målene (se s. 23)



Reserve dele (se s. 24)



Specialtilbehør (ikke med i leveringsomfang)

Secuflex-boks #28389000



Godkendelse (se s. 24)



Kappesæt (se s. 20)

Montering
se s. 17

Avisos de segurança

- △ Durante a montagem devem ser utilizadas luvas de protecção, de modo a evitar ferimentos resultantes de entalamentos e de cortes.
- △ Grandes diferenças entre as pressões das águas quente e fria devem ser compensadas.

Avisos de montagem

- Antes da montagem deve-se controlar o produto relativamente a danos de transporte. Após a montagem não são aceites quaisquer danos de transporte ou de superfície.
- As tubagens e a torneira têm que ser montadas, enxaguadas e verificadas de acordo com as normas em vigor.
- A prescrições de instalação válidas nos respetivos países devem ser respeitadas.
- Ao instalar o conjunto da misturadora de banheira, deve-se garantir que qualquer dos seus componentes deve ficar acessível e passível de remoção. Para evitar danos provocados pela eventual passagem de água pelo orifício do tubo flexível, o chão debaixo da banheira deve ser impermeabilizado e protegido contra eventuais fugas de água.
- Atenção! Faça um ensaio de fugas uma vez por ano.

Descrição do símbolo



Não utilizar silicone que contenha ácido acético!



Medidas (ver página 23)



Peças de substituição (ver página 24)



Acessórios especiais (não incluído no volume de fornecimento)

Secuflex Box #28389000



Marca de controlo (ver página 24)



Conjunto completo (ver página 20)

Montagem
ver página 17



**⚠ Wskazówki bezpieczeństwa**

- ⚠ Aby uniknąć zranień, takich jak zgniecenia czy przecięcia, podczas montażu należy nosić rękawice.
- ⚠ Znaczne różnice ciśnień na dopływach ciepłej i zimnej wody muszą zostać wyrównane.

Wskazówki montażowe

- Przed montażem należy skontrolować produkt pod kątem szkód transportowych. Po montażu nie widać żadnych szkód transportowych ani szkód na powierzchni.
- Przewody i armatura muszą być montowane, płukane i kontrolowane według obowiązujących norm.
- Należy przestrzegać wytycznych instalacyjnych obowiązujących w danym kraju.
- Zestaw krawędziowy wanny musi być zamontowany w taki sposób, by wszystkie podzespoły były dostępne w każdym czasie i w razie potrzeby można je było wymienić. W celu uniknięcia szkód powodowanych przez wnikającą wodę pod wannę, należy zabezpieczyć przed wodą przeciekową.
- Uwaga! Raz w roku należy podjąć kontrolę szczelności.

Opis symbolu

Nie stosować silikonów zawierających kwas octowy!



Wymiary (patrz strona 23)



Części serwisowe (patrz strona 24)



Wyposażenie specjalne (Nie jest częścią dostawy)

Secuflex Box #28389000



Znak jakości (patrz strona 24)



Elementy zewnętrzne (patrz strona 20)

Montaż

patrz strona 17

⚠ Bezpečnostní pokyny

- ⚠ Pro zabránění řezným zraněním a pohmožděním je nutné při montáži nosit rukavice.
- ⚠ Je nutné vyrovnat velké rozdíly tlaku mezi přípoji studené a teplé vody.

Pokyny k montáži

- Před montáží je třeba produkt zkontrolovat, zda nebyl při transportu poškozen. Po zabudování nebudou uznány žádné škody způsobené transportem nebo poškození povrchu.
- Vedení a armatura musí být namontovány, propláchnuty a otestovány podle platných norem.
- Je třeba dodržovat montážní pravidla platné v dané zemi.
- Sada okrajů vany musí být namontována tak, aby byl možný vždy přístup ke všem dílům a tyto mohly být dle potřeby vyměněny. Aby voda přiváděná hadicovým provedením nemohla pod vanou způsobit žádnou škodu, je třeba tento prostor zajistit proti prosakující vodě.
- Pozor! Je třeba jednou ročně provést zkoušku těsnosti.

Popis symbolů

Nepoužívat silikon s obsahem kyseliny octové!



Rozměry (viz strana 23)



Servisní díly (viz strana 24)



Zvláštní příslušenství (není součástí dodávky)

Secuflex Box #28389000



Zkušební značka (viz strana 24)



Vrchní sada (viz strana 20)

Montáž

viz strona 17





⚠ Bezpečnostné pokyny

- ⚠ Pri montáži musíte nosiť rukavice, aby ste predišli pomliaždeninám a rezným poraneniam.
- ⚠ Veľké rozdiely v tlaku medzi prípojkami studenej a teplej vody musia byť vyrovnané.

Pokyny pre montáž

- Pred montážou musíte produkt skontrolovať, či nebol počas transportu poškodený. Po zabudovaní nebudú uznané žiadne škody spôsobené transportom alebo poškodenia povrchu.
- Ledningarna och blandaren måste monteras, spolás igenom och kontrolleras enligt de gällande normerna.
- Je potrebné dodržiavať smernice o inštalácii, ktoré sú práve teraz platné v krajinách.
- Sada okrajov vane musí byť namontovaná tak, aby bol vždy možný prístup ku všetkým dielom, a aby sa tieto dali vždy podľa potreby vymeniť. Aby voda privádzaná hadicovým prevedením nemohla pod vaňou spôsobiť žiadne škody, je potrebné tento priestor zaistiť
- Pozor! Raz ročne je potrebné vykonať skúšku tesnosti.

⚠ 安全技巧

- ⚠ 装配时为避免挤压和切割受伤，必须戴上手套。
- ⚠ 冷热水管间过大的压力差必须予以平衡。

安装提示

- 安装前必须检查产品是否受到运输损害。安装后将不认可运输损害或表面损伤。
- 管道和阀门必须根据通用标准进行安装、冲洗和检查。
- 请遵守当地国家现行的安装规定。
- 所安装的面盆龙头必须使得所有构件随时可接触到并且在需要时可以进行更换。为确保穿透软管套管的水不会造成损失，必须防止该区域漏水。
- 注意！每年必须进行一次密封性检查。

Popis symbolov

 Nepoužívať silikón s obsahom kyseliny octovej!

 **Rozmery** (viď strana 23)

 **Servisné diely** (viď strana 24)

 **Zvláštne príslušenstvo** (nie je súčasťou dodávky)

Secuflex Box #28389000

符号说明

 请勿使用含有乙酸的硅！

 大小 (参见第 23 页)

 备用零件 (参见第 24 页)

 选装附件 (不在供货范围内)

Secuflex 盒子 #28389000

 检验标记 (参见第 24 页)

 加工件 (参见第 20 页)

 **安装**
参见第 17 页

 **Osvedčenie o skúške** (viď strana 24)

 **Vrchná sada** (viď strana 20)

Montáž
viď strana 17

**⚠ Указания по технике безопасности**

- ⚠ Во время монтажа следует надеть перчатки во избежание прищемления и порезов.
- ⚠ донного клапа. Перед установкой смесителя необходимо регулировочными кранами выровнять авление холодной и горячей воды при помощи вентмлей регулирующих подачу воды в квартиру.

Указания по монтажу

- Перед монтажом следует проверить изделие на предмет повреждений при перевозке. После монтажа претензии о возмещении ущерба за повреждение при перевозке или повреждения поверхностей не принимаются.
- Трубы и арматура должны быть установлены, промыты и проверены в соответствии с действующими нормами.
- Необходимо соблюдать требования по монтажу, действующие в соответствующих странах.
- При установке комплекта для ванн следует обеспечить доступ ко всем комплектующим и возможность их замены по мере необходимости. Во избежание ущерба при попадании воды под ванну в ходе прокладки душевого шланга следует обеспечить защиту этого участка от протечек.
- ВНИМАНИЕ! Один раз в год следует проводить проверку на предмет герметичности.

Описание символов

Не применяйте силикон, содержащий уксусную кислоту.



Размеры (см. стр. 23)



Комплект (см. стр. 24)



Специальные принадлежности (не включено в объем поставки!)
Блок Secuflex #28389000



Знак технического контроля (см. стр. 24)



Наружная часть (см. стр. 20)

Монтаж**см. стр. 17****⚠ Biztonsági utasítások**

- ⚠ A szerelésnél a zúzódások és vágási sérülések elkerülése érdekében kesztyűt kell viselni.
- ⚠ A hidegvíz- és a melegvíz-csatlakozások közötti nagy nyomáskülönbséget kikell egyenlíteni!

Szerelési utasítások

- A szerelés előtt ellenőrizni kell, hogy a terméknek nincs-e szállítási sérülése. Beépítés után a szállítási- vagy felületi sérüléseket nem ismerik el.
- A vezetékeket és a csaptelepet az érvényes szabványoknak megfelelően kell felszerelni, öblíteni és ellenőrizni
- Az egyes országokban érvényes installációs irányelveket be kell tartani.
- A kádperem készletet úgy kell beépíteni, hogy minden alkatrész bármikor elérhető legyen, és szükség esetén ki lehessen cserélni. Azért, hogy a tömlőátvezetésen belépő víz ne okozzon károkat a kád alatt, ezt a területet szivárgó víz ellen védeni kell.
- Figyelem! Évente egyszer szivárgási ellenőrzést kell végezni.

Szimbólumok leírása

Ne használjon ecetsavtartalmú szilikon!



Méretet (lásd a oldalon 23)



Tartozékok (lásd a oldalon 24)



Egyéb tartozék (a szállítási egység nem tartalmazza)

Secuflex Box #28389000



Vizsgajel (lásd a oldalon 24)



A kész szerelvény (lásd a oldalon 20)

Szerelés**lásd a oldalon 17**



⚠ Turvallisuusohjeet

- Asennuksessa on käytettävä käsiineitä puristumien ja viiltojen aiheuttamien tapaturmien estämiseksi.
- Suuret paine-erot kylmä- ja kuumavesiliitäntöjen välillä on tasattava.

Asennusohjeet

- Ennen asennusta on tarkastettava tuotteen mahdolliset kuljetusvahingot. Asennuksen jälkeen kuljetus- ja pintavaurioita ei hyväksytä.
- Putket ja hana on asennettava, huuhdeltava ja tarkastettava voimassa olevien standardien mukaisesti.
- Jokaisessa maassa on noudatettava siellä päteviä asennusohjeita.
- Kylpyammeen reunasetti on asennettava siten, että kaikki rakenneosat ovat vapaasti huollettavissa ja tarvittaessa vaihdettavissa. Jotta lenkun läpiviennistä sisään pääsevä vesi ei aiheuttaisi vahinkoja ammeen alla, alue on suojattava vuotavan veden varalta.
- Huomio! Tiivystarkastus on suoritettava kerran vuodessa.

Merkin kuvaus



Älä käytä etikkahappopitoista silikonia!



Mitat (katso sivu 23)



Varaosat (katso sivu 24)



Erityisvaruste (ei kuulu toimitukseen)

Secuflex Box #28389000



Koestusmerkki (katso sivu 24)



Valmissarja (katso sivu 20)

Asennus
katso sivu 17

⚠ Säkerhetsanvisningar

- Handskar ska bäras under monteringsarbetet så att man kan undvika kläm- och skärskadorgen werden.
- Stora tryckskillnader mellan anslutningarna för varmt och kallt vatten måste utjämnas.

Monteringsanvisningar

- Det måste undersökas om produkten har transportskador innan den monteras. Efter monteringen accepteras inga transport- eller ytskiktsskador.
- Ledningarna och blandaren måste monteras, spolas igenom och kontrolleras enligt de gällande normerna.
- De installationsriktlinjer som gäller i länderna ska följas.
- Sargmonteringsssatsen måste placeras på sådant sätt att alla delar alltid är tillgängliga och kan bytas ut vid behov. Slangnomföringen måste vara tätad så att vatten inte kan ta sig in under karet den här vägen och förorsaka skador.
- OBS! Tätheten måste kontrolleras en gång varje år.

Symbolförklaring



Använd inte silikon som innehåller ättiksyra!



Måtten (se sidan 23)



Reservdelar (se sidan 24)



Specialtillbehör (medföljer ej leveransen)

Secuflex Box #28389000



Testsigill (se sidan 24)



Färdigset (se sidan 20)



Montering
se sidan 17



Saugumo technikos nurodymai

- △ Apsaugai nuo užspaudimo ir įsijovimo montavimo metu mūvėkite pirštines.
- △ Turi būti išlyginti šalto ir karšto slėgio nelygumai.

Montavimo instrukcija

- Prieš montuojant būtina patikrinti, ar gaminyje nebuvo pažeistas transportavimo metu. Sumontavus pretenzijos dėl transportavimo ir paviršiaus pažeidimų nepriimamos.
- Vamzdžiai ir sujungimai turi būti montuojami, plaunami ir tikrinami pagal galiojančias normas.
- Laikykitės atitinkamoje šalyje galiojančių direktyvų dėl įrengimo.
- Vonios kraštai turi būti taip įstatomi, kad bet kurio metu būtų galima prieiti prie bet kurios dalies ir, reikalingi esant, ją pakeisti. Kad žarnomis tekančis vanduo po vonia nepridarytų žalos, šią zoną reikia izoliuoti nuo vandens, prasiskverbiantio pro kiauras vietas.
- Dėmesio! Kartą per metus reikia patikrinti sandarumą.

Sigurnosne upute

- △ Prilikom montaže se radi sprječavanja prignječenja i posjekotina moraju nositi rukavice.
- △ Velika razlika u pritisku između vruće i hladne vode mora biti izbalansirana.

Upute za montažu

- Prije montaže mora se provjeriti je li proizvod oštećen prilikom transporta. Nakon ugradnje se ne priznaju nikakve reklamacije koje se odnose na površinska i transportna oštećenja.
- Cijevi i armatura moraju biti postavljeni, isprani i testirani prema važećim normama.
- Obvezno se moraju uvažiti propisi o instalacijama koji vrijede u dotičnoj zemlji.
- Svi elementi koji se ugrađuju na rubu kade moraju se tako postaviti da budu u svakom trenutku dostupni i po potrebi lako zamjenjivi. Kako voda koja curi sa crijeva tuša ne bi izazvala štetu ispod kade, navedeno se područje mora zaštititi od curenja vode.
- Pažnja! Jednom godišnje se mora provjeriti završljenost.

Simbolio aprašymas



Nenaudokite silikono, kurio sudėtyje yra acto rūgšties!



Išmatavimai (žr. psl. 23)



Atsarginės dalys (žr. psl. 24)



Specialūs priedai (nėra pridama)

„Secuflex“ dėžutė #28389000



Bandymo pažyma (žr. psl. 24)



Virštinkinė (žr. psl. 20)

Opis simbola



Nemojte koristiti silikon koji sadrži octenu kiselinu!



Mjere (pogledaj stranicu 23)



Rezervni djelovi (pogledaj stranicu 24)



Posebni pribor (Nije sadržano u isporuci!)

Secuflex Box #28389000



Oznaka testiranja (pogledaj stranicu 24)



Završni set (pogledaj stranicu 20)

Montavimas
žr. psl. 17



Sastavljanje
pogledaj stranicu 17



⚠️ Güvenlik uyarıları

- ⚠️ Montaj esnasında ezilme ve kesilme gibi yaralanmaları önlemek için eldiven kullanılmalıdır.
- ⚠️ Sıcak ve soğuk su bağlantıları arasında büyük basınç farklılıkları varsa, bu basınç farklılıklarının dengelenmesi gerekir.

Montaj açıklamaları

- Montaj işleminden önce ürün nakliye hasarları yönünden kontrol edilmelidir. Montaj işleminden sonra nakliye veya yüzey hasarları için sorumluluk üstlenilmemektedir.
- Boruların ve armatürün montajı, yıkanması ve kontrolü geçerli normlara göre yapılmalıdır.
- Ülkelerde geçerli kurulum yönetmeliklerine riayet edilmelidir.
- Tekne kenarı seti, tüm yapı parçaları her zaman ulaşılabilir olacak ve gerektiğinde değiştirilebileceği şekilde monte edilmelidir. Hortumun içinden akan suyun teknenin altında herhangi bir hasara yol açmaması için, bu bölge su sızıntısına karşı korunmalıdır.
- Önemli! Yılda bir kez sızdırmazlık testinin yapılması gereklidir.

⚠️ Instrucțiuni de siguranță

- ⚠️ La montare utilizați mănuși pentru evitarea contuziunilor și tăierii mâinilor.
- ⚠️ Diferențele de presiune mari între alimentarea cu apă rece și apă caldă trebuie echilibrate.

Instrucțiuni de montare

- Înainte de instalare verificați, dacă produsul prezintă deteriorări de transport. După instalare garanția nu acoperă deteriorările de transport și cele de suprafață.
- Conductele și bateriile trebuie montate, spălate și verificate conform normelor în vigoare.
- Respectați reglementările referitoare la instalare valabile în țara respectivă.
- Setul de la marginea căzii trebuie montat în așa fel, ca toate elementele construcționale să fie permanent accesibile pentru a putea fi schimbate la nevoie. Pentru ca apa, care se scurge prin garnitura de trecere a furtunului să nu poată cauza deteriorări.
- Atenție! Se va efectua o verificare în privința etanșeității o dată pe an!

Simge açıklaması



Asetik asit içeren silikon kullanmayın!



Ölçüleri (bakınız sayfa 23)



Yedek Parçalar (bakınız sayfa 24)



Özel aksesuarlar (Teslimat kapsamına dahil değildir)

Secuflex Box #28389000



Kontrol işareti (bakınız sayfa 24)



Dışı set (bakınız sayfa 20)

**Montajı
bakınız sayfa 17**

Descrierea simbolurilor



Nu utilizați silicon cu conținut de acid acetic!



Dimensiuni (vezi pag. 23)



Piese de schimb (vezi pag. 24)



Accesorii opționale (nu este inclus în setul livrat)

Boxă secuflex #28389000



Certificat de testare (vezi pag. 24)



Set complet (vezi pag. 20)

**Montare
vezi pag. 17**



**⚠ Υποδειξεις ασφαλείας**

- ⚠ Για να αποφύγετε τραυματισμούς κατά τη συναρμολόγηση πρέπει να φοράτε γάντια.
- ⚠ Οι διαφορές της πίεσης μεταξύ της σύνδεσης κρύου και ζεστού νερού θα πρέπει να αντισταθμίζονται.

Οδηγίες συναρμολόγησης

- Πριν τη συναρμολόγηση πρέπει να εξεταστεί το προϊόν για ζημιές μεταφοράς. Μετά την εγκατάσταση δεν αναγνωρίζονται ζημιές από τη μεταφορά ή επιφανειακές ζημιές.
- Οι σωλήνες και η μπαταρία πρέπει να τοποθετηθούν σύμφωνα με τα ισχύοντα πρότυπα, να τεθούν υπό πίεση και να δοκιμαστούν.
- Θα πρέπει να τηρούνται οι οδηγίες εγκατάστασης που ισχύουν σε κάθε κράτος.
- Το σετ στην άκρη της μπανιέρας πρέπει να εγκαθίσταται έτσι, ώστε όλα τα εξαρτήματα να είναι προσβάσιμα ανά πάσα στιγμή και εφόσον χρειάζεται να μπορούν να αντικαθίστανται. Για να μην μπορεί να προξενήσει ζημιές το νερό που εισέρχεται από το πέρασμα του ελαστικού σωλήνα κάτω από τη μπανιέρα, πρέπει η περιοχή αυτή να προστατευθεί κατάλληλα ώστε να μην σημειωθεί διαρροή.
- Προσοχή! Πρέπει να εκτελείται μία φορά το χρόνο ένας έλεγχος στεγανότητας.

Περιγραφή συμβόλων

Μην χρησιμοποιείτε σιλικόνη που περιέχει οξικό οξύ!



Διαστάσεις (βλ. Σελίδα 23)



Ανταλλακτικά (βλ. Σελίδα 24)



Ειδικά αξεσουάρ (δεν περιλαμβάνεται στον παραδοτέο εξοπλισμό)

Κουτί Secuflex #28389000



Σήμα ελέγχου (βλ. Σελίδα 24)



Σετ μηχανισμού (βλ. Σελίδα 20)

Συναρμολόγηση
βλ. Σελίδα 17

⚠ Varnostna opozorila

- ⚠ Pri montaži je treba nositi rokavice, da se preprečijo poškodbe zaradi zmečkanja ali urezov.
- ⚠ Velike razlike v tlaku med priključkom za mrzlo in priključkom za toplo vodo je potrebno izravnati.

Navodila za montažo

- Pred montažo je treba izdelek preveriti glede morebitnih transportnih poškodb. Po vgradnji transportne ali površinske poškodbe ne bodo več priznane.
- Cevi in armaturo je treba montirati, izprati in preveriti po veljavnih standardih.
- Upoštevati je treba pravilnike o inštalacijah, ki veljajo v posamezni državi.
- Komplet robov za kad se mora vgraditi tako, da so vsi elementi vedno dosegljivi in se lahko po potrebi zamenjajo. Da voda, ki vstopa skozi uvodnico gibke cevi, pod kadjo ne more povzročiti škode, je treba to območje zaščiliti pred iztekaajočo vodo.
- Pozor! Enkrat na leto je treba izvesti preizkus tesnosti.

Opis simbola

Ne smete uporabiti silikona, ki vsebuje ocatno kislino!



Mere (glejte stran 23)



Rezervni deli (glejte stran 24)



Poseben pribor (Ni vključeno)

Secuflex Box #28389000



Preskusni znak (glejte stran 24)





Zaključna garnitura (glejte stran 20)

Montaža
glejte stran 17





Ohutusjuhised

-  Kandke paigaldamisel muljumis- ja löikevigastuste vältimiseks kindaid.
-  Kui külma ja kuuma vee ühenduste surve on väga erinev, tuleb need tasakaalustada.

Paigaldamisjuhised

- Enne paigaldamist tuleb toodet kontrollida transpordikahjustuste osas. Pärast paigaldamist ei tunnustata enam transpordi- või pinnakahjustuste kaebuseid.
- Voolikute ja segisti paigaldamisel, loputamisel ja kontrollimisel tuleb lähtuda kehtivatest normatiividest.
- Vastavas riigis kehtivaid paigalduseeskirju tuleb järgida.
- Vanniäärekomplekt tuleb paigaldada nii, et kõigile selle komponentidele pääseks alati ligi ja neid saaks vajadusel asendada. Et vooliku läbiviigust tulev vesi ei tekitaks vanni alla kahjustusi, tuleb see piirkond lekkiva vee eest kaitsta.
- Tähelepanu! Kord aastas tuleb teha tiheduse kontroll.

Sümbolite kirjeldus

 Ärge kasutage äädikhapet sisaldavat silikooni!

 **Mõõtude** (vt lk 23)

 **Varuosad** (vt lk 24)



 **Spetsiaalne lisavarustus** (ei sisaldu komplektis)
Secuflex-karp #28389000

 **Kontrollsertifikaat** (vt lk 24)

 **Valmiskomplekt** (vt lk 20)

Paigaldamine
vt lk 17

Drošības norādes

-  Montāžas laikā, lai izvairītos no saspiedumiem un iegriezumiem, nepieciešams nēsāt cimdus.
-  Jāizlīdzina spiediena atšķirības starp aukstā un karstā ūdens pievadiem.

Norādījumi montāžai

- Pirms montāžas nepieciešams pārbaudīt, vai produktam transportēšanas laikā nav radušies bojājumi. Pēc iebūvēšanas bojājumi, kas radušies transportēšanas laikā, vai virsmas bojājumi netiek atzīti.
- Caurulvadi un armatūra ir jāuzstāda, jāizskalo un jāpārbauda saskaņā ar spēkā esošajiem standartiem.
- Jāievēro attiecīgās valsts spēkā esošās montāžas prasības.
- Vannas malām jābūt iebūvētām tā, lai visas būvniecības detaļas vienmēr būtu pieejamas un nomaināmas pēc nepieciešamības. Lai caur uzstādīto cauruli ienākošais ūdens zem vannas nevarētu izraisīt nekādus bojājumus, šī vieta ir jāaizsargā no ūdens noplūdes.
- Uzmanību! Reizi gadā ir jāveic blīvējuma pārbaude.

Simbolu nozīme

 Neizmantot silikonu, kas satur etiķskābi!

 **Izmērus** (skat. lpp. 23)

 **Rezerves daļas** (skat. lpp. 24)

 **Speciāli aksesuāri** (komplektā netiek piegādāti)
Secuflex kārba #28389000

 **Pārbaudes zīme** (skat. lpp. 24)

 **Komplekts** (skat. lpp. 20)

Montāža
skat. lpp. 17





Sigurnosne napomene

- Prilikom montaže se radi sprečavanja prignječenja i posekotina moraju nositi rukavice.
- Velika razlika u pritisku između vruće i hladne vode mora biti izbalansirana.

Instrukcije za montažu

- Pre montaže se mora proveriti da li je proizvod oštećen pri transportu. Nakon ugradnje se ne priznaju nikakve reklamacije koje se odnose na površinska i transportna oštećenja.
- Vodovi i armatura moraju biti postavljeni, isprani i testirani prema važećim normama.
- Treba se pridržavati propisa koji u određenim zemljama važe za instalacije.
- Svi elementi koji se ugrađuju na ivici kade moraju se tako postaviti da budu u svakom trenutku dostupni i da se po potrebi mogu zameniti. Da voda koja curi sa creva tuša ne izazove štetu ispod kade, ta oblast mora da se zaštiiti od curenja vode.
- Pažnja! Jednom godišnje se mora proveriti zaptivenost.

Opis simbola



Nemojte koristiti silikon koji sadrži sirćetnu kiselinu!



Mere (vidi stranu 23)



Rezervni delovi (vidi stranu 24)



Poseban pribor (Nije sadržano u isporuci)

Secuflex Box #28389000



Ispitni znak (vidi stranu 24)



Završni set (vidi stranu 20)

Montaža
vidi stranu 17

Sikkerheshenvisninger

- Bruk hansker under montasjen for å unngå klem- og kuttskader.
- Store trykkdifferanser mellom kaldt- og varmtvannstilkoblinger skal utlignes.

Montagehenvisninger

- Før montasjen skal produktet sjekkes for transportskader. Etter monteringen aksepteres ikke noen transport- eller overflateskader.
- Ledningene og armaturen skal monteres, spyles og sjekkes iht. de gyldige normer.
- Gjeldende retningslinjer for rørleggerarbeid i de enkelte land skal følges.
- Settet for karkanten skal bygges inn slik at alle komponenter til enhver tid er lett tilgjengelige og at de kan byttes ut etter behov. Fordi at vannet som lekker gjennom slangegjennomføringer ikke skal forårsake skader under badekaret, skal dette området beskyttes mot lekkasjevann.
- Obs! En gang i året skal det utføres en tetthetskontroll.

Symbolbeskrivelse



Ikke bruk silikon som inneholder eddiksyrel!



Mål (se side 23)



Serviceleder (se side 24)



Ekstratilbehør (ikke med i leveransen)

Secuflex Box #28389000



Prøvemerket (se side 24)



Ferdigsett (se side 20)

Montasje
se side 17





Указания за безопасност

- При монтажа трябва да се носят ръкавици, за да се избегнат наранявания поради притискане или порязване.
- Големите разлики в налягането между изводите за студената и топлата вода трябва да се изравняват.

Указания за монтаж

- Преди монтажа продуктът трябва да се провери за транспортни щети. След монтажа не се признават транспортни или повърхностни щети.
- Тръбопроводите и арматурата трябва да се монтират, промият и проверят в съответствие с валидните норми.
- Трябва да бъдат спазвани валидните в съответните страни предписания за инсталиране.
- Наборът за ръба на ваната трябва да се монтира така, че всички елементи да бъдат достъпни по всяко време и да могат да бъдат сменени при необходимост. За да не се предизвикват повреди под ваната при прекарване на маркучите, тази област трябва да бъде защитена от пропуски на вода.
- Внимание! Веднъж годишно трябва да се проверява херметичността.

Описание на символите

 Не използвайте силикон, съдържащ оцетна киселина!

 **Размери** (вижте стр. 23)

 **Сервизни части** (вижте стр. 24)

 **Специални принадлежности** (не се съдържа в обема на доставката)

Кутия Secuflex #28389000

 **Контролен знак** (вижте стр. 24)

 **Готов набор** (вижте стр. 20)

Монтаж
вижте стр. 17

Udhëzime sigurie

- Пër të evituar lëndimet e pickimeve ose të prerjeve gjatë procesit të montimit duhet që të vishni doreza.
- Ndryshimet e mëdha të presionit mes lidhjeve të ujit të ftohtë dhe atij të ngrohtë duhen ekuilibruar.

Udhëzime për montimin

- Përpara montimit duhet që produkti të kontrollohet për dëmtime nga transporti. Pas instalimit nuk do të njihet asnjë dëmtim nga transporti ose dëmtim i sipërfaqes.
- Tubacionet dhe rubinetet duhet që të montohen, të shpëlahen dhe të kontrollohen sipas standardeve në fuqi
- Duhet të respektohen linjat udhëzuese të instalimit, të vlefshme për vendet respektive.
- Kompleti i buzës së vaskës duhet montuar në atë mënyrë që të gjitha pjesët e ndërrimit të mund të ndërrohen në rast nevoje. Zona nën vaskë duhet të jetë e mbrojtur ndaj ujit me qëllim që një rrjedhje eventuale e ujit nga zorra poshtë vaskës të mos shkaktojë dëme.
- Kujdes! Një herë në vit duhet kontrolluar se a rrjedh uji.

Përshkrimi i simbolit

 Mos përdorni silikon që në përbërje ka acid acetik.

 **Përmasat** (shih faqen 23)

 **Pjesët e servisit** (shih faqen 24)

 **Pajisje të posaçme** (nuk përfshihet në vëllimin e furnizimit)
Kutia Secuflex #28389000

 **Shenja e kontrollit** (shih faqen 24)

 **Komplet i gatshëm** (shih faqen 20)

Montimi
shih faqen 17



⚠️ تنبيهات الأمان

- ⚠️ يجب إرتداء قفازات لليد أثناء التركيب لتجنب حدوث أخطار الإنحشار أو الجروح.
- ⚠️ يجب أن يكون تيار الماء الساخن والماء البارد متعادلين في الضغط.

تعليمات التركيب

- قبل القيام بعملية التركيب، يجب فحص المنتج للتأكد من خلوه من أية تلفيات ناتجة عن النقل. بعد القيام بعملية التركيب، لن يتم الاعتراف بوجود أية تلفيات سطحية أو تلفيات ناتجة عن عملية النقل.
- يجب تركيب وغسيل واختبار التوصيلات وخلطات المياه طبقاً للمعايير السارية.
- يجب مراعاة القواعد الخاصة بالتركيب وأعمال السباكة وفقاً للوائح الخاصة بكل بلد.
- يجب تركيب مجموعة حواف البانيو بطريقة تسمح بالوصول لجميع قطع الغيار في جميع الأوقات حتى يمكن استبدالها إذا لزم الأمر. حتى لا يحدث الماء الداخِل عن طريق فتحة الخرطوم تحت البانيو أية أضرار، يجب حماية هذا النطاق من تسرب الماء.
- تنبيه! يجب عمل إختبار سنوي على جلب منع التسرب.

وصف الرمز

هام! لا تستخدم السليكون الذي يحتوي على أحماض!



أبعاد (راجع صفحة 23)



قطع الغيار (راجع صفحة 24)



ملحقات خاصة (غير مدرج مع المحتويات المسلمة)



صندوق Secuflex #28389000

شهادة اختبار (راجع صفحة 24)



مجموعة كاملة. (راجع صفحة 20)



التركيب

راجع صفحة 17



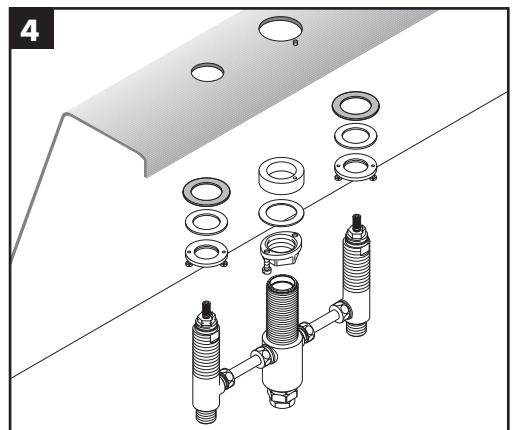
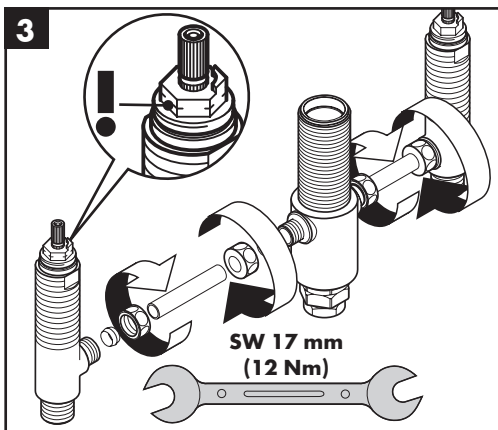
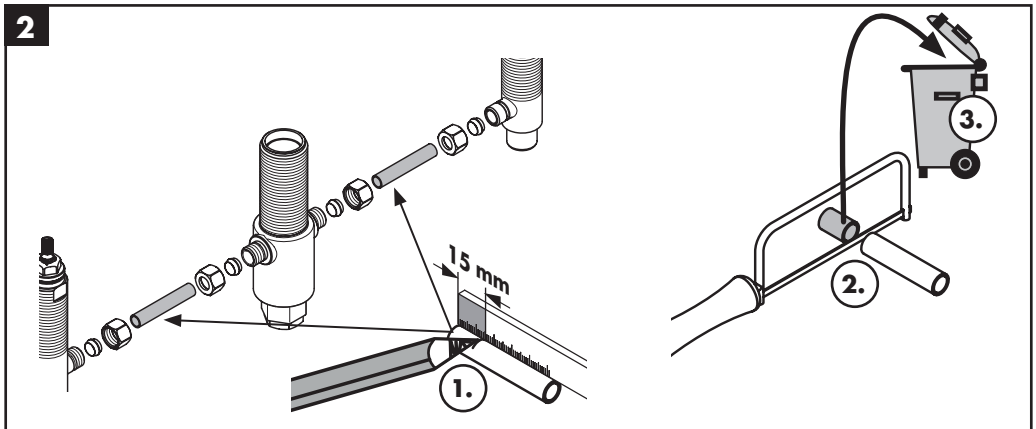
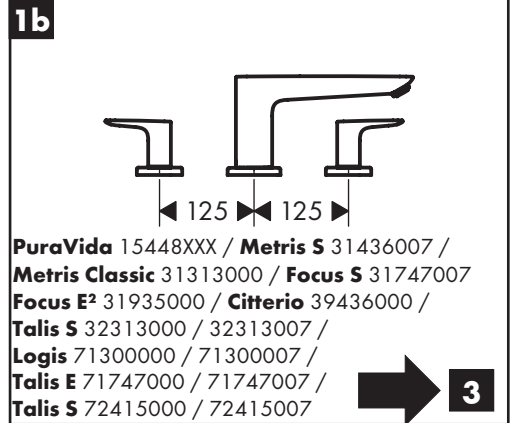
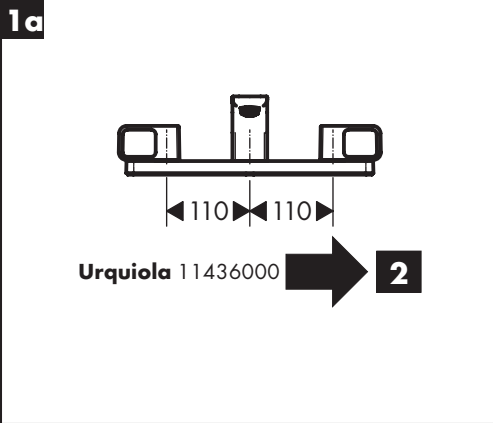

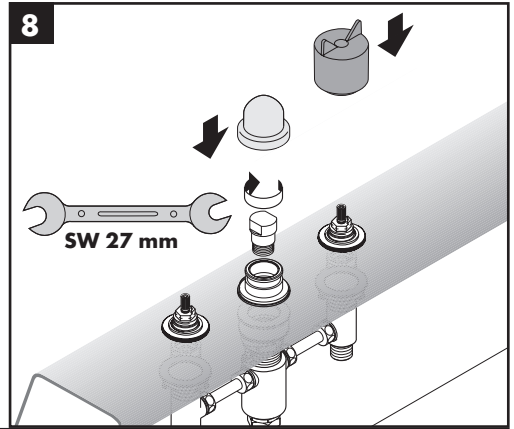
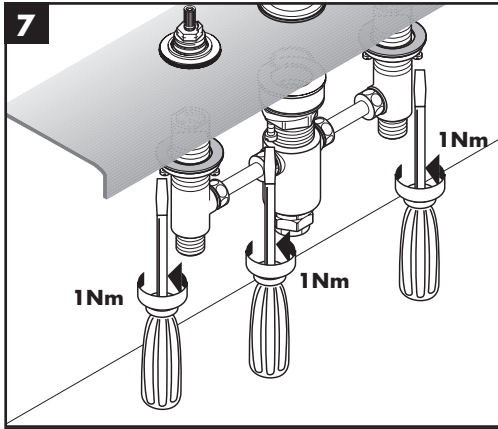
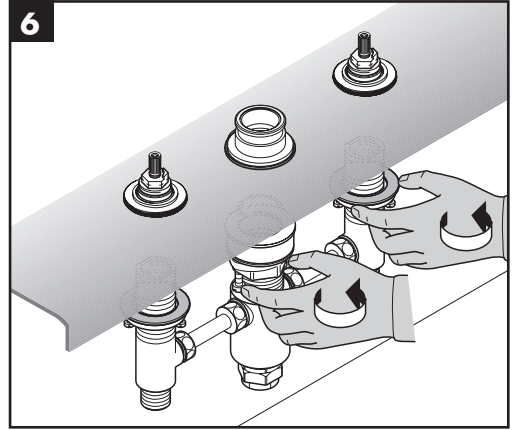
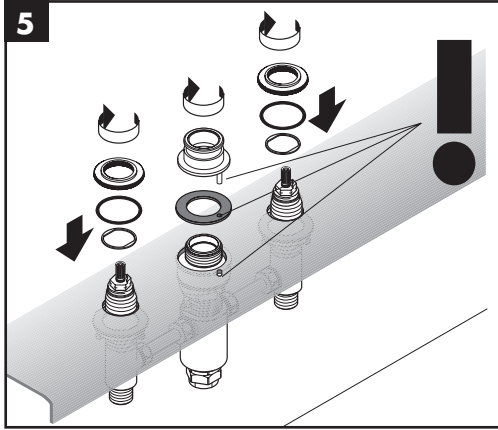

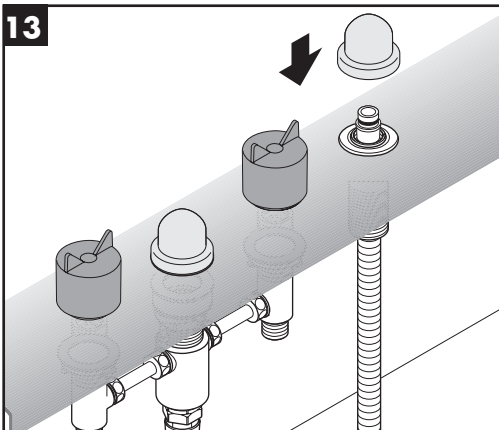
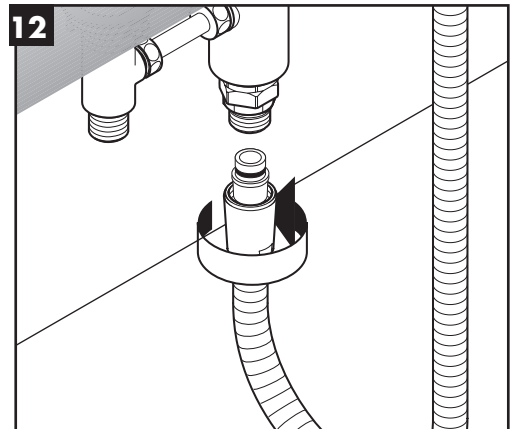
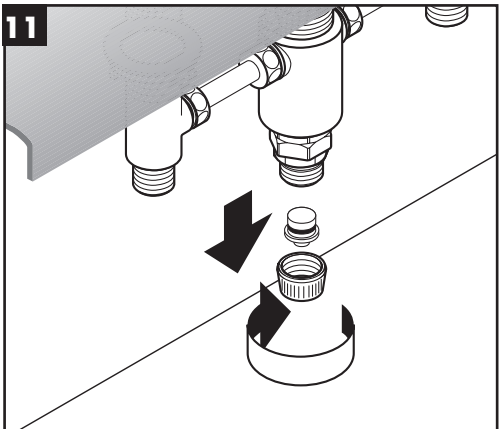
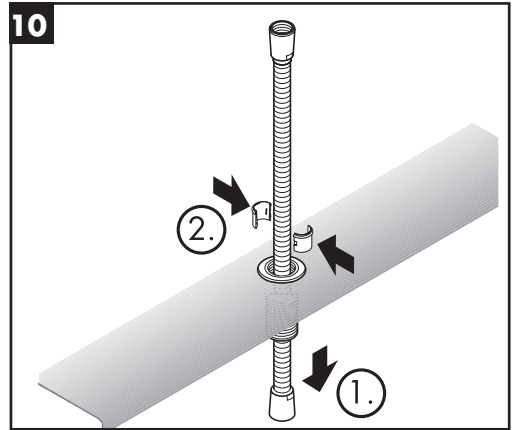
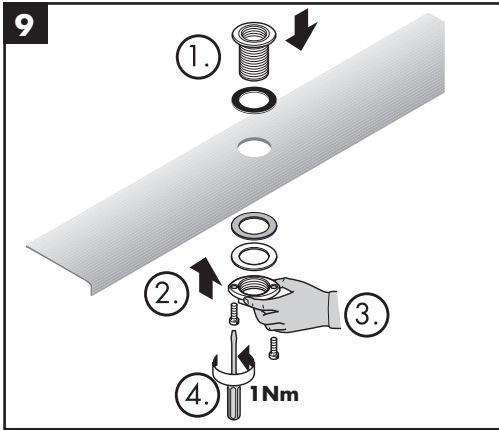



Metris Classic 31314000

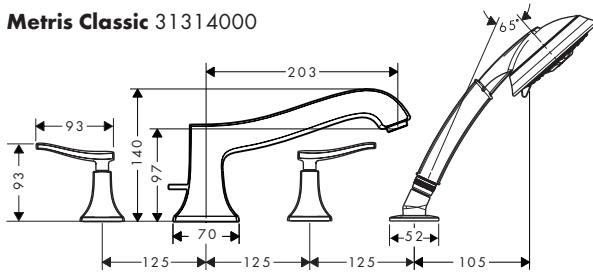

Metris S 31443000 / 31443007

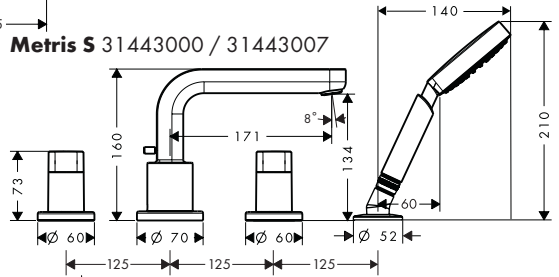

Metris S 31447007

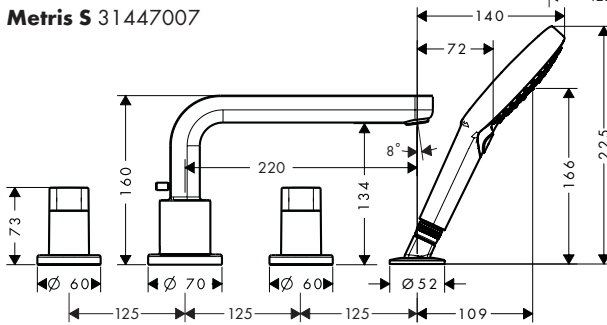

Focus S 31758000 / 31758007

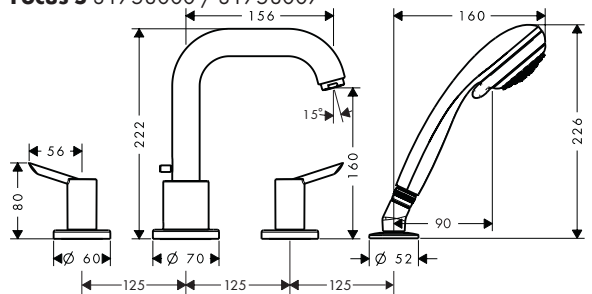

Focus E2 31936000

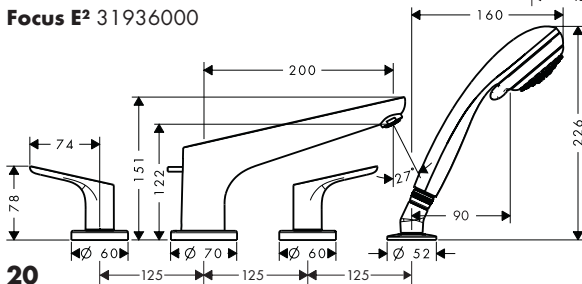



Talis S 32314000 / 32314007

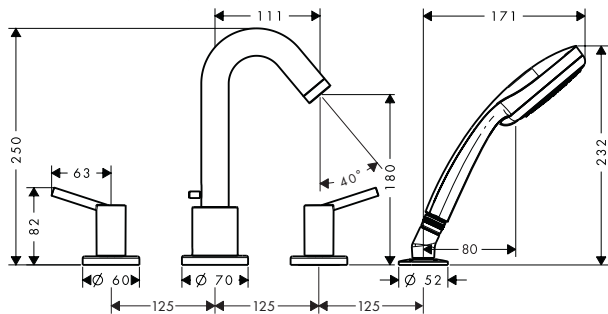

Logis 71314000 / 71314007

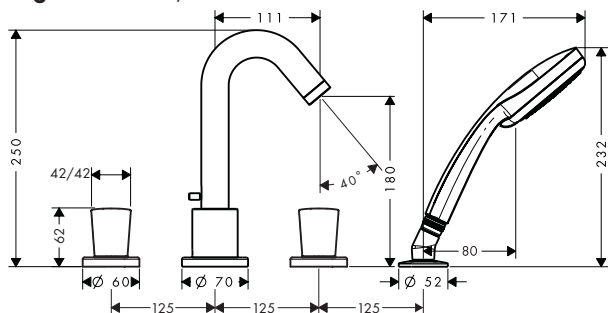

Talis S 72419000 / 72419007

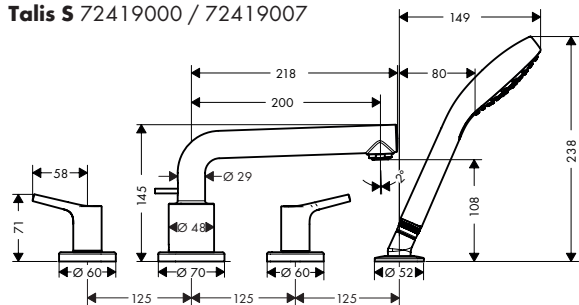

Talis E 71748000 / 71748007

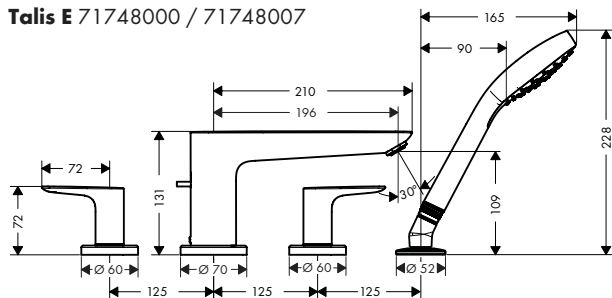



Urquiola 11436000

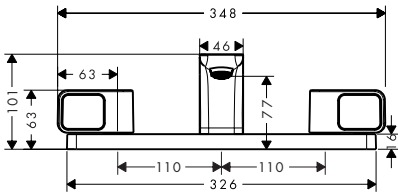

PuraVida 15448XXX

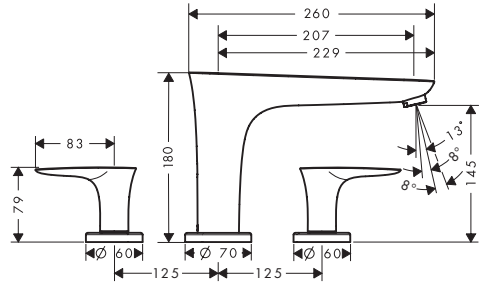

Metris S 31436007

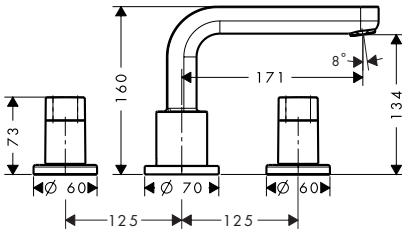

Metris Classic 31313000

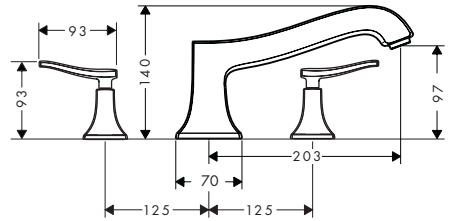

Focus S 31747007

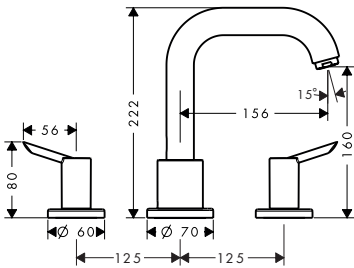

Focus E2 31935000

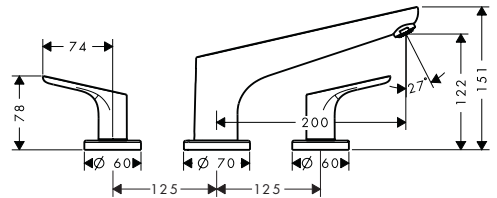

Talis S 32313000 / 32313007

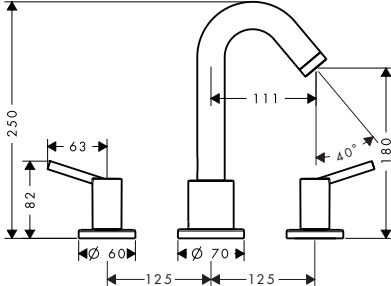

Citterio 39436000

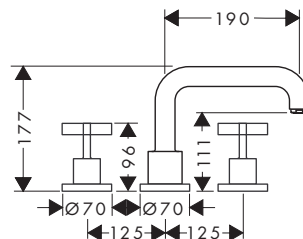



Logis 71300000 / 71300007

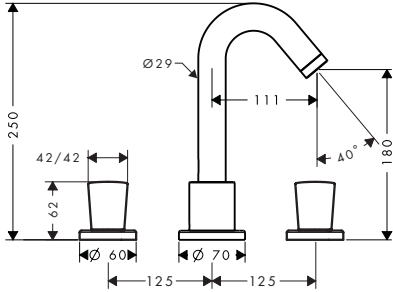

Talis E 71747000 / 71747007

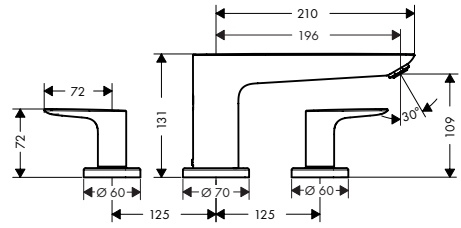

Talis S 72415000 / 72415007

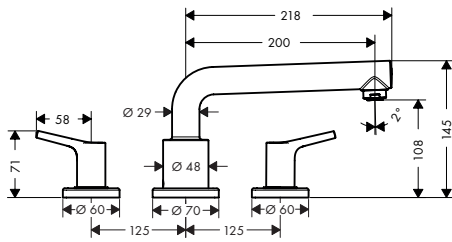

13244180

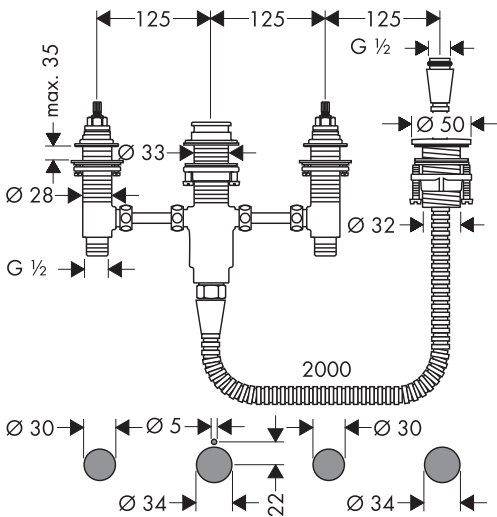

13233180

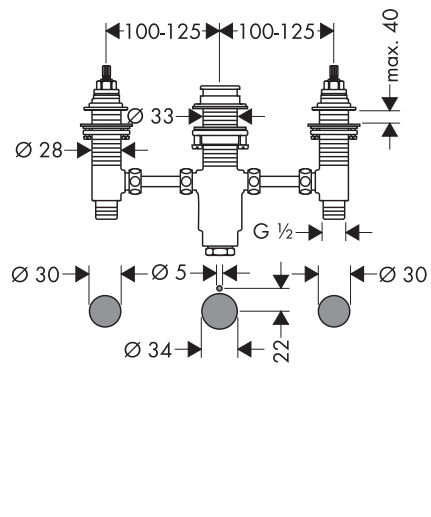

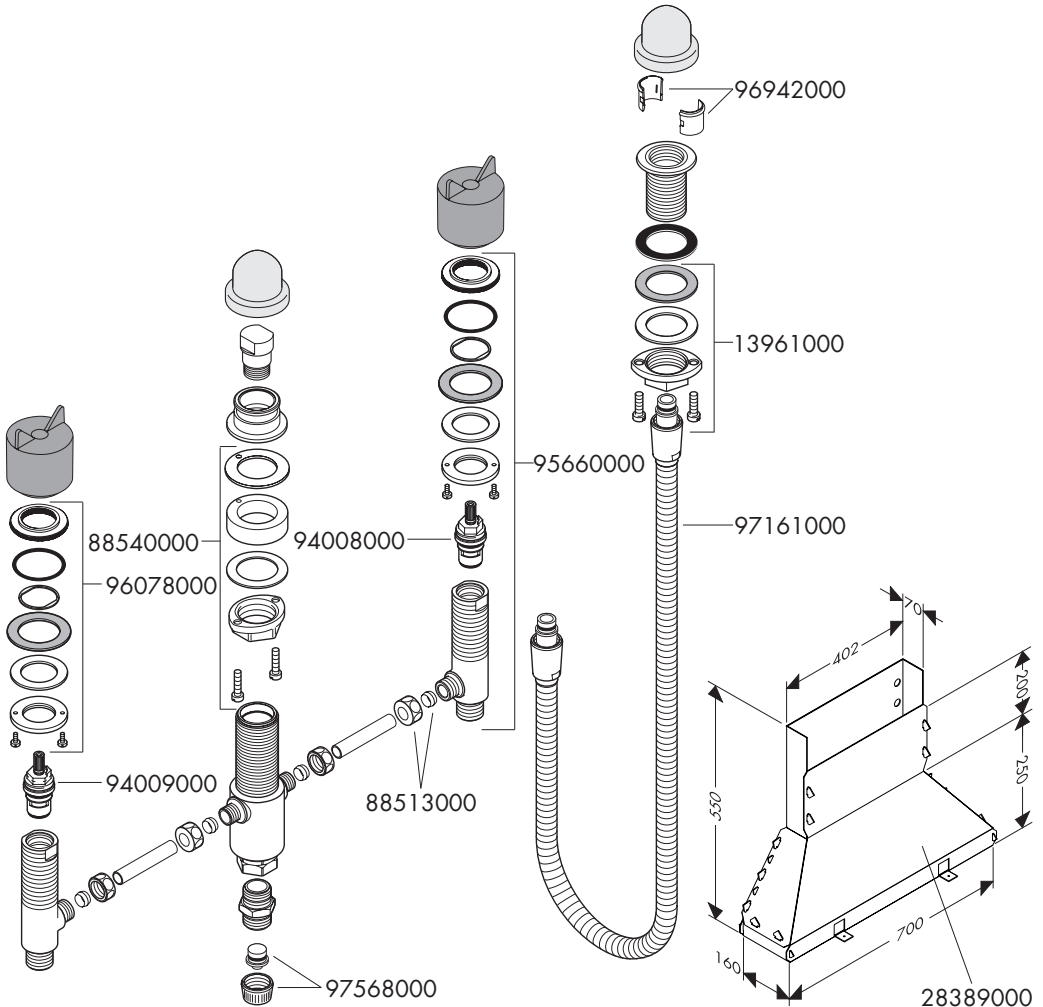

	P-IX	DVGW	SVGW	ACS	WRAS	ETA
13233180				X		1.42/19731
13244180				X	X	