

AXOR

DE / Gebrauchsanleitung / Montageanleitung	02
FR / Mode d'emploi / Instructions de montage	03
EN / Instructions for use / assembly instructions	04
IT / Istruzioni per l'uso / Istruzioni per Installazione	05
ES / Modo de empleo / Instrucciones de montaje	06
NL / Gebruiksaanwijzing / Handleiding	07
DK / Brugsanvisning / Monteringsvejledning	08
PT / Instruções para uso / Manual de Instalação	09
PL / Instrukcja obsługi / Instrukcja montażu	10
CS / Návod k použití / Montážní návod	11
SK / Návod na použitie / Montážny návod	12
ZH / 用户手册 / 组装说明	13
RU / Руководство пользователя / Инструкция по монтажу	14
HU / Használati útmutató / Szerelési útmutató	15
FI / Käyttöohje / Asennusohje	16
SV / Bruksanvisning / Monteringsanvisning	17
LT / Vartotojo instrukcija / Montavimo instrukcijos	18
HR / Upute za uporabu / Uputstva za instalaciju	19
TR / Kullanım kılavuzu / Montaj kılavuzu	20
RO / Manual de utilizare / Instrucțiuni de montare	21
EL / Οδηγίες χρήσης / Οδηγία συναρμολόγησης	22
SL / Navodilo za uporabo / Navodila za montažo	23
ET / Kasutusjuhend / Paigaldusjuhend	24
LV / Lietošanas pamācība / Montāžas instrukcija	25
SR / Uputstvo za upotrebu / Uputstvo za montažu	26
NO / Bruksanvisning / Montasjeveiledning	27
BG / Инструкция за употреба / Ръководство за монтаж	28
SQ / Udhëzuesi i përdorimit / Udhëzime rreth montimit	29
AR / دليل الاستخدام / تعليمات التجميع	30

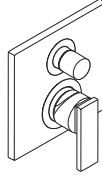

AXOR Citterio
39455000 / 39455003

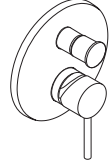

AXOR Starck
10416XXX / 10416003

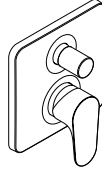

AXOR Citterio M
34425000 / 34425003

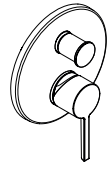

AXOR Starck
10414000

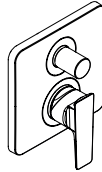

AXOR Citterio E
36455000 / 36455003



AXOR Uno²
38425000

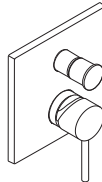

AXOR Starck X
10445000

⚠ SICHERHEITSHINWEISE

- ⚠ Bei der Montage müssen zur Vermeidung von Quetsch- und Schnittverletzungen Handschuhe getragen werden.
- ⚠ Das Produkt darf nur zu Bade-, Hygiene- und Körperreinigungszwecken eingesetzt werden.
- ⚠ Große Druckunterschiede zwischen den Kalt- und Warmwasseranschlüssen müssen ausgeglichen werden.

MONTAGEHINWEISE

- / Vor der Montage muss das Produkt auf Transportschäden untersucht werden. Nach dem Einbau werden keine Transport- oder Oberflächenschäden anerkannt.
- / Die Leitungen und die Armatur müssen nach den gültigen Normen montiert, gespült und geprüft werden.
- / Die in den Ländern jeweils gültigen Installationsrichtlinien sind einzuhalten.

TECHNISCHE DATEN

Betriebsdruck:	max. 1 MPa
Empfohlener Betriebsdruck:	0,1 - 0,5 MPa
Prüfdruck:	1,6 MPa
	(1 MPa = 10 bar = 147 PSI)
Heißwassertemperatur:	max. 70°C
Empfohlene Heißwassertemperatur:	65°C
Thermische Desinfektion:	max. 70°C/4 min

Das Produkt ist ausschließlich für Trinkwasser konzipiert!

SYMBOLERKLÄRUNG



Kein essigsäurehaltiges Silikon verwenden!



JUSTIERUNG (siehe Seite 34)
Einstellen der Warmwasserbegrenzung. In Verbindung mit Durchlauferhitzern ist eine Warmwassersperre nicht zu empfehlen.



MASSE (siehe Seite 31)



DURCHFLUSSDIAGRAMM
(siehe Seite 31)
freier Durchfluss

- ① Abgang Brause
- ② Abgang Wanne



BEDIENUNG (siehe Seite 35)



REINIGUNG (siehe Seite 38)



SERVICETEILE
(siehe Seite 36)
XXX = Farbcodierung
000 = chrom
340 = Brushed Black Chrome
800 = edelstahl-optik



PRÜFZEICHEN (siehe Seite 39)

STÖRUNG	URSACHE	ABHILFE
/ Armatur schwergängig	/ Kartusche defekt, verkalkt	/ Kartusche austauschen
/ Armatur tropft	/ Kartusche defekt	/ Kartusche austauschen
/ Zu niedrige Warmwassertemperatur, kein Kaltwasser. Durchlauferhitzer springt an, wenn Kaltwasser angewählt wird.	/ Warmwasserbegrenzung falsch eingestellt	/ Warmwasserbegrenzung einstellen
	/ Kreuzfluss	/ Kartusche austauschen
/ Umsteller funktioniert nicht	/ Ablagerungen	/ Umsteller reinigen/O-Ringe fetten
	/ Zu geringer Wasserdruck	/ Wasserdruck erhöhen
	/ Umsteller defekt	/ Umsteller austauschen

△ CONSIGNES DE SÉCURITÉ

- △ Lors du montage, porter des gants de protection pour éviter toute blessure par écrasement ou coupure.
- △ Le produit ne doit servir qu'à se laver et à assurer l'hygiène corporelle.
- △ Il est conseillé d'équilibrer les pressions de l'eau chaude et froide.

INSTRUCTIONS POUR LE MONTAGE

- / Avant son montage, s'assurer que le produit n'a subi aucun dommage pendant le transport. Après le montage, tout dommage de transport ou de surface ne pourra pas être reconnu.
- / Les conduites et la robinetterie doivent être montés, rincés et contrôlés selon les normes en vigueur.
- / Les directives d'installation en vigueur dans le pays concerné doivent être respectées.

INFORMATIONS TECHNIQUES

Pression de service autorisée:	max. 1 MPa
Pression de service conseillée:	0,1 - 0,5 MPa
Pression maximum de contrôle:	1,6 MPa (1 MPa = 10 bar = 147 PSI)
Température d'eau chaude:	max. 70°C
Température recommandée:	65°C
Désinfection thermique:	max. 70°C / 4 min

Le produit est exclusivement conçu pour de l'eau potable!

DESCRIPTION DU SYMBOLE



Ne pas utiliser de silicone contenant de l'acide acétique!



ETALONNAGE (voir pages 34)
Réglage de la limitation d'eau chaude. En liaison avec les chauffe-eau, un blocage de l'eau chaude n'est pas recommandable.



DIMENSIONS (voir pages 31)



DIAGRAMME DU DÉBIT
(voir pages 31)
débit libre

- ① Sortie douche
- ② Sortie baignoire



INSTRUCTIONS DE SERVICE
(voir pages 35)



NETTOYAGE (voir pages 38)



PIÈCES DÉTACHÉES
(voir pages 36)
XXX = Couleurs
000 = chromé
340 = Brushed Black Chrome
800 = aspect acier inox



CLASSIFICATION ACOUSTIQUE ET DÉBIT (voir pages 39)

DYSFONCTIONNEMENT	ORIGINE	SOLUTION
/ Dureté de fonctionnement	/ Cartouche défectueuse, entartrée	/ Changer la cartouche
/ Le mitigeur goutte	/ Cartouche défectueuse	/ Changer la cartouche
/ Température d'eau chaude trop basse, pas d'eau froide. Le chauffe eau instantané se met en route quand on puise de l'eau froide.	/ Limiteur de température mal positionné / Flux inversé	/ Positionner le limiteur de température / Changer la cartouche
/ L'inverseur ne fonctionne pas	/ Dépôts / Pression d'alimentation insuffisante / Inverseur défectueux	/ Nettoyer l'inverseur / graisser les joints toriques / Augmenter la pression d'alimentation / Changer l'inverseur

MONTAGE (voir pages 32) 

⚠ SAFETY NOTES

- ⚠ Gloves should be worn during installation to prevent crushing and cutting injuries.
- ⚠ The product may only be used for bathing, hygienic and body cleaning purposes.
- ⚠ The hot and cold supplies must be of equal pressures.

INSTALLATION INSTRUCTIONS

- / Prior to installation, inspect the product for transport damages. After it has been installed, no transport or surface damage will be honoured.
- / The pipes and the fixture must be installed, flushed and tested as per the applicable standards.
- / The plumbing codes applicable in the respective countries must be observed.

TECHNICAL DATA

Operating pressure:	max. 1 MPa
Recommended operating pressure:	0,1 - 0,5 MPa
Test pressure:	1,6 MPa
	(1 MPa = 10 bar = 147 PSI)
Hot water temperature:	max. 70°C
Recommended hot water temp.:	65°C
Thermal disinfection:	max. 70°C / 4 min

The product is exclusively designed for drinking water!

SYMBOL DESCRIPTION



Do not use silicone containing acetic acid!



ADJUSTMENT (see page 34)
To adjust the hot water limiter. Using a hot water limiter in combination with a continuous flow water heater is not recommended.



DIMENSIONS (see page 31)



FLOW DIAGRAM
(see page 31)
free flow

- ① Shower outlet
- ② Tub outlet



OPERATION (see page 35)



CLEANING (see page 38)



SPARE PARTS
(see page 36)
XXX = Colors
000 = chrome plated
340 = Brushed Black Chrome
800 = stainless steel optic



TEST CERTIFICATE (see page 39)

FAULT	CAUSE	REMEDY
/ Mixer stiff	/ Cartridge defective, calcified	/ Exchange cartridge
/ Mixer dripping	/ Cartridge defective	/ Exchange cartridge
/ Hot water temperature too low, no cold water. Instantaneous water heater starts up when cold water is selected.	/ Hot water limiter incorrectly set / Crossflow	/ Set hot water limiter / Exchange cartridge
/ Diverter not operating	/ Residue / Water pressure too low / Diverter defective	/ Clean converter / grease O-rings / Increase water pressure / Exchange diverter

△ INDICAZIONI SULLA SICUREZZA

- △ Durante il montaggio, per evitare ferite da schiacciamento e da taglio bisogna indossare guanti protettivi.
- △ Il prodotto deve essere utilizzato esclusivamente per fare il bagno e per l'igiene del corpo.
- △ Attenzione! Compensare le differenze di pressione tra i collegamenti dell'acqua fredda e dell'acqua calda.

ISTRUZIONI PER IL MONTAGGIO

- / Prima del montaggio è necessario controllare che non ci siano stati danni durante il trasporto. Una volta eseguito il montaggio, non verranno riconosciuti eventuali danni di trasporto o delle superfici.
- / Montare, lavare e controllare tubature e rubinetteria rispettando le norme correnti.
- / Vanno rispettate le direttive di installazione nazionali vigenti nel rispettivo paese.

DATI TECNICI

Pressione d'uso:	max. 1 MPa
Pressione d'uso consigliata:	0,1 - 0,5 MPa
Pressione di prova:	1,6 MPa (1 MPa = 10 bar = 147 PSI)
Temperatura dell'acqua calda:	max. 70°C
Temp. dell'acqua calda consigliata:	65°C
Disinfezione termica:	max. 70°C / 4 min

Il prodotto è concepito esclusivamente per acqua potabile!

DESCRIZIONE SIMBOLO



Non utilizzare silicone contenente acido acetico!



TARATURA (vedi pagg. 34)

Regolazione del limitatore di erogazione d'acqua calda. Un limitatore di erogazione di acqua calda in combinazione con le caldaie istantanee non è consigliabile.



INGOMBRI (vedi pagg. 31)



DIAGRAMMA FLUSSO

(vedi pagg. 31)

portata libero

① uscita doccia

② uscita vasca



PROCEDURA (vedi pagg. 35)



PULITURA (vedi pagg. 38)



PARTI DI RICAMBIO

(vedi pagg. 36)

XXX = Trattamento

000 = cromato

340 = Brushed Black Chrome

800 = acciaio inox acciaio



SEGNO DI VERIFICA

(vedi pagg. 39)

PROBLEMA	POSSIBILE CAUSA	RIMEDIO
/ Miscelatore duro	/ Cartuccia difettosa	/ Sostituire la cartuccia
/ Miscelatore gocciola	/ Cartuccia difettosa	/ Sostituire la cartuccia
/ Temperatura dell'acqua calda troppo bassa, niente acqua fredda, caldaia istantanea si accende quando si seleziona acqua fredda	/ Limitazione dell'acqua calda regolata male / Flusso incrociato	/ Regolare la limitazione dell'acqua calda / Sostituire la cartuccia
/ Deviatore non funziona	/ depositi calcarei / pressione d'acqua troppo bassa / deviatore difettoso	/ pulire il regolatore / ingrassare le guarnizioni O-ring / alzare la pressione d'acqua / sostituire deviatore

△ INDICACIONES DE SEGURIDAD

- △ Durante el montaje deben utilizarse guantes para evitar heridas por aplastamiento o corte.
- △ El producto solo debe ser utilizado para fines de baño, higiene y limpieza corporal.
- △ Grandes diferencias de presión en servicio entre agua fría y agua caliente deben equilibrarse.

INDICACIONES PARA EL MONTAJE

- / Antes del montaje se debe examinarse el producto contra daños de transporte. Después de la instalación no se reconoce ningún daño de transporte o de superficie.
- / Los conductos y la grifería deben montarse, lavarse y comprobarse según las normas vigentes.
- / Es obligatorio el cumplimiento de las directrices de instalación vigentes en el país respectivo.

DATOS TÉCNICOS

Presión en servicio:	max. 1 MPa
Presión recomendada en servicio:	0,1 - 0,5 MPa
Presión de prueba:	1,6 MPa (1 MPa = 10 bar = 147 PSI)
Temperatura del agua caliente:	max. 70°C
Temp. recomendada del agua caliente:	65°C
Desinfección térmica:	max. 70°C / 4 min

El producto ha sido concebido exclusivamente para agua potable.

DESCRIPCIÓN DE SÍMBOLOS



No utilizar silicona que contiene ácido acético



AJUSTE (ver página 34)

Ajuste del límite de agua caliente. En combinación con calentadores continuos no es recomendable utilizar un bloqueo de agua caliente.



DIMENSIONES (ver página 31)



DIAGRAMA DE CIRCULACIÓN

(ver página 31)

caudal libre

① Salida surtidor de ducha

② Salida bañera



MANEJO (ver página 35)



LIMPIAR (ver página 38)



REPUESTOS

(ver página 36)

XXX = Acabados

000 = cromado

340 = Brushed Black Chrome

800 = acero especial



MARCA DE VERIFICACIÓN

(ver página 39)

PROBLEMA	CAUSA	SOLUCIÓN
/ Manecilla va dura	/ cartucho dañado	/ cambiar el cartucho
/ Grifo pierde agua	/ cartucho dañado	/ cambiar el cartucho
/ Temperatura del agua caliente demasiado baja, agua fría calentador se dispara al abrir agua fría	/ tope de agua caliente mal / Flujo cruzado	/ ajustar tope / cambiar el cartucho
/ Inversor no funciona	/ Depósitos / falta presión / inversor defecto	/ Limpiar conmutador de tomas/engrasar anillos tóricos / aumentar presión / cambiar inversor

△ VEILIGHEIDSLINSTRUCTIES

- △ Bij de montage moeten ter voorkoming van knel- en snijwonden handschoenen worden gedragen.
- △ Het product mag alleen voor het wassen, hygiënische doeleinden en voor de lichaamsreiniging worden gebruikt.
- △ Grote drukverschillen tussen de koud- en warmwater-toevoer dienen vermeden te worden.

MONTAGE-INSTRUCTIES

- / Vóór de montage moet het product gecontroleerd worden op transportschade. Na de inbouw wordt geen transport- of oppervlakteschade meer aanvaard.
- / De leidingen en armaturen moeten gemonteerd, gespoeld en gecontroleerd worden volgens de geldige normen.
- / De in de overeenkomstige landen geldende installatie-richtlijnen moeten nageleefd worden.

TECHNISCHE GEGEVENS

Werkdruk: max.	max. 1 MPa
Aanbevolen werkdruk:	0,1 - 0,5 MPa
Getest bij:	1,6 MPa (1 MPa = 10 bar = 147 PSI)
Temperatuur warm water:	max. 70°C
Aanbevolen warm water temp.:	65°C
Thermische desinfectie:	max. 70°C/4 min

Het product is uitsluitend ontworpen voor drinkwater!

SYMBOOLBESCHRIJVING



Gebruik geen zuurhoudende siliconel



INSTELLEN (zie blz. 34)

Instellen van de warmwaterbegrenzing. In combinatie met een doorstromer is een warmwaterblokkering niet aanbevelenswaardig.



MATEN (zie blz. 31)



DOORSTROOMDIAGRAM

(zie blz. 31)

vrije doorstroom

① Uitlaat douche

② Uitlaat bad



BEDIENING (zie blz. 35)



REINIGEN (zie blz. 38)



SERVICE ONDERDELEN

(zie blz. 36)

XXX = Kleuren

000 = verchromd

340 = Brushed Black Chrome

800 = RVS-look



KEURMERK (zie blz. 39)

STORING	OORZAAK	OPLOSSING
/ Bediening zwaar	/ Kardoes defect of verkalkt	/ Kardoes uitwisselen
/ Mengkraan lekt	/ Kardoes defect	/ Kardoes uitwisselen
/ Warmwater temperatuur te laag, geen koud water. Doorstroomtoestel springt aan wanneer koud water gekozen is.	/ Heetwaterbegrenzer verkeerd ingesteld	/ Heetwaterbegrenzer instellen
/ Omstelling functioneert niet	/ Kruisstroom	/ Kardoes uitwisselen
	/ Afzettingen	/ Omsteller reinigen/O-ringen invetten
	/ Waterdruk te laag	/ Waterdruk verhogen
	/ Omstelling defect	/ Omstelling uitwissel

MONTAGE (zie blz. 32) 

△ SIKKERHEDSANVISNINGER

- △ Ved monteringen skal der bruges handsker for at undgå kvæstelser og snitsår.
- △ Produktet må kun bruges til bade-, hygiejne og kroprensengøringsformål.
- △ Større trykforskelle mellem koldt og varmt vand bør undgås.

MONTERINGSANVISNINGER

- / Før monteringen skal produktet kontrolleres for transportskader. Efter monteringen godkendes transportskader eller skader på overfladen ikke længere.
- / Ledningerne og armaturerne skal monteres, skylles og kontrolleres iht. de gældende standarder.
- / Installationsbestemmelserne, der gælder i det enkelte land, skal overholdes.

TEKNISKE DATA

Driftstryk:	max. 1 MPa
Anbefalet driftstryk:	0,1 - 0,5 MPa
Prøvetryk:	1,6 MPa
	(1 MPa = 10 bar = 147 PSI)
Varmtvandstemperatur:	max. 70°C
Anbefalet varmtvandstemperatur:	65°C
Termisk desinfektion:	max. 70°C/4 min

Produktet er udelukkende beregnet til drikkevand!

SYMBOLBESKRIVELSE



Der må ikke benyttes eddikesyreholdig silikone!



FORINDSTILLING (se s. 34)

Indstilling af varmvandsbegrænsningen. I forbindelse med gennemstrømningsvandvarmere anbefaler vi ikke en varmvandsspærre.



MÅLENE (se s. 31)



GENNEMSTRØMNINGSDIAGRAM (se s. 31)

fri gennemstrømning

① Afløb bruser

② Afløb kar



BRUGSANVISNING (se s. 35)



RENGØRING (se s. 38)



RESERVEDELE

(se s. 36)

XXX = Overflade

000 = Krom

340 = Brushed Black Chrome

800 = Stainless steel optic



GODKENDELSE (se s. 39)

FEIL	ÅRSAG	HJÆLP
/ Grebet går trægt	/ Kartusche defekt, tilkalket	/ Udskift kartusche
/ Armaturet drypper	/ Defekt kartusche	/ Udskift kartusche
/ For lav varmtvandstemperatur. Ingen koldt vand. Vandvarmeren starter, når der åbnes for det kolde vand.	/ Varmtvandsbegrænsningen er forkert indstillet	/ Indstil varmtvandsbegrænsningen
/ Omstiller virker ikke	/ Kryds-flow	/ Udskift kartusche
	/ Aflejringer	/ Rens omskifteren/smør O-ringe
	/ For lavt vandtryk	/ Forøg vandtrykket
	/ Defekt omstiller	/ Udskift omstilleren

⚠ AVISOS DE SEGURANÇA

- ⚠ Durante a montagem devem ser utilizadas luvas de protecção, de modo a evitar ferimentos resultantes de entalamentos e de cortes.
- ⚠ O produto só pode ser utilizado para fins de higiene pessoal.
- ⚠ Grandes diferenças entre as pressões das águas quente e fria devem ser compensadas.

AVISOS DE MONTAGEM

- / Antes da montagem deve-se controlar o produto relativamente a danos de transporte. Após a montagem não são aceites quaisquer danos de transporte ou de superfície.
- / As tubagens e a torneira têm que ser montadas, enxaguadas e verificadas de acordo com as normas em vigor.
- / A prescrições de instalação válidas nos respetivos países devem ser respeitadas.

DADOS TÉCNICOS

Pressão de funcionamento:	max. 1 MPa
Pressão de func. recomendada:	0,1 - 0,5 MPa
Pressão testada:	1,6 MPa (1 MPa = 10 bar = 147 PSI)
Temperatura da água quente:	max. 70°C
Temp. água quente recomendada:	65°C
Desinfecção térmica:	max. 70°C/4 min

Este produto foi única e exclusivamente concebido para água potável!

DESCRIÇÃO DO SÍMBOLO



Não utilizar silicone que contenha ácido acético!



AFINAÇÃO (ver página 34)
Ajuste do limitador de água quente. Em combinação com um esquentador, não é recomendável o uso de um bloqueio de água quente.



MEDIDAS (ver página 31)



FLUXOGRAMA
(ver página 31)
caudal livre

- ① Saída do chuveiro
- ② Saída da banheira



FUNCIONAMENTO (ver página 35)



LIMPEZA (ver página 38)



PEÇAS DE SUBSTITUIÇÃO
(ver página 36)
XXX = Acabamentos
000 = cromado
340 = Brushed Black Chrome
800 = aço imaculado ótica



MARCA DE CONTROLO
(ver página 39)

FALHA	CAUSA	SOLUÇÃO
/ Misturadora perra	/ Cartucho defeituoso, calcificado	/ Substituir o cartucho
/ Misturadora a pingar	/ Cartucho defeituoso	/ Substituir o cartucho
/ Temperatura da água quente muito baixa, sem água fria. O esquentador dispara quando a água fria está seleccionada.	/ O limitador de temperatura está incorrectamente colocado	/ Regular o limitador de temperatura
/ Inversor não funciona	/ Fluxo cruzado	/ Substituir o cartucho
	/ Depósitos	/ Limpar inversor/lubrificar vedantes em O
	/ Pressão da água muito baixa	/ Aumentar a pressão da água
	/ Inversor defeituoso	/ Substituir o inversor

⚠ WSKAZÓWKI BEZPIECZEŃSTWA

- ⚠ Aby uniknąć zranień na skutek zgniecenia lub przecięcia, podczas montażu należy nosić rękawice ochronne.
- ⚠ Produkt może być używany tylko do kąpieli, higieny i czyszczenia ciała.
- ⚠ Znaczne różnice ciśnień na dopływach ciepłej i zimnej wody muszą zostać wyrównane.

WSKAZÓWKI MONTAŻOWE

- / Przed montażem należy skontrolować produkt pod kątem szkód transportowych. Po montażu nie widać żadnych szkód transportowych ani szkód na powierzchni.
- / Przewody i armatura muszą być montowane, płukane i kontrolowane według obowiązujących norm.
- / Należy przestrzegać wytycznych instalacyjnych obowiązujących w danym kraju.

DANE TECHNICZNE

Ciśnienie robocze:	maks. 1 MPa
Zalecane ciśnienie robocze:	0,1 - 0,5 MPa
Ciśnienie próbne:	1,6 MPa (1 MPa = 10 bary = 147 PSI)
Temperatura wody gorącej:	maks. 70°C
Zalecana temperatura wody gorącej:	65°C
Dezynfekcja termiczna:	maks. 70°C / 4 min

Produkt przeznaczony wyłącznie do wody pitnej!

OPIS SYMBOLU



Nie stosować silikonów zawierających kwas octowy!



USTAWIANIE (patrz strona 34)
Ustawianie ogranicznika ciepłej wody. Używanie ogranicznika temperatury wody w połączeniu z przepływowym podgrzewaczem wody nie jest zalecane.



WYMIARY (patrz strona 31)



SCHEMAT PRZEPŁYWU
(patrz strona 31)
swobodny przepływ

- ① Odpływ prysznicza
- ② Odpływ wanny



OBSŁUGA (patrz strona 35)



CZYSZCZENIE (patrz strona 38)



CZĘŚCI SERWISOWE
(patrz strona 36)
XXX = Kody kolorów
000 = chrom
340 = Brushed Black Chrome
800 = stal szlachetna



ZNAK JAKOŚCI (patrz strona 39)

USTERKA	PRZYCZYNA	POMOC
/ Uchwyt armatury pracuje z wysiłkiem	/ Uszkodzony wkład, zakamieniony	/ Wymiana wkładu
/ Armatura cieknie	/ Uszkodzony wkład	/ Wymiana wkładu
/ Za niska temperatura ciepłej wody, brak zimnej wody. Przepływowy podgrzewacz wody uruchamia się, gdy wybiera się zimną wodę.	/ Niewłaściwe ustawienie ogranicznik ciepłej wody	/ Ustawić ogranicznik ciepłej wody
/ Przetłacznik nie funkcjonuje	/ Przepływ krzyżowy	/ Wymiana wkładu
	/ Osady	/ Wyczyścić przetłacznik / nasmarować o-ringi
	/ Zbyt niskie ciśnienie wody	/ Podnieść ciśnienie wody
	/ Uszkodzony przetłacznik	/ Wymienić przetłacznik

△ BEZPEČNOSTNÍ POKYNY

- △ Pro zabránění řezným zraněním a pohmožděninám je nutné při montáži nosit rukavice.
- △ Produkt smí být používán pouze ke koupání a za účelem tělesné hygieny.
- △ Je nutné vyrovnat velké rozdíly tlaku mezi přípoji studené a teplé vody.

POKYNY K MONTÁŽI

- / Před montáží je třeba produkt zkontrolovat, zda nebyl při transportu poškozen. Po zabudování nebudou uznány žádné škody způsobené transportem nebo poškození povrchu.
- / Vedení a armatura musí být namontovány, propláchnuty a otestovány podle platných norem.
- / Je třeba dodržovat montážní pravidla platná v dané zemi.

TECHNICKÉ ÚDAJE

Provozní tlak:	max. 1 MPa
Doporučený provozní tlak:	0,1 - 0,5 MPa
Zkušební tlak:	1,6 MPa
	(1 MPa = 10 bar = 147 PSI)
Teplota horké vody:	max. 70°C
Doporučená teplota horké vody:	65°C
Teplná desinfekce:	max. 70°C / 4 min

Výrobky Hansgrohe jsou vhodné pro přímý kontakt s pitnou vodou.

POPIS SYMBOLŮ



Nepoužívat silikon s obsahem kyseliny octové!



NASTAVENÍ (viz strana 34)

Nastavení omezovače teplé vody. Ve spojení s průtokovým ohřívačem se použití uzávěru teplé vody nedoporučuje.



ROZMĚRY (viz strana 31)



DIAGRAM PRŮTOKU

(viz strana 31)

volný průtok

① Odtok sprchy

② Odtok vany



OVLÁDÁNÍ (viz strana 35)



ČIŠTĚNÍ (viz strana 38)



SERVISNÍ DÍLY

(viz strana 36)

XXX = Kód povrchové úpravy

000 = chrom

340 = Brushed Black Chrome

800 = nerezová ocel



ZKUŠEBNÍ ZNAČKA (viz strana 39)

PORUCHA	PŘÍČINA	ODSTRANĚNÍ
/ Armatura jde ztěžka	/ Kartuše je vadná, zanesená vodním kamenem	/ Kartuši vyměnit
/ Armatura odkapává	/ Kartuše je vadná	/ Kartuši vyměnit
/ nízká teplota teplé vody. Žádná studená voda průtokový ohřívač naskočí, když se navolí studená voda	/ Špatně nastavená zarážka pro teplou vodu	/ Seřídít zarážku pro teplou vodu
/ Přepínač nefunguje	/ Křížení toků	/ Kartuši vyměnit
	/ Usazeniny	/ Vyčistit přepínač/promazat o-kroužky
	/ příliš malý tlak vody	/ zvýšit tlak vody
	/ přepínač defektní	/ Přepínač vyměnit

△ BEZPEČNOSTNÉ POKYNY

- △ Pri montáži musíte nosiť rukavice, aby ste predišli pomliaždeninám a rezným poraneniam.
- △ Produkt sa smie používať len na kúpanie a telesnú hygienu.
- △ Veľké rozdiely v tlaku medzi prípojkami studenej a teplej vody musia byť vyrovnané.

POKYNY PRE MONTÁŽ

- / Pred montážou musíte produkt skontrolovať, či nebol počas transportu poškodený. Po zabudovaní nebudú uznané žiadne škody spôsobené transportom alebo poškodenia povrchu.
- / Ledningarna och blandaren måste monteras, spolás igenom och kontrolleras enligt de gällande normerna.
- / Je potrebné dodržiavať smernice o inštalácii, ktoré sú práve teraz platné v krajinách.

TECHNICKÉ ÚDAJE

Prevádzkový tlak:	max. 1 MPa
Doporučený prevádzkový tlak:	0,1 - 0,5 MPa
Skúšobný tlak:	1,6 MPa
	(1 MPa = 10 bar = 147 PSI)
Teplota teplej vody:	max. 70°C
Doporučená teplota teplej vody:	65°C
Termická dezinfekcia:	max. 70°C / 4 min

Výrobok je koncipovaný výhradne pre pitnú vodu!

POPIS SYMBOLOV



Nepoužívať silikón s obsahom kyseliny octovej!



NASTAVENIE (viď strana 34)

Nastavenie obmedzenia teplej vody. V spojení s prietokovými ohrievačmi sa neodporúča použitie obmedzovača teplej vody.



ROZMERY (viď strana 31)



DIAGRAM PRIETOKU

(viď strana 31)

volný prietok

① Odtok sprchy

② Odtok vane



OBSLUHA (viď strana 35)



ČISTENIE (viď strana 38)



SERVISNÉ DIELY

(viď strana 36)

XXX = Farebné označenie

000 = chróm

340 = Brushed Black Chrome

800 = ušľachtilá oceľ



OSVEDČENIE O SKÚŠKE

(viď strana 39)

PORUCHA	PRÍČINA	POMOC
/ Armatúra "chodí" ťažko	/ Kartúša je poškodená, vápenaté usadeniny	/ Vymeniť kartúšu
/ Z armatúry kvapká voda	/ Kartúša je poškodená	/ Vymeniť kartúšu
/ Málo teplá voda, žiadna studená voda, prietokový ohrievač naskočí, keď sa navolí studená voda.	/ Nesprávne nastavená zarážka na teplú vodu	/ Nastavenie zarážky na teplú vodu
/ Prepínač nefunguje	/ Kríženie tokov	/ Vymeniť kartúšu
	/ Usadeniny	/ Vyčistiť prepínač/namazať O krúžky
	/ Príliš malý tlak vody	/ Zvýšiť tlak vody
	/ Prepínač defektný	/ Prepínač vymeniť

△ 安全技巧

- △ 装配时为避免挤压和切割受伤，必须戴上手套。
- △ 本产品只允许作为洗浴、卫生和洁身之用。
- △ 冷热水管间过大的压力差必须予以平衡。

安装提示

- / 安装前必须检查产品是否受到运输损害。安装后将不认可运输损害或表面损伤。
- / 管道和阀门必须根据通用标准进行安装、冲洗和检查。
- / 请遵守当地国家现行的安装规定。

技术参数

工作压强:	最大 1 MPa
推荐工作压强:	0,1 - 0,5 MPa
测试压强:	1,6 MPa
	(1 MPa = 10 bar = 147 PSI)
热水温度:	最大 70°C
推荐热水温度:	65°C
热力消毒:	最大 70°C / 4 分钟

该产品专为饮用水设计！

符号说明



请勿使用含有乙酸的硅胶！



调节 (参见第页 34)

热水温度调节。如果使用即热式喷头，则不建议安装热水阀门。



大小 (参见第页 31)



流量示意图

(参见第页 31)

时的流速

- ① 淋浴出水
- ② 浴缸出水嘴出水



操作 (参见第页 35)



清洗 (参见第页 38)



备用零件

(参见第页 36)

XXX = 颜色代码

000 = 镀铬

340 = Brushed Black Chrome

800 = 不锈钢表面



检验标记 (参见第页 39)

问题	原因	补救
/ 龙头不灵活	/ 阀芯损坏, 结垢	/ 更换阀芯
/ 龙头滴水	/ 阀芯损坏	/ 更换阀芯
/ 热水温度过低, 没有冷水。选择冷水时, 热水器启动。	/ 温度限制器设置错误	/ 设置温度限制器
	/ 交叉流动	/ 更换阀芯
/ 分流器不工作	/ 沉积物	/ 清洁分流器 / 给○形环上油
	/ 水压过低	/ 增加水压
	/ 分流器损坏	/ 更换分流器

安装 (参见第页 32) 

⚠ УКАЗАНИЯ ПО ТЕХНИКЕ БЕЗОПАСНОСТИ

- ⚠ Во время монтажа следует надеть перчатки во избежание прищемления и порезов.
- ⚠ Изделие разрешается использовать только в гигиенических целях: для принятия ванны и личной гигиены.
- ⚠ донного клапа. Перед установкой смесителя необходимо регулировочными кранами выровнять давление холодной и горячей воды при помощи вентилей регулирующих подачу воды в квартиру.

УКАЗАНИЯ ПО МОНТАЖУ

- / Перед монтажом следует проверить изделие на предмет повреждений при перевозке. После монтажа претензии о возмещении ущерба за повреждения при перевозке или повреждения поверхностей не принимаются.
- / Трубы и арматура должны быть установлены, промыты и проверены в соответствии с действующими нормами.
- / Необходимо соблюдать требования по монтажу, действующие в соответствующих странах.

ТЕХНИЧЕСКИЕ ДАННЫЕ

Рабочее давление:	не более. 1 МПа
Рекомендуемое рабочее давление:	0,1 - 0,5 МПа
Давление:	1,6 МПа (1 МПа = 10 bar = 147 PSI)
Температура горячей воды:	не более. 70°C
Рекомендуемая темп. гор. воды:	65°C
Термическая дезинфекция:	не более. 70°C/4 мин

Изделие предназначено исключительно для питьевой воды!

ОПИСАНИЕ СИМВОЛОВ



Не применяйте силикон, содержащий уксусную кислоту.



ПОДГОНКА (см. стр. 34)
Регулировка ограничителя горячей воды. В сочетании с проточными нагревателями не рекомендуется использовать блокировку воды.



РАЗМЕРЫ (см. стр. 31)



СХЕМА ПОТОКА
(см. стр. 31)
свободное истечение

- ① Отвод душа
- ② Отвод ванны



ЭКСПЛУАТАЦИЯ (см. стр. 35)



ОЧИСТКА (см. стр. 38)



КОМПЛЕКТ
(см. стр. 36)

XXX = Цветная кодировка
000 = хром
340 = Brushed Black Chrome
800 = сталь



ЗНАК ТЕХНИЧЕСКОГО КОНТРОЛЯ
(см. стр. 39)

НЕИСПРАВНОСТЬ	ПРИЧИНА	УСТРАНЕНИЕ НЕИСПРАВНОСТИ
/ Арматура работает с усилием	/ Картридж неисправен, засорение накипью	/ Замените картридж
/ Арматура протекает	/ Картридж неисправен	/ Замените картридж
/ Слишком низкая температура горячей воды. Проточный нагреватель запускается при выборе холодной воды.	/ Ограничение горячей воды отрегулировано неправильно / Перекрестный поток	/ Отрегулируйте ограничение горячей воды / Замените картридж
/ Переключатель не работает	/ отложения	/ очистите переключатель / смажьте консистентной смазкой кольца круглого сечения
	/ Слишком малое давление воды	/ Увеличьте давление воды
	/ Переключатель неисправен	/ Замените переключатель



△ BIZTONSÁGI UTASÍTÁSOK

- △ A szerelésnél a zúzódások és vágási sérülések elkerülése érdekében kesztyűt kell viselni.
- △ A terméket csak fürdéshez, mosakodáshoz, és egészségügyi tisztálkodáshoz szabad használni.
- △ A hidegvíz- és melegvíz-csatlakozások közötti nagy nyomáskülönbséget kikell egyenlíteni!

SZERELÉSI UTASÍTÁSOK

- / A szerelés előtt ellenőrizni kell, hogy a terméknek nincs-e szállítási sérülése. Beépítés után a szállítási- vagy felületi sérüléseket nem ismerik el.
- / A vezetékeket és a csaptelepet az érvényes szabványoknak megfelelően kell felszerelni, öblíteni és ellenőrizni
- / Az egyes országokban érvényes installációs irányelveket be kell tartani.

MŰSZAKI ADATOK

Üzemi nyomás:	max. 1 MPa
Ajánlott üzemi nyomás:	0,1 - 0,5 MPa
Nyomáspróba:	1,6 MPa
	(1 MPa = 10 bar = 147 PSI)
Forróvíz hőmérséklet:	max. 70°C
Forróvíz javasolt hőmérséklete:	65°C
Termikus fertőtlenítés:	max. 70°C/4 perc

A terméket kizárólag ivóvízhez tervezték!

SZIMBÓLUMOK LEÍRÁSA



Ne használjon ecetsavtartalmú szilikon!



BEÁLLÍTÁS (lásd a oldalon 34)

A meleg víz korlátozás beállítása. Átfolyós vízmelegítőknél meleg víz korlátozó használata nem ajánlott.



MÉRETET (lásd a oldalon 31)



ÁTFOLYÁSI DIAGRAMM

(lásd a oldalon 31)
szabad átfolyás

- ① Zuhany lefolyója
- ② Kád lefolyója



HASZNÁLAT (lásd a oldalon 35)



TISZTÍTÁS (lásd a oldalon 38)



TARTOZÉKOK

(lásd a oldalon 36)
XXX = Szinkódolás

000 = króm

340 = Brushed Black Chrome

800 = acéloptika



VIZSGAJEL (lásd a oldalon 39)

HIBA	OK	MEGOLDÁS
/ Nehezen nyitható a csap.	/ A kerámiabetét meghibásodott, elvizesedett.	/ A kerámiabetétet ki kell cserélni.
/ Csöpög a csap.	/ A kerámiabetét meghibásodott.	/ A kerámiabetétet ki kell cserélni.
/ Túl alacsony melegvíz hőmérséklet, nincs hidegvíz. A hidegvíz kiválasztásakor beindul az átfolyós melegítő.	/ A melegvíz szabályozó rosszul van beállítva. / Kereszfolyás	/ A melegvíz szabályozót újra be kell állítani. / A kerámiabetétet ki kell cserélni.
/ Az átállítás nem működik	/ Lerakódások / Túl kicsi víznyomás / A kádváltó szelep hibás	/ Váltószelepet tisztítani/O-gyűrűket zsírozni / Növelje a víznyomást / Az átállító cseréje

SZERELÉS (lásd a oldalon 32)



△ TURVALLISUUSOHJEET

- △ Asennuksessa on käytettävä käsineitä puristumien ja viiltojen aiheuttamien tapaturmien estämiseksi.
- △ Tuotetta saa käyttää ainoastaan kylpy-, hygienia- ja puhdistustarkoituksiin.
- △ Suuret paine-erot kylmä- ja kuumavesiliitäntöjen välillä on tasattava.

ASENNUSOHJEET

- / Ennen asennusta on tarkastettava tuotteen mahdolliset kuljetusvahingot. Asennuksen jälkeen kuljetus- ja pintavaurioita ei hyväksytä.
- / Putket ja hana on asennettava, huuhdeltava ja tarkastettava voimassa olevien standardien mukaisesti.
- / Jokaisessa maassa on noudatettava siellä päteviä asennusohjeita.

TEKNISET TIEDOT

Käyttöpain:	maks. 1 MPa
Suosittelun käyttöpain:	0,1 - 0,5 MPa
Koestuspaine:	1,6 MPa (1 MPa = 10 bar = 147 PSI)
Kuuman veden lämpötila:	maks. 70°C
Kuuman veden suosituslämpötila:	65°C
Lämpödesinfektio:	maks. 70°C/4 min

Tuote on suunniteltu käytettäväksi ainoastaan juomaveden kanssa!

MERKIN KUVAUS



Älä käytä etikkahappopitoista silikonial



SÄÄTÖ (katso sivu 34)

Lämpötilan rajoittimen säätäminen. Emme suosittele käyttämään lämpötilan rajoitinta vedenlämmittimen (läpivirtauskuumennin) yhteydessä.



MITAT (katso sivu 31)



VIRTAUSDIAGRAMMI

(katso sivu 31)

vapaa läpivirtaus

① Suihkun lähtö

② Ammeen lähtö



KÄYTTÖ (katso sivu 35)



PUHDISTUS (katso sivu 38)



VARAOSAT

(katso sivu 36)

XXX = Värikoodaus

000 = kromi

340 = Brushed Black Chrome

800 = inox-optinen



KOESTUSMERKKI (katso sivu 39)

HÄIRIÖ

- / Hana on raskaskäyttöinen
- / Hanasta tippuu vettä
- / Lämminveden lämpötila liian alhainen, ei kylmää vettä. Läpivirtauskuumennin käynnistyy kylmää vettä otettaessa.
- / Valitsin ei toimi

SYY

- / Patruuna rikki, kalkkikerrostumia
- / Patruuna rikki
- / Lämminveden rajoitin väärin säädetty
- / Ristiinvirtaus
- / kerrostumia
- / Liian matala vedenpaine
- / Valitsin rikki

TOIMENPIDE

- / Vaihda patruuna
- / Vaihda patruuna
- / Säädi lämminveden rajoitin
- / Vaihda patruuna
- / Vaihtimen puhdistus/○-renkaiden rasvaus
- / Lisää vedenpainetta
- / Vaihda valitsin



△ SÄKERHETSANVISNINGAR

- △ Handskar ska bäras under monteringsarbetet så att man kan undvika kläm- och skärskadorna werden.
- △ Produkten får bara användas till kroppshygien med bad och dusch.
- △ Stora tryckskillnader mellan anslutningarna för varmt och kallt vatten måste utjämnas.

MONTERINGSANVISNINGAR

- / Det måste undersökas om produkten har transportskador innan den monteras. Efter monteringen accepteras inga transport- eller ytskiktsskador.
- / Ledningarna och blandaren måste monteras, spolats igenom och kontrolleras enligt de gällande normerna.
- / De installationsriktlinjer som gäller i länderna ska följas.

TEKNISKA DATA

Driftstryck:	max. 1 MPa
Rek. driftstryck:	0,1 - 0,5 MPa
Tryck vid provtryckning:	1,6 MPa
	(1 MPa = 10 bar = 147 PSI)
Varmvattentemperatur:	max. 70°C
Rek. varmvattentemp.:	65°C
Termisk desinfektion:	max. 70°C / 4 min

Produkten är enbart avsedd för dricksvatten!

SYMBOLFÖRKLARING



Använd inte silikon som innehåller ättiksyra!



JUSTERING (se sidan 34)

Ställa in varmvattenregleringen. Tillsammans med varmvattenberedare rekommenderas inte en varmvattenspär.



MÅTTEN (se sidan 31)



FLÖDESSCHEMA

(se sidan 31)

fri genomströmning

① Avlopp dusch

② Avlopp kar



HANTERING (se sidan 35)



RENGÖRING (se sidan 38)



RESERVDELAR

(se sidan 36)

XXX = Färgkodning

000 = krom

340 = Brushed Black Chrome

800 = rostfri-optik



TESTSIGILL (se sidan 39)

STÖRNING	ORSAK	ÅTGÄRD
/ Blandare är trög	/ Patron defekt, förkalkad	/ Byt ut patron
/ Blandare droppar	/ Patron defekt	/ Byt ut patron
/ För låg varmvattentemperatur, inget kallvatten. Varmvattenberedaren slår på när kallvatten väljs.	/ Varmvattenreglering felaktigt inställd / Korsflöde	/ Ställ in varmvattenreglering / Byt ut patron
/ Omkopplare fungerar inte	/ Avlagringar / För lågt vattentryck / Omkopplare defekt	/ Rengör omkastare/smörj O-ringar / Öka vattentrycket / Byt ut omkopplare

△ SAUGUMO TECHNIKOS NURODYMAI

- △ Apsaugai nuo užspaudimo ir įsijovimo montavimo metu mūvėkite pirštines.
- △ Gaminys turi būti naudojamas tik maudymuisi, kūno higienai ir švarai palaikyti.
- △ Turi būti išlyginti šalto ir karšto slėgio nelygumai.

MONTAVIMO INSTRUKCIJA

- / Prieš montuojant būtina patikrinti, ar gaminys nebuvo pažeistas transportavimo metu. Sumontavus pretenzijos dėl transportavimo ir paviršiaus pažeidimų nepriimamos.
- / Vamzdžiai ir sujungimai turi būti montuojami, plaunami ir tikrinami pagal galiojančias normas.
- / Laikykitės atitinkamoje šalyje galiojančių direktyvų dėl įrengimo.

TECHNINIAI DUOMENYS

Darbinis slėgis: ne daugiau kaip 1 MPa
 Rekomenduojamas slėgis: 0,1 - 0,5 MPa
 Bandomasis slėgis: 1,6 MPa

(1 MPa = 10 barų = 147 PSI)

Karšto vandens temperatūra: ne daugiau kaip 70°C
 Rekomenduojama karšto vandens temperatūra: 65°C
 Terminis dezinfekavimas: ne daugiau kaip 70°C / 4 min

Produktas skirtas tik geriamajam vandeniui!

SIMBOLIO APRAŠYMAS



Nenaudokite silikono, kurio sudėtyje yra acto rūgšties!



REGULIAVIMAS (žr. psl. 34)
 Karšto vandens ribojimas. Kartu su cirkuliaciniais šildytuvais nerekomenduojama naudoti karšto vandens blokavimo įtaisų.



IŠMATAVIMAI (žr. psl. 31)



PRALAUDUMO DIAGRAMA
 (žr. psl. 31)

laisvas vandens pralaidumas

① Dušo išleidimas

② Vonios išleidimas



EKSPLOATACIJA (žr. psl. 35)



VALYMAS (žr. psl. 38)



ATSARGINĖS DALYS
 (žr. psl. 36)

XXX = Spalvos

000 = chrom

340 = Brushed Black Chrome

800 = plienas



BANDYMO PAŽYMA (žr. psl. 39)

GEDIMAS

- / Sunkiai sukiojama rankenėlė
- / Maišytuvus praleidžia vandenį
- / Per maža karšto vandens temperatūra, nėra šalto vandens. Momentinis pašildytojas pradeda veikti, kai naudojamas šalta vanduo
- / Perjungėjas nefunkcionuoja

PRIEŽASTIS

- / Kasetė pažeista, užkalkėjusi
- / Kasetė pažeista
- / Neteisingai nustatytas karšto vandens ribotuvus
- / Kryžminė srovė
- / Apanšos
- / Nepakankamas vandens spaudimas
- / Pažeistas perjungėjas

PRIEMONĖ

- / Pakeisti kasetę
- / Pakeisti kasetę
- / Nustatyti karšto vandens ribotuvą
- / Pakeisti kasetę
- / Išvalykite atsukimą/sutepkite O-žiedus
- / Pakelti vandens spaudimą
- / Pakeisti perjungėją



△ SIGURNOSNE UPUTE

- △ Prilikom montaže se radi sprječavanja prignječenja i posjekotina moraju nositi rukavice.
- △ Proizvod se smije primjenjivati samo za kupanje, tuširanje i osobnu higijenu.
- △ Velika razlika u pritisku između vruće i hladne vode mora biti izbalansirana.

UPUTE ZA MONTAŽU

- / Prije montaže mora se provjeriti je li proizvod oštećen prilikom transporta. Nakon ugradnje se ne priznaju nikakve reklamacije koje se odnose na površinska i transportna oštećenja.
- / Cijevi i armatura moraju biti postavljeni, isprani i testirani prema važećim normama.
- / Obvezno se moraju uvažiti propisi o instalacijama koji vrijede u dotičnoj zemlji.

TEHNIČKI PODATCI

Najveći dopušteni tlak:	tlak 1 MPa
Preporučeni tlak:	0,1 - 0,5 MPa
Probni tlak:	1,6 MPa
	(1 MPa = 10 bar = 147 PSI)
Temperatura vruće vode:	tlak 70°C
Preporučena temperatura vruće vode:	65°C
Termička dezinfekcija:	tlak 70°C / 4 min

Proizvod je koncipiran isključivo za pitku vodu!

OPIS SIMBOLA



Nemojte koristiti silikon koji sadrži octenu kiselinu!



REGULACIJA (pogledaj stranicu 34)
Namještanje limitera tople vode. U kombinaciji s protočnim bojlerima nije preporučljiva primjena sustava za blokiranje dotoka tople vode.



MJERE (pogledaj stranicu 31)



DIJAGRAM PROTOKA
(pogledaj stranicu 31)
slobodan protok

- ① Ogranak tuš
- ② Ogranak kada



UPOTREBA (pogledaj stranicu 35)



ČIŠĆENJE (pogledaj stranicu 38)



REZERVNI DJELOVI
(pogledaj stranicu 36)

- XXX = Boje
- 000 = krom
- 340 = Brushed Black Chrome
- 800 = plemeniti čelik



OZNAKA TESTIRANJA
(pogledaj stranicu 39)

GREŠKA	UZROK	OTKLANJANJE
/ Ručica se zaglavila	/ Neispravan uložak Taloženje kamenca	/ Zamijenite uložak
/ Slavina kaplje	/ Neispravan uložak	/ Zamijenite uložak
/ Preniska temperatura vruće vode, nedostatak hladne vode. Protočni bojler se pali pri podešenoj funkciji za protok hladne vode	/ Limiter vruće vode nije dobro podešen / Križni tok vode	/ Podesite limiter vruće vode / Zamijenite uložak
/ Selektor ne radi	/ Naslage / Prenizak tlak vode / Selektor je neispravan	/ Čišćenje selektora i podmazivanje O-prstenova / Povećajte tlak vode / Zamijenite selektor

△ GÜVENLİK UYARILARI

- △ Montaj esnasında ezilme ve kesilme gibi yaralanmaları önlemek için eldiven kullanılmalıdır.
- △ Ürün yalnızca banyo, hijyen ve beden temizliği amaçları doğrultusunda kullanılabilir.
- △ Sıcak ve soğuk su bağlantıları arasında büyük basınç farklılıkları varsa, bu basınç farklılıklarının dengelenmesi gerekir.

MONTAJ AÇIKLAMALARI

- / Montaj işleminden önce ürün nakliye hasarları yönünden kontrol edilmelidir. Montaj işleminden sonra nakliye veya yüzey hasarları için sorumluluk üstlenilmemektedir.
- / Boruların ve armatürün montajı, yıkanması ve kontrolü geçerli normlara göre yapılmalıdır.
- / Ülkelerde geçerli kurulum yönetmeliklerine riayet edilmelidir.

TEKNİK BİLGİLER

İşletme basıncı:	azami 1 MPa
Tavsiye edilen işletme basıncı:	0,1 - 0,5 MPa
Kontrol basıncı:	1,6 MPa
	(1 MPa = 10 bar = 147 PSI)
Sıcak su sıcaklığı:	azami 70°C
Tavsiye edilen su ısı:	65°C
Termik dezenfeksiyon:	azami 70°C/4 dak

Ürün sadece şebeke suyu için tasarlanmıştır!

SİMGE AÇIKLAMASI

Asetik asit içeren silikon kullanmayın!



AYARLAMA (bakınız sayfa 34)

Sıcak su sınırlamasının ayarlanması. Sıcak su kilitinin sürekli ısıtıcıyla kullanılması tavsiye edilmez.



ÖLÇÜLERİ (bakınız sayfa 31)



AKIŞ DİYAGRAMI

(bakınız sayfa 31)

serbest akış

① Su püskürtücü çıkışı

② Tekne çıkışı



KULLANIMI (bakınız sayfa 35)



TEMİZLEME (bakınız sayfa 38)



YEDEK PARÇALAR

(bakınız sayfa 36)

XXX = Renkler

000 = krom

340 = Brushed Black Chrome

800 = paslanmaz çelik - optik



KONTROL İŞARETİ

(bakınız sayfa 39)

ARIZA	SEBEP	YARDIM
/ Batarya kullanımı ağırlaşiyor	/ Kartus Bozulmuş ve kireklenmiş olabilir	/ Kartusu değiştirin
/ Batarya su damlatıyor	/ Kartus bozuk olabilir	/ Kartusu değiştirin
/ Sıcak su sıcaklığı çok düşük, soğuk su yok. Soğuk su seçilince şofben çalışmaya başlıyor.	/ Isı limitleyici düzgün çalışmıyor	/ Isı limitleyiciyi yeniden ayarlayın
	/ Çapraz akış	/ Kartuşu değiştirin
/ Divertör çalışmıyor	/ Çökelmeler	/ Dönüştürücüyü temizleme / O ringleri yağlama
	/ Su basıncı düşük	/ Su basıncını artırın
	/ Divertör arızalı	/ Divertörü değiştirin

△ INSTRUCȚIUNI DE SIGURANȚĂ

- △ La montare utilizați mănuși pentru evitarea contuziunilor și tăierii mâinilor.
- △ Produsul poate fi utilizat doar pentru spălarea, menținerea igienei și curățarea corpului.
- △ Diferențele de presiune mari între alimentarea cu apă rece și apă caldă trebuie echilibrate.

INSTRUCȚIUNI DE MONTARE

- / Înainte de instalare verificați, dacă produsul prezintă deteriorări de transport. După instalare garanția nu acoperă deteriorările de transport și cele de suprafață.
- / Conductele și bateriile trebuie montate, spălate și verificate conform normelor în vigoare.
- / Respectați reglementările referitoare la instalare valabile în țara respectivă.

DATE TEHNICE

Presiune de funcționare:	max. 1 MPa
Presiune de funcționare recomandată:	0,1 - 0,5 MPa
Presiune de verificare:	1,6 MPa
	(1 MPa = 10 bar = 147 PSI)
Temperatura apei calde:	max. 70°C
Temperatura recomandată a apei calde:	65°C
Dezinfecție termică:	max. 70°C/4 min

Produsul este destinat exclusiv pentru apă potabilă.

DESCRIEREA SIMBOLURILOR



Nu utilizați silicon cu conținut de acid acetic!



REGLARE (vezi pag. 34)

Reglarea limitatorului de apă caldă. Nu se recomandă folosirea unui limitator de apă caldă în combinație cu un boiler instant.



DIMENSIUNI (vezi pag. 31)



DIAGRAMA DE DEBIT

(vezi pag. 31)

debit cu curgere liberă

① Orificiu de scurgere duș

② Orificiu de scurgere vană



UTILIZARE (vezi pag. 35)



CURĂȚARE (vezi pag. 38)



PIESE DE SCHIMB

(vezi pag. 36)

XXX = Coduri de culori

000 = crom

340 = Brushed Black Chrome

800 = oțel inox



CERTIFICAT DE TESTARE

(vezi pag. 39)

DERANJAMENT	CAUZA	MĂSURI DE REMEDIERE
/ Bateria se mișcă dificil	/ Cartuș defect din cauza depunerilor de calcar	/ Schimbați cartușul.
/ Bateria picură	/ Cartuș defect	/ Schimbați cartușul.
/ Temperatura apei este prea mică, nu este apă rece. Boilerul instant pornește când se dă drumul la apa rece	/ Limitarea temperaturii apei calde setată incorect. / Curgere încrucișată (apa rece în intră în conducta de apă caldă și invers)	/ Setați limitarea temperaturii apei calde. / Schimbați cartușul.
/ Cartușul nu funcționează.	/ Depuneri / Presiune apă prea mică / Cartuș defect	/ Curățați inversorul/ungeți inelele O / Măriți presiunea de apă / Schimbați cartușul.



Δ ΥΠΟΔΕΙΞΕΙΣ ΑΣΦΑΛΕΙΑΣ

- Δ Για να αποφύγετε τραυματισμούς κατά τη συναρμολόγηση πρέπει να φοράτε γάντια.
- Δ Το προϊόν επιτρέπεται να χρησιμοποιείται μόνο σαν μέσο λουτρού, υγιεινής και καθαρισμού του σώματος.
- Δ Οι διαφορές της πίεσης μεταξύ της σύνδεσης κρύου και ζεστού νερού θα πρέπει να αντισταθμίζονται.

ΟΔΗΓΙΕΣ ΣΥΝΑΡΜΟΛΟΓΗΣΗΣ

- / Πριν τη συναρμολόγηση πρέπει να εξεταστεί το προϊόν για ζημιές μεταφοράς. Μετά την εγκατάσταση δεν αναγνωρίζονται ζημιές από τη μεταφορά ή επιφανειακές ζημιές.
- / Οι σωλήνες και η μπαταρία πρέπει να τοποθετηθούν σύμφωνα με τα ισχύοντα πρότυπα, να τεθούν υπό πίεση και να δοκιμαστούν.
- / Θα πρέπει να τηρούνται οι οδηγίες εγκατάστασης που ισχύουν σε κάθε κράτος.

ΤΕΧΝΙΚΑ ΧΑΡΑΚΤΗΡΙΣΤΙΚΑ

Λειτουργία πίεσης: έως 1 MPa
 Συνιστώμενη λειτουργία πίεσης: 0,1 - 0,5 MPa
 Πίεση ελέγχου: 1,6 MPa
(1 MPa = 10 bar = 147 PSI)
 Θερμοκρασία ζεστού νερού: έως 70°C
 Συνιστώμενη θερμοκρασία ζεστού νερού: 65°C
 Θερμική απολύμανση: έως 70°C/4 min

Το προϊόν έχει σχεδιαστεί αποκλειστικά για πόσιμο νερό!

ΠΕΡΙΓΡΑΦΗ ΣΥΜΒΟΛΩΝ

Μην χρησιμοποιείτε σιλικόνη που περιέχει οξέλι οξύ!



ΡΥΘΜΙΣΗ (βλ. Σελίδα 34)
 Ρύθμιση του δοσομετρητή ζεστού νερού. Δεν συνιστάται η διάταξη φραγής ζεστού νερού σε συνδυασμό με ταχυθερμοσίφωνα.



ΔΙΑΣΤΑΣΕΙΣ (βλ. Σελίδα 31)



ΔΙΑΓΡΑΜΜΑ ΡΟΗΣ
 (βλ. Σελίδα 31)

Ελεύθερη ροή

Ⓐ Εξοδος ντους

Ⓑ Εξοδος μπανιέρας



ΧΕΙΡΙΣΜΟΣ (βλ. Σελίδα 35)



ΚΑΘΑΡΙΣΜΟΣ (βλ. Σελίδα 38)



ΑΝΤΑΛΛΑΚΤΙΚΑ

(βλ. Σελίδα 36)

XXX = Χρώματα

000 = Επιχρωμιωμένο

340 = Brushed Black Chrome

800 = οπτική ανοξείδωτου χάλυβα

ΣΗΜΑ ΕΛΕΓΧΟΥ (βλ. Σελίδα 39)



ΒΛΑΒΗ	ΑΙΤΙΑ	ΔΙΟΡΘΩΣΗ
/ Σκληρή μπαταρία (μείκτης)	/ Ελαττωματικό φυσιγγίο, άλατα	/ Αλλαγή φυσιγγίου
/ Η μπαταρία στάζει	/ Ελαττωματικό φυσιγγίο	/ Αλλαγή φυσιγγίου
/ Χαμηλή θερμοκρασία ζεστού νερού, καθόλου κρύο νερό. Ο ταχυθερμοσίφωνα ενεργοποιείται, όταν επιλέγεται το κρύο νερό.	/ Λάθος ρύθμιση της περιοριστικής διάταξης ζεστού νερού	/ Ρυθμίστε την περιοριστική διάταξη του ζεστού νερού
/ Ο διακόπτης επιλογής δεν λειτουργεί	/ Σταυροειδής ροή	/ Αλλαγή φυσιγγίου
	/ Άλατα	/ Καθαρίστε τον ρυθμιστή νερού/ λιπάνετε τους στεγανωτικούς δακτυλίους
	/ Ανεπαρκής πίεση νερού	/ Αυξήστε την πίεση του νερού
	/ Βλάβη στο διακόπτη επιλογής	/ Αλλάξτε το διακόπτη επιλογής

⚠ VARNOSTNA OPOZORILA

- ⚠ Pri montaži je treba nositi rokavice, da se preprečijo poškodbe zaradi zmečkanja ali urezov.
- ⚠ Ta izdelek se sme uporabljati le z namenom umivanja, vzdrževanja higiene in telesne nege.
- ⚠ Velike razlike v tlaku med priključkom za mrzlo in priključkom za toplo vodo je potrebno izravnati.

NAVODILA ZA MONTAŽO

- / Pred montažo je treba izdelek preveriti glede morebitnih transportnih poškodb. Po vgradnji transportne ali površinske poškodbe ne bodo več priznane.
- / Cevi in armaturo je treba montirati, izprati in preveriti po veljavnih standardih.
- / Upoštevati je treba pravilnike o inštalacijah, ki veljajo v posamezni državi.

TEHNIČNI PODATKI

Delovni tlak:	maks. 1 MPa
Priporočeni delovni tlak:	0,1 - 0,5 MPa
Preskusni tlak:	1,6 MPa
	(1 MPa = 10 bar = 147 PSI)
Temperatura tople vode:	maks. 70°C
Priporočena temperatura tople vode:	65°C
Termična dezinfekcija:	maks. 70°C / 4 min

Proizvod je zasnovan izključno za sanitarno vodo!

OPIS SIMBOLA



Ne smete uporabiti silikona, ki vsebuje ocatno kislino!



JUSTIRANJE (glejte stran 34)

Nastavitev omejevalnika tople vode. V povezavi s pretočnimi grelniki uporaba zapore tople vode ni priporočljiva.



MERE (glejte stran 31)



DIAGRAM PRETOKA

(glejte stran 31)

prost pretok

① Odvod prhe

② Odvod banje



UPRAVLJANJE (glejte stran 35)



ČIŠČENJE (glejte stran 38)



REZERVNI DELI

(glejte stran 36)

XXX = Barve

000 = krom

340 = Brushed Black Chrome

800 = videz legiranega jekla



PRESKUSNI ZNAK (glejte stran 39)

NAPAKA	VZROK	POMOČ
/ Težko premikanje armature	/ Pokvarjen vložek, poapneno	/ Zamenjajte vložek
/ Iz armature kaplja	/ Pokvarjen vložek	/ Zamenjajte vložek
/ Prenizka temperatura tople vode, ni mrzle vode. Pretočni grelnik se sproži, kadar izberete mrzlo vodo.	/ Omejevalnik tople vode ni pravilno nastavljen	/ Nastavite omejevalnik tople vode
/ Preklopnik ne deluje	/ Križni tok	/ Zamenjajte vložek
	/ Obloge	/ Očistite premičnik/namastite obročno tesnilo
	/ Prenizek vodni tlak	/ Povečajte vodni tlak
	/ Preklopnik je pokvarjen	/ Zamenjajte preklopnik

MONTAŽA (glejte stran 32)



OHUTUSJUHISED

- ⚠ Kandke paigaldamisel muljumis- ja löikevigastuste vältimiseks kindaid.
- ⚠ Toodet tohib kasutada ainult pesemis-, hügieeni- ja kehapihustamiseesmärkidel.
- ⚠ Kui külma ja kuuma vee ühenduste surve on väga erinev, tuleb need tasakaalustada.

PAIGALDAMISJUHISED

- / Enne paigaldamist tuleb toodet kontrollida transpordikahjustuste osas. Pärast paigaldamist ei tunnustata enam transpordi- või pinnakahjustuste kaebuseid.
- / Voolikute ja segisti paigaldamisel, loputamisel ja kontrollimisel tuleb lähtuda kehtivatest normatiividest.
- / Vastavas riigis kehtivaid paigalduseeskirju tuleb järgida.

TEHNILISED ANDMED

Töörõhk	maks. 1 MPa
Soovitatav töörõhk:	0,1 - 0,5 MPa
Kontrollsurve:	1,6 MPa (1 MPa = 10 baari = 147 PSI)
Kuuma vee temperatuur:	maks. 70°C
Soovitatav kuuma vee temperatuur:	65°C
Terminline desinfektsioon:	maks. 70°C / 4 min

Toode on ette nähtud eranditult joogivee jaoks!

SÜMBOLITE KIRJELDUS



Ärge kasutage äädikhapet sisaldavat silikoonil



REGULEERIMINE (vt lk 34)
Sooja vee piirangu seadistamine. Ühenduses boileritega ei ole sooja vee blokeeringu soovitatav.



MÕÕTUDE (vt lk 31)



LÄBIVOOLUDIAGRAMM
(vt lk 31)

ärvoolu surve

① Duši väljund

② Vanni väljund



KASUTAMINE (vt lk 35)



PUHASTAMINE (vt lk 38)



VARUOSAD
(vt lk 36)

XXX = Värv

000 = kroom

340 = Brushed Black Chrome

800 = roostevaba optik



KONTROLLSERTIFIKAAT (vt lk 39)

RIKE	PÕHIUS	LAHENDUS
/ Segisti käib raskelt	/ Tööelement on katkine, lubiastunud	/ Vahetage tööelement
/ Segisti tilgab	/ Tööelement on katkine	/ Vahetage tööelement
/ Liiga madal sooja vee temperatuur, külma vett pole. Läbivoolu boiler hakkab tööle, kui on valitud külm vesi.	/ Kuuma vee piirang valesti seatud / Ristvool	/ Seadke kuuma vee piirang / Vahetage tööelement
/ Ümberlüüti ei tööta	/ Setted	/ Ümberlüüti puhastamine / O-tihendite määrimine
	/ Vee surve liiga madal	/ Tõstke vee survet
	/ Ümberlüüti defektne	/ Ümberlüüti välja vahetada

△ DROŠĪBAS NORĀDES

- △ Montāžas laikā, lai izvairītos no saspiedumiem un iegrīzumiem, nepieciešams nēsāt cimdus.
- △ Šo produktu drīkst izmantot tikai, lai mazgātos, higiēnai un ķermeņa tīrīšanai.
- △ Jāizlīdzina spiediena atšķirības starp aukstā un karstā ūdens pievadiem.

NORĀDĪJUMI MONTĀŽAI

- / Pirms montāžas nepieciešams pārbaudīt, vai produktam transportēšanas laikā nav radušies bojājumi. Pēc iebūvēšanas bojājumi, kas radušies transportēšanas laikā, vai virsmas bojājumi netiek atzīti.
- / Caurulvadi un armatūra ir jāuzstāda, jāizskalo un jāpārbauda saskaņā ar spēkā esošajiem standartiem.
- / Jāievēro attiecīgās valsts spēkā esošās montāžas prasības.

TEHNISKIE DATI

Darba spiediens:	maks. 1 MPa
Ieteicamais darba spiediens:	0,1 - 0,5 MPa
Pārbaudes spiediens:	1,6 MPa
	(1 MPa = 10 bar = 147 PSI)
Karstā ūdens temperatūra:	maks. 70°C
Ieteicamā karstā ūdens temperatūra:	65°C
Termiskā dezinfekcija :	maks. 70°C / 4 min

Izstrādājums ir paredzēts tikai dzeramajam ūdenim!

SIMBOLU NOZĪME



Neizmantojot silikonu, kas satur etiķskābi!



IEREGULĒŠANA (skat. lpp. 34)
Karsta ūdens ierobežotāja regulēšana. Kopā ar caurteces sildītājiem nav ieteicams izmantot ūdens bloķētāju.



IZMĒRUS (skat. lpp. 31)



CAURPLŪDES DIAGRAMMA
(skat. lpp. 31)
brīva caurplūde
① Dušas izeja
② Vannas izeja



LIETOŠANA (skat. lpp. 35)



TĪRĪŠANA (skat. lpp. 38)



REZERVES DAĻAS
(skat. lpp. 36)
XXX = Krāsu kodi
000 = hroma
340 = Brushed Black Chrome
800 = tērauda



PĀRBAUDES ZĪME (skat. lpp. 39)

TRAUCĒJUMS	IEMESLS	BOJĀJUMU NOVĒRŠANA
/ Iaucējkrāns smagi grozāms	/ Bojāta kartuša, aizkalkojusies	/ Nomainīt kartušu
/ Iaucējkrāns pil	/ Bojāta kartuša	/ Nomainīt kartušu
/ Pārāk zema ūdens temperatūra, nav aukstā ūdens, izvēloties auksto ūdeni, sāk darboties caurteces sildītājs	/ Nepareizi noregulāta karstā ūdens bloķēšana	/ Noregulēt karstā ūdens ierobežošanu
/ Pārslēdzējs nestrādā	/ Ūdens sajaukšanās	/ Nomainīt kartušu
	/ Nogulsnes	/ Tīriet pārslēdzēju / eļļojiet blīvējošos gredzenus
	/ Nepietiekams ūdens spiediens	/ Paaugstināt ūdens spiedienu
	/ Bojāts pārslēdzējs	/ Nomainīt pārslēdzēju

MONTĀŽA (skat. lpp. 32) 

△ SIGURNOSNE NAPOMENE

- △ Prilikom montaže se radi sprečavanja prignječenja i posekotina moraju nositi rukavice.
- △ Proizvod sme da se koristi samo za kupanje, tuširanje i ličnu higijenu.
- △ Velika razlika u pritisku između vruće i hladne vode mora biti izbalansirana.

INSTRUKCIJE ZA MONTAŽU

- / Pre montaže se mora proveriti da li je proizvod oštećen pri transportu. Nakon ugradnje se ne priznaju nikakve reklamacije koje se odnose na površinska i transportna oštećenja.
- / Vodovi i armatura moraju biti postavljeni, isprani i testirani prema važećim normama.
- / Treba se pridržavati propisa koji u određenim zemljama važe za instalacije.

TEHNIČKI PODACI

Radni pritisak:	maks. 1 MPa
Preporučeni radni pritisak:	0,1 - 0,5 MPa
Probni pritisak:	1,6 MPa
	(1 MPa = 10 bar = 147 PSI)
Temperatura vruće vode:	maks. 70°C
Preporučena temperatura vruće vode:	65°C
Termička dezinfekcija:	maks. 70°C / 4 min

Proizvod je koncipiran isključivo za pijuću vodu!

OPIS SIMBOLA



Nemojte koristiti silikon koji sadrži sirćetnu kiselinu!



PODEŠAVANJE (vidi stranu 34)
Podešavanje ograničivača tople vode.
U kombinaciji sa protočnim bojlerima ne preporučuje se primena sistema za blokiranje dotoka tople vode.



MERE (vidi stranu 31)



DIJAGRAM PROTOKA
(vidi stranu 31)
slobodan protok

- ① Ogranak tuš
- ② Ogranak kada



UKOVANJE (vidi stranu 35)



ČIŠĆENJE (vidi stranu 38)



REZERVNI DELOVI
(vidi stranu 36)
XXX = Oznake boja

- 000 = hrom
- 340 = Brushed Black Chrome
- 800 = dezen plemeniti čelik



ISPITNI ZNAK (vidi stranu 39)

SMETNJA	UZROK	POMOĆ
/ Ručica se zaglavila	/ Neispravna kartuša, nataloženi kamenac	/ Zamenite kartušu
/ Slavina kaplje	/ Neispravna kartuša	/ Zamenite kartušu
/ Preniska temperatura tople vode, nema hladne vode. Protočni bojler se pali iako je pušten hladna voda.	/ Ograničivač vruće vode nije dobro podešen	/ Podesite ograničivač vruće vode
/ Preusmerivač ne radi	/ Ukršteni tok vode	/ Zamenite kartušu
	/ Naslage	/ Čišćenje preusmerivača i podmazivanje O-prstenova
	/ Prenizak pritisak vode	/ Povećajte pritisak vode
	/ Preusmerivač je neispravan	/ Zamenite preusmerivač

△ SIKKERHETSHENVISNINGER

- △ Bruk hansker under montasjen for å unngå klem- og kuttskader.
- △ Produktet skal kun brukes for bade-, hygiene- og kroppshygiene.
- △ Store trykkdifferanser mellom kaldt- og varmtvannstilkoblinger skal utlignes.

MONTAGEHENVISNINGER

- / Før montasjen skal produktet sjekkes for transportskader. Etter monteringen aksepteres ikke noen transport- eller overflateskader.
- / Ledningene og armaturen skal monteres, spyles og sjekkes iht. de gyldige normer.
- / Gjeldende retningslinjer for rørleggerarbeid i de enkelte land skal følges.

TEKNISKE DATA

Driftstrykk	maks. 1 MPa
Anbefalt driftstrykk:	0,1 - 0,5 MPa
Prøvetrykk	1,6 MPa
	(1 MPa = 10 bar = 147 PSI)
Varmtvannstemperatur	maks. 70°C
Anbefalt temperatur for varmt vann	65°C
Termisk desinfisering:	maks. 70°C / 4 min

Produktet er utelukkende designet for drikkevann!

SYMBOLBESKRIVELSE



Ikke bruk silikon som inneholder eddiksyre!



JUSTERING (se side 34)

Innstilling av varmtvannsbegrensning. I forbindelse med gjennomstrømningsvarmere er det ikke anbefalt å bruke en varmtvannspærre.



MÅL (se side 31)



GJENNOMSTRØMNINGSDIAGRAM (se side 31)

fri gjennomstrømning

① Utgang dusj

② Utgang kar



BETJENING (se side 35)



RENGJØRING (se side 38)



SERVICEDELER

(se side 36)

XXX = Fargekode

000 = krom

340 = Brushed Black Chrome

800 = rustfritt stål optikk



PRØVEMERKE (se side 39)

FEIL	ÅRSAK	FEILRETTELSE
/ Armatur ikke lett bevegelig	/ Kartusj defekt, forkalkning	/ Kartusj byttes
/ Armatur drypper	/ Kartusj defekt	/ Kartusj byttes
/ For lav varmtvannstemperatur, ikke noe kaldtvann, gjennomstrømningsvarmvarmer slår seg på når det velges kaldt vann.	/ Varmtvannsbegrensning er feil innstilt / Krysstrømning	/ Varmtvannsbegrensning innstilles / Kartusj byttes
/ Omstiller fungerer ikke	/ Avleiringer / For lavt vanntrykk / Omstiller defekt	/ Rengjøre omstiller/smøre O-ringer / Øke vanntrykk / Omstiller byttes

⚠ УКАЗАНИЯ ЗА БЕЗОПАСНОСТ

- ⚠ При монтажа трябва да се носят ръкавици, за да се избегнат наранявания поради притискане или порязване.
- ⚠ Позволено е използването на продукта само за къпане, хигиена и цели на почистване на тялото.
- ⚠ Големите разлики в налягането между изводите за студената и топлата вода трябва да се изравняват.

УКАЗАНИЯ ЗА МОНТАЖ

- / Преди монтажа продуктът трябва да се провери за транспортни щети. След монтажа не се признават транспортни или повърхностни щети.
- / Тръбопроводите и арматурата трябва да се монтират, промият и проверят в съответствие с валидните норми.
- / Трябва да бъдат спазвани валидните в съответните страни предписания за инсталиране.

ТЕХНИЧЕСКИ ДАННИ

Работно налягане:	макс. 1 МПа
Препоръчително работно налягане:	0,1 - 0,5 МПа
Контролно налягане:	1,6 МПа
	(1 МПа = 10 bar = 147 PSI)
Температура на горещата вода:	макс. 70°C
Препоръчителна температура на горещата вода:	65°C
Термична дезинфекция:	макс. 70°C / 4 мин

Продуктът е разработен само за питейна вода!

ОПИСАНИЕ НА СИМВОЛИТЕ



Не използвайте силикон, съдържащ оцетна киселина!



ЮСТИРАНЕ (вижте стр. 34)
Настройка на ограничителя за топлата вода.
Във връзка с проточни нагреватели не се поръчва блокировка за топлата вода



РАЗМЕРИ (вижте стр. 31)



ДИАГРАМА НА ПОТОКА
(вижте стр. 31)
свободен поток

- ① Изход разпръсквател
- ② Извод вана



ОБСЛУЖВАНЕ (вижте стр. 35)



ПОЧИСТВАНЕ (вижте стр. 38)



СЕРВИЗНИ ЧАСТИ
(вижте стр. 36)

- XXX = Цветово кодиране
- 000 = хром
- 340 = Brushed Black Chrome
- 800 = оптика на благородна стомана



КОНТРОЛЕН ЗНАК (вижте стр. 39)

НЕИЗПРАВНОСТ	ПРИЧИНА	ПОМОЩ
/ Трудно подвижна арматура	/ Дефектна гилза, покрита с варовик	/ Сменете гилзата
/ Арматурата капе	/ Дефектна гилза	/ Сменете гилзата
/ Твърде ниска температура на топлата вода, няма студена вода. Проточният нагревател се задейства, когато се избере студена вода	/ Ограничението за топлата вода е грушно настроено	/ Настройте ограничението за топлата вода
	/ Кръстосване на потока	/ Сменете гилзата
/ Превключвателят не функционира	/ Отлагания	/ Почистете превключвателя / Смажете О-образните пръстени
	/ Твърде малко налягане на водата	/ Повишаване на налягането на водата
	/ Дефектен превключвател	/ Сменете превключвателя



△ UDHËZIME SIGURIE

- △ Për të evituar lëndimet e pickimeve ose të prerjeve gjatë procesit të montimit duhet që të vishni doreza.
- △ Produkti duhet të përdoret vetëm qëllimet e banjave, të higjienës dhe të larjes së trupit.
- △ Ndryshimet e mëdha të presionit mes lidhjeve të ujit të ftohtë dhe atij të ngrohtë duhen ekuilibruar.

UDHËZIME PËR MONTIMIN

- / Përpara montimit duhet që produkti të kontrollohet për dëmtime nga transporti. Pas instalimit nuk do të njihet asnjë dëmtim nga transporti ose dëmtim i sipërfaqes.
- / Tubacionet dhe rubinetet duhet që të montohen, të shpëlahen dhe të kontrollohen sipas standardeve në fuqi
- / Duhet të respektohen linjat udhëzuese të instalimit, të vlefshme për vendet respektive.

TË DHËNA TEKNIKE

Presioni gjatë punës	maks. 1 MPa
Presioni i rekomanduar:	0,1 - 0,5 MPa
Presioni për provë:	1,6 MPa
	(1 MPa = 10 bar = 147 PSI)
Temperatura e ujit të ngrohtë	maks. 70°C
Temperatura e rekomanduar e ujit të ngrohtë:	65°C
Dezinfektim Termik:	maks. 70°C / 4 min

Produkti është projektuar ekskluzivisht për ujë të pijshëm!

PËRSHKRIMI I SIMBOLIT



Mos përdorni silikon që në përbërje ka acid acetik.



JUSTIMI (shih faqen 34)
Rregullimi i kufizimit me ujë të nxehtë. Nje kombinim me një bojler ujit nuk është i rekomanduar.



PËRMASAT (shih faqen 31)



DIAGRAMI I QARKULLIMIT
(shih faqen 31)
rrijdhja e lirë

- ① Dalja e spërkatëses
- ② Dalja e vaskës



PËRDORIMI (shih faqen 35)



PASTRIMI (shih faqen 38)



PJESËT E SERVISIT
(shih faqen 36)
XXX = Kodimi me anë të ngjyrave
000 = krom
340 = Brushed Black Chrome
800 = optikë çeliku



SHENJA E KONTROLLIT
(shih faqen 39)

DEMTIM	SHKAKU	NDIHME
/ Armatura punon rende	/ Kartusha me defekt, me kalk	/ Kembeni kartushen
/ Armatura pikon	/ Kartusha me defekt	/ Kembeni kartushen
/ Temperaturë e ulët e ujit të ngrohtë, nuk ka ujë të ftohtë. Ngrohësi elektrik i ujit ndizet kur zgjidhet uji i ftohtë.	/ Kufiri i ujit te ngrohte eshte regjistruar gabim	/ Regjistroni kufirin e ujit te ngrohte
/ Kalibruesi nuk funksionon	/ Rriedhje e kryqëzuar.	/ Kembeni kartushen
	/ Dekompozimet	/ Pastroni ndërruesin e pozicionit/ Vajosni unazat O
	/ Presion shumë i ulët i ujit	/ Rrisni presionin e ujit
	/ Kalibruesi me defekt	/ kembeni kalibruesin

وصف الرمز

⚠ تنبيهات الأمان

هام! لا تستخدم السليكون الذي يحتوي على أمحاض!



⚠ يجب إرتداء قفازات لليد أثناء التركيب لتجنب حدوث أخطار الإنحشار أو الجروح.

الضبط (راجع صفحة 34)
ضبط تحديد المياه الدافئة. لا ينصح باستخدام محدد المياه الدافئة مع سخان المياه الوقتي.



⚠ لا يجب استخدام المنتج إلا في أعراض الاستحمام والأعراض الصحية وأعراض تنظيف الجسم.

⚠ يجب أن يكون تيار الماء الساخن والماء البارد متعادلين في الضغط.

تعليمات التركيب

أبعاد (راجع صفحة 31)



/ قبل القيام بعملية التركيب، يجب فحص المنتج للتأكد من خلوه من أية تلفيات ناتجة عن النقل. بعد القيام بعملية التركيب، لن يتم الاعتراف بوجود أية تلفيات سطحية أو تلفيات ناتجة عن عملية النقل.

رسم للصراف
(راجع صفحة 31)
التدفق الحر



/ يجب تركيب وغسيل واختيار التوصيلات وخلطات المياه طبقاً للمعايير السارية.

① صرف الرشاش
② صرف البانيو

/ يجب مراعاة القواعد الخاصة بالتركيب وأعمال السباكة وفقاً للوائح الخاصة بكل بلد.

المواصفات الفنية

التشغيل (راجع صفحة 35)



ضغط التشغيل: الحد الأقصى 1 ميجاباسكال

التنظيف (راجع صفحة 38)



ضغط التشغيل الموصى به: 0,5 - 0,1 ميجاباسكال

ضغط الاختبار: 1,6 ميجاباسكال

قطع الغيار



(1 ميجاباسكال = 10 بار = 147 PSI)

(راجع صفحة 36)

درجة حرارة الماء الساخن: الحد الأقصى 70°C

XXX = الألوان

درجة الحرارة الموصى بها للماء الساخن: 65°C

000 = كروم

الحد الأقصى 4/70°C الدقيقة

Brushed Black Chrome = 340

800 = مظهر الإستنليس سنيل

شهادة اختبار (راجع صفحة 39)



المنتج مخصص فقط لماء الشرب!

العطل	السبب	العلاج والإصلاح
/ الخلاط ثقيل الحركة	/ الخرطوشة تالفة، تراكم عليها الجير	/ قم بتغيير الخرطوشة
/ تساقط قطرات مياه من الخلاط	/ الخرطوشة تالفة	/ قم بتغيير الخرطوشة
/ درجة حرارة الماء الساخن منخفضة	/ محدد الماء الساخن مضبوط بشكل خاطيء	/ قم بضبط محدد الماء الساخن
/ للمياه الفوري يعمل عند استخدام الماء البارد.	/ اندفاع متعاكس للمياه	/ قم بتغيير الخرطوشة
/ المحول لا يعمل	/ الرواسب	/ تنظيف الخلاط وتشحيم الحلقة الدائرية.
	/ ضغط الماء منخفض للغاية	/ ارفع ضغط الماء
	/ المحول تالف	/ قم بتغيير المحول

التركيب (راجع صفحة 32)





AXOR Starck
10416XXX / 10416003

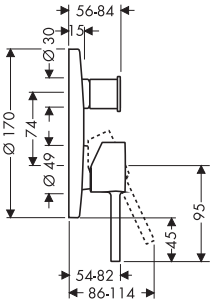

AXOR Starck
10414000

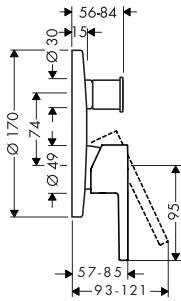

AXOR Starck X
10445000

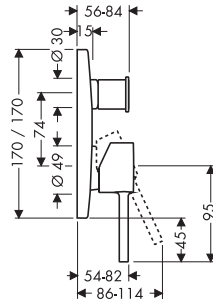

AXOR Uno²
38425000

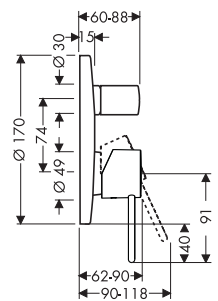

AXOR Citterio M
34425000 / 34425003

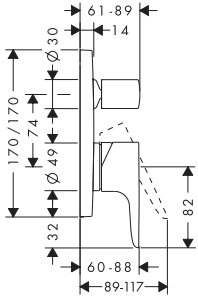

AXOR Citterio
39455000 / 39455003

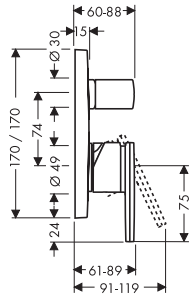

AXOR Citterio E
36455000 / 36455003

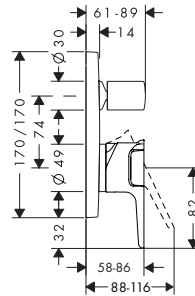

AXOR Starck 10416000 / 10416003 / 10414000

AXOR Starck X 10445000

AXOR Uno² 38425000

AXOR Citterio M 34425000 / 34425003

AXOR Citterio 39455000 / 39455003

AXOR Citterio E 36455000 / 36455003

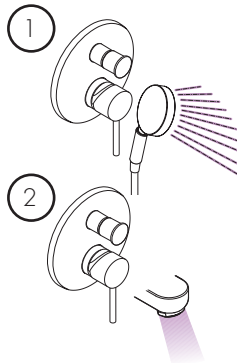
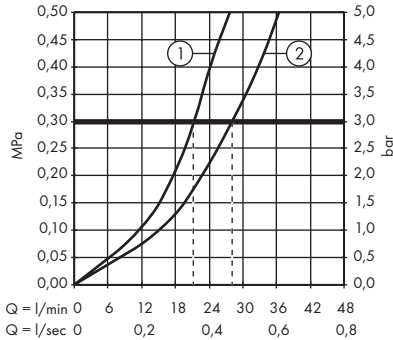

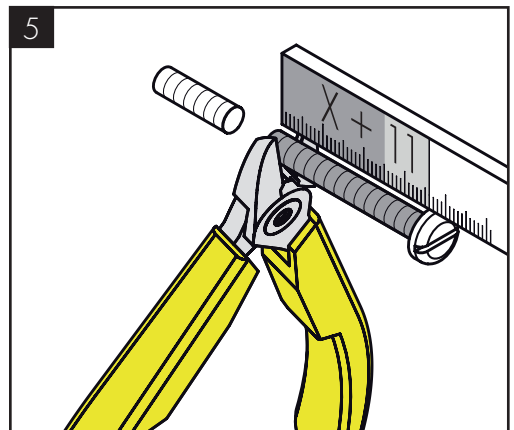
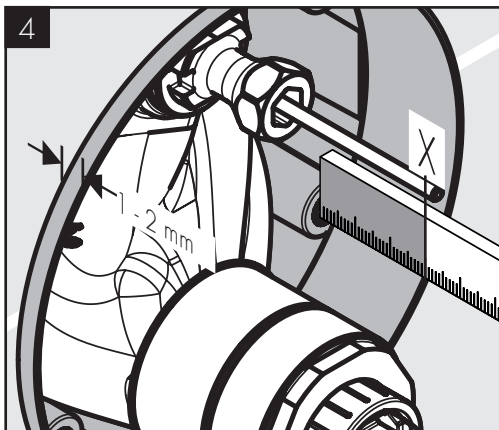
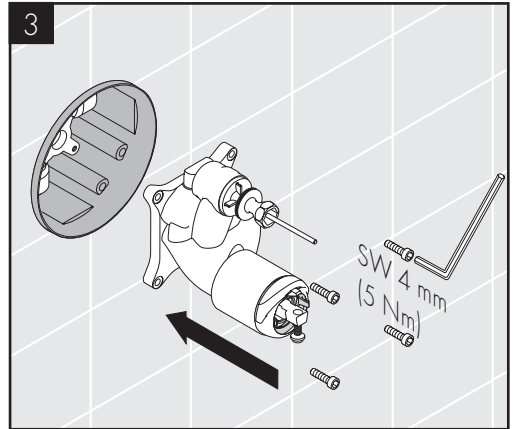
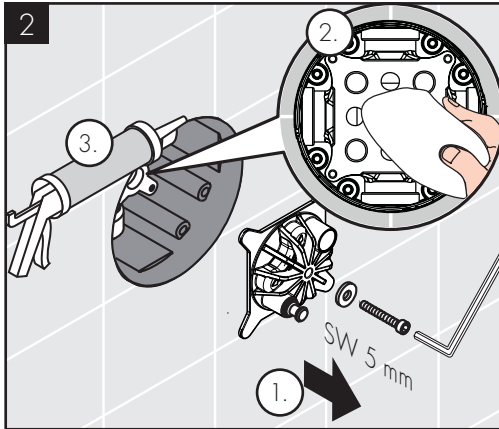
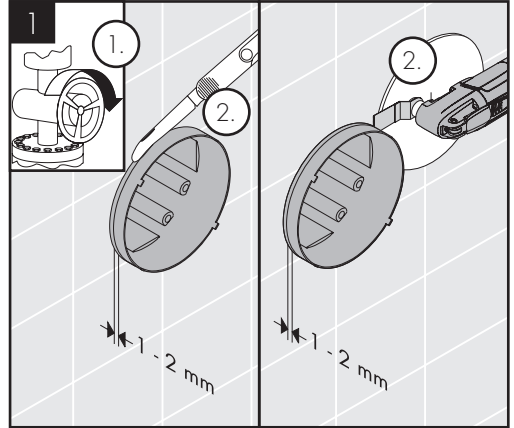
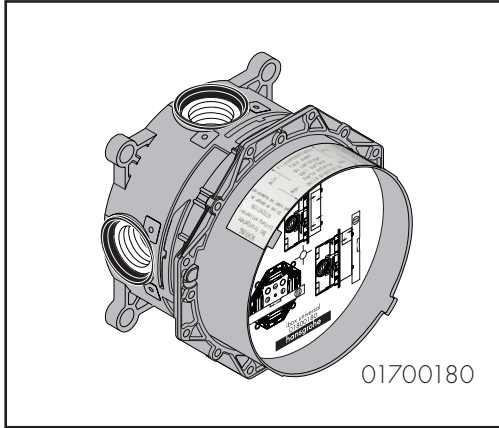

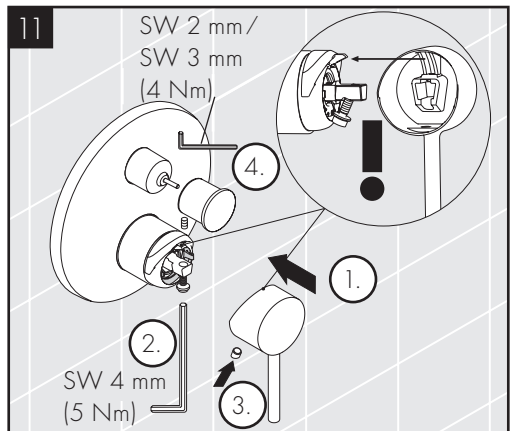
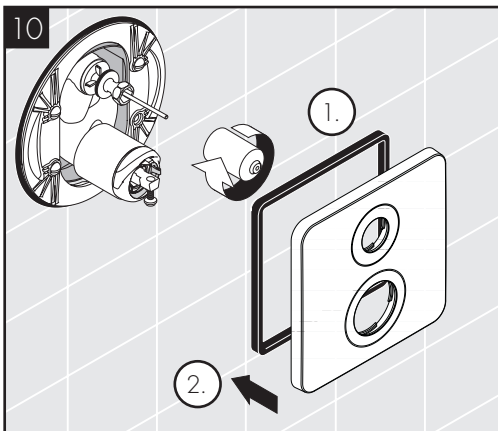
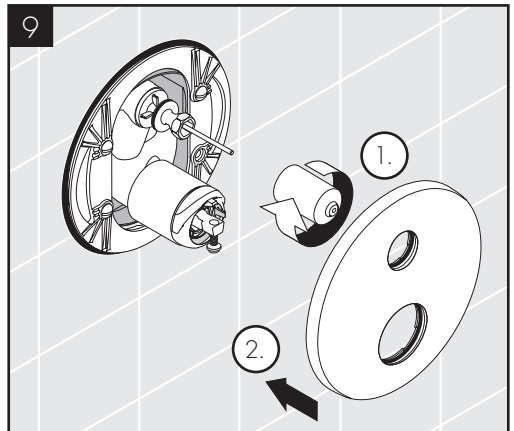
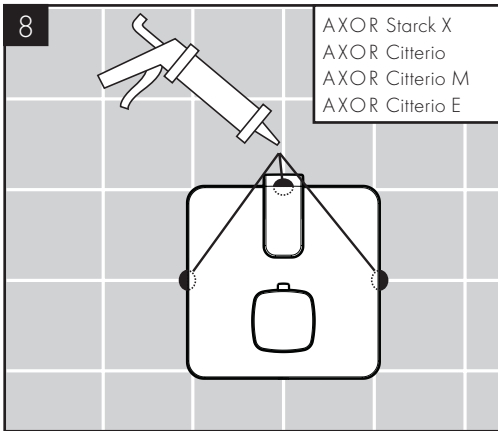
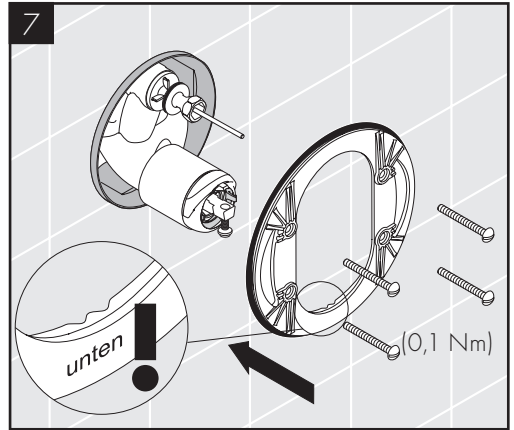
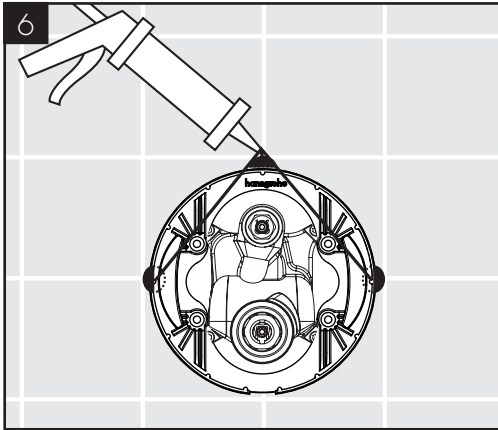

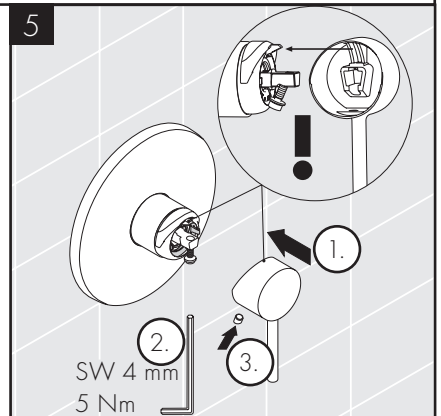
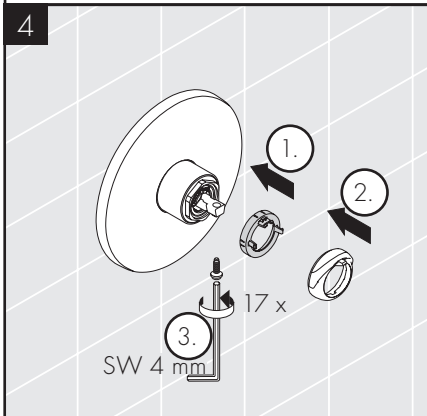
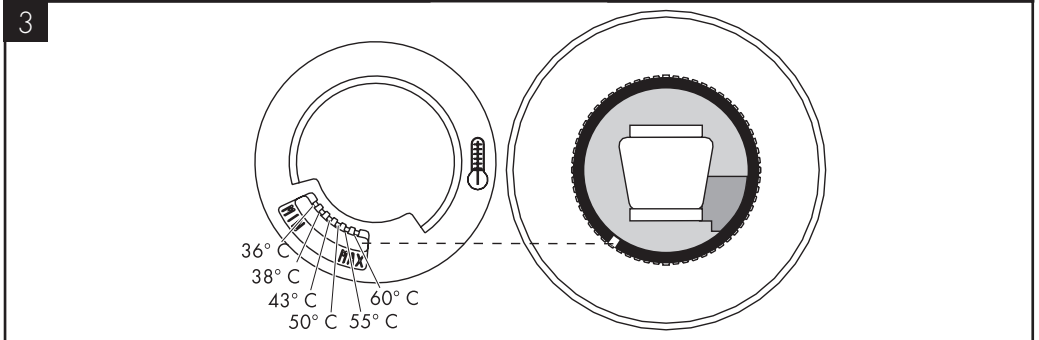
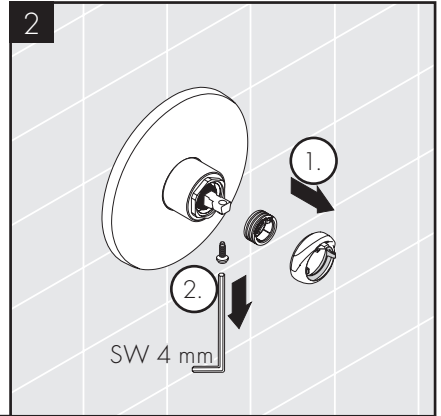
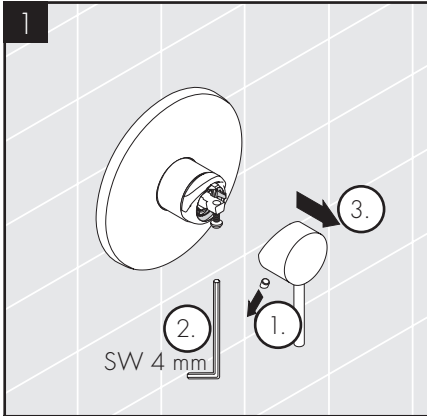

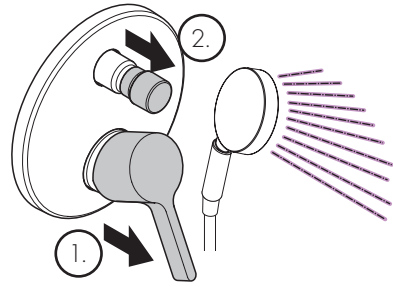
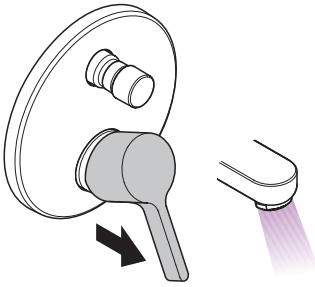

öffnen / ouvert / open / aperto / abierto / open / åbne / abrir / otworzyć / otevřít / otvorit / 开 / открыть / nyitás / avaaminen / öppna / atidaryti / Otvaranje / açmak / deschide / ανοικτό / odpreti / avage / atvērti / otvoriti / åpne / отварање / hape / فتح

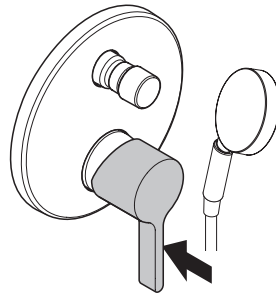
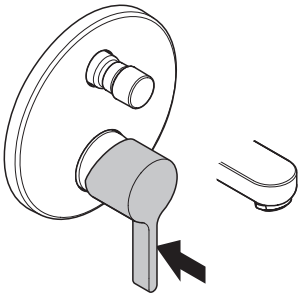

schließen / fermé / close / chiudere / cerrar / sluiten / lukke / fechar / zamknąć / zavřít / uzavriť / 关 / закрыть / bezárás / sulkeminen / stänga / uždaryti / Zatvaranje / kapatmak / închide / κλειστό / zapreti / sulgege / aizvērt / zatvori / lukke / zatvaranje / mbylle / إغلاق

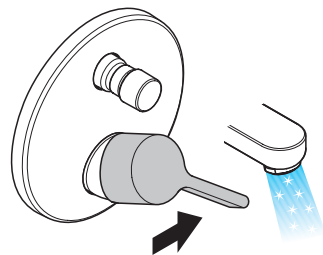
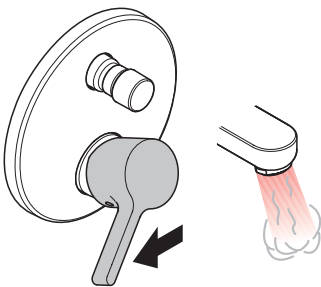

warm / chaud / hot / caldo / caliente / warm / varmt / quente / ciepła / teplá / teplá / 热 / горячая / meleg / lämmin / varmt / karštas / Vruća voda / sıcak / cald / ζεστό / toplo / kuum / karsts / topla / varm / тепло / i ngrohtë / ساخن

kalt / froid / cold / freddo / frío / koud / koldt / fría / zimna / studená / studená / 冷 / холодная / hideg / kylmä / kallt / šaltas / Hladno / soğuk / rece / κρύο / mrzlo / külm / auksts / hladno / kaldt / студено / i fihohtë / بارد

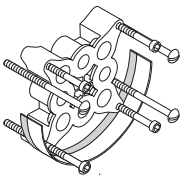
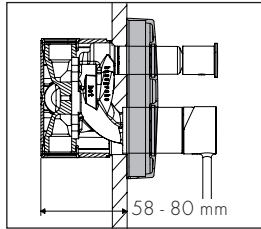
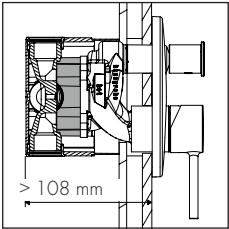
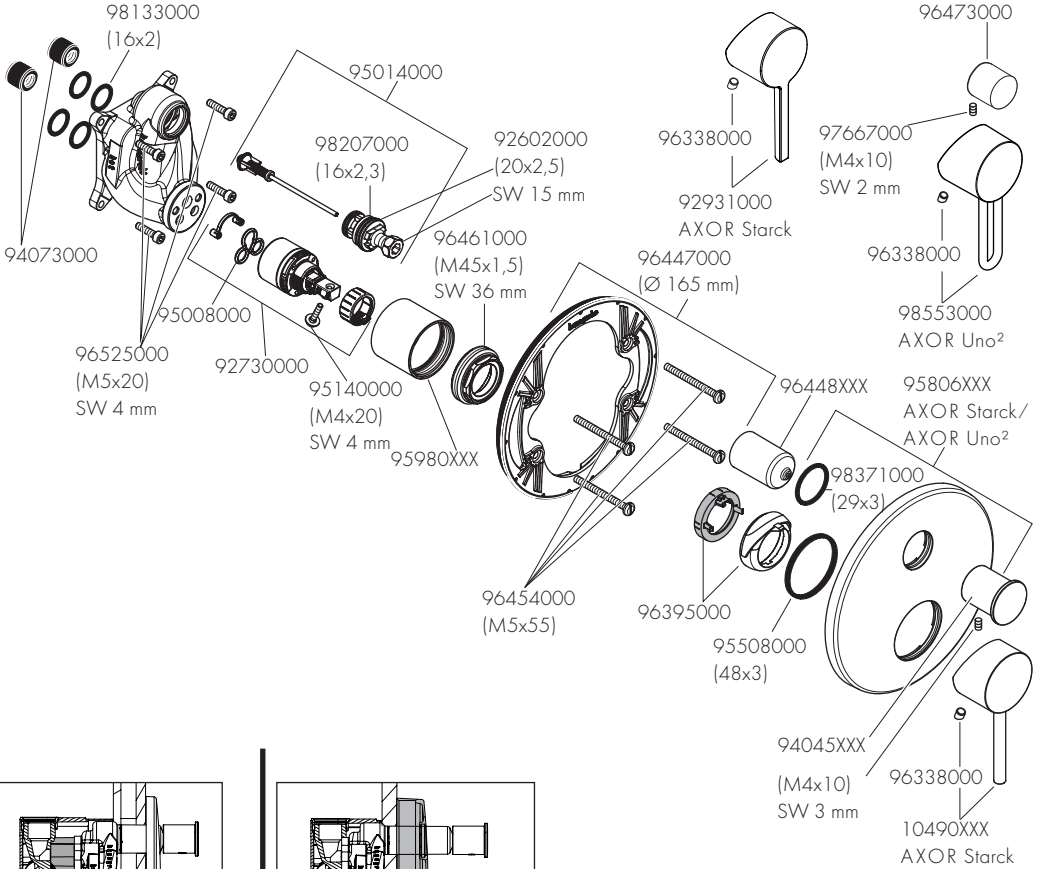

13595000
25 mm

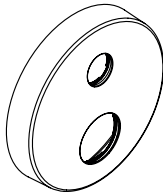

14961000
AXOR Starck /
AXOR Uno
(33 mm)

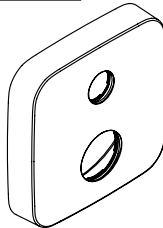

14972000
AXOR Citterio M /
AXOR Citterio E
(33 mm)

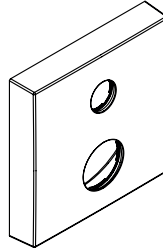

14967000
AXOR Citterio /
AXOR Starck X
(33 mm)



AXOR Starck X 10445000 / AXOR Citterio M 34425000 / AXOR Citterio M 34425003 /
Citterio E 36455000 / Citterio E 36455003 / AXOR Citterio 39455000 / AXOR Citterio 39455003

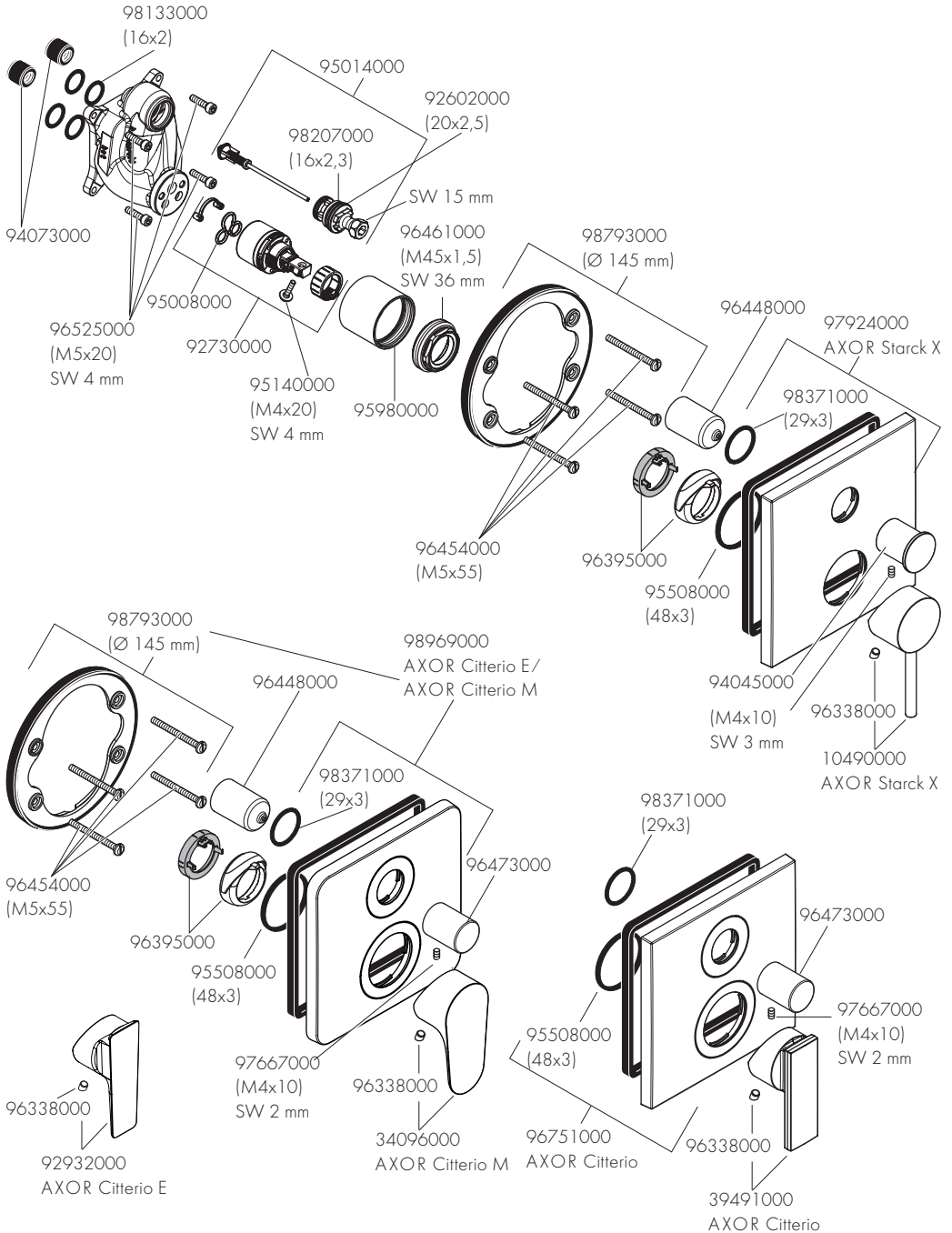



- DE / Reinigungsempfehlung / Garantie / Kontakt
FR / Recommandation pour le nettoyage / Garanties / Contact
EN / Cleaning recommendation / Warranty / Contact
IT / Raccomandazione di pulizia / Garanzia / Contatto
ES / Recomendaciones para la limpieza / Garantía / Contacto
NL / Aanbevelingen inzake reiniging / Garantie / Contact
DK / Rensning, anbefaling / Garanti / Kontakt
PT / Recomendações de limpeza / Garantia / Contacto
PL / Zalecenie dotyczące pielęgnacji / Gwarancja / Kontakt
CS / Doporučení k čištění / Záruka / Kontakt
SK / Odporúčania pre čistenie / Záruka / Kontakt
ZH / 清洁指南 / 担保 / 接触
RU / Рекомендации по очистке / Гарантия / Контакты
HU / Tisztítási tanácsok / Garancia / érintkezés
FI / Puhdistussuositus / Takuu / Kosketus
SV / Rengöringsrekommendationer / Garanti / Contacto
LT / Valymo rekomendacijos / Garantija / Kontaktai
HR / Preporuke za čišćenje / Garancija / Kontakt
TR / Temizleme önerisi / Garanti / Temas
RO / Recomandări pentru curățare / Garanție / Contact
EL / Σύσταση καθαρισμού / Εγγύηση / επαφή
SL / Priporočilo za čiščenje / Garancija / Kontakt
ET / Puhastussuovitused / Garantii / Kontakt
LV / Tīrīšanas ieteikumi / Garantija / Kontakti
SR / Preporuke za čišćenje / Garancija / Kontakt
NO / Anbefaling for rengjøring / Garanti / Kontakt
BG / Препоръка за почистване / Гаранция / Контакт
SQ / Këshilla rreth pastrimit / Garancia / Kontakt
KO / 세정시 권장사항 / 품질보증 / 접촉
AR / توصيات التنظيف / الضمان (الولايات المتحدة الأمريكية) / اتصال



[www.axor-design.com/
cleaning-recommendation](http://www.axor-design.com/cleaning-recommendation)

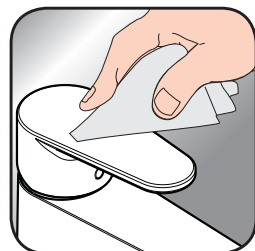

[www.axor-design.com/
cleaning-recommendation](http://www.axor-design.com/cleaning-recommendation)









[www.axor-design.com/
cleaning-recommendation](http://www.axor-design.com/cleaning-recommendation)



[www.axor-design.com/
cleaning-recommendation](http://www.axor-design.com/cleaning-recommendation)



	P-IX	DVGW	SVGW	ACS	WRAS	KIWA		ETA
10414000				X			1392	
10416XXX	PA-IX 9709/ICC	CQ0125	X	X	X	X	1392	 1.42/18751
10445000	PA-IX 9709/ICC	CQ0125	X	X	X	X	1392	 1.42/18751
34425000	PA-IX 9709/ICC	CQ0125	X	X	X		1392	 1.42/18751
36455000				X			1392	
38425000	PA-IX 9709/ICC	CQ0125	X	X	X	X	1392	 1.42/18751
39455000	PA-IX 9709/ICC	CQ0125	X	X	X	X	1392	 1.42/18751



AXOR

AXOR / Hansgrohe SE
Austraße 5-9
77761 Schiltach
Deutschland

info@axor-design.com
axor-design.com

01/2018
9.09451.12