

Mamba

high basin faucet

Wellis®

ACS0269

※ACCESSORIES CHECKING

LIST OF THE STANDARD ACCESSORIES:

Please double-check the accessory list hereinafter and contact our company or our distributor for any unconformity.

Remarks:

1. Without affecting their performing, accessories may be changed without further notice;
2. Drawings for reference only, Product size & shape refer to actual faucet.

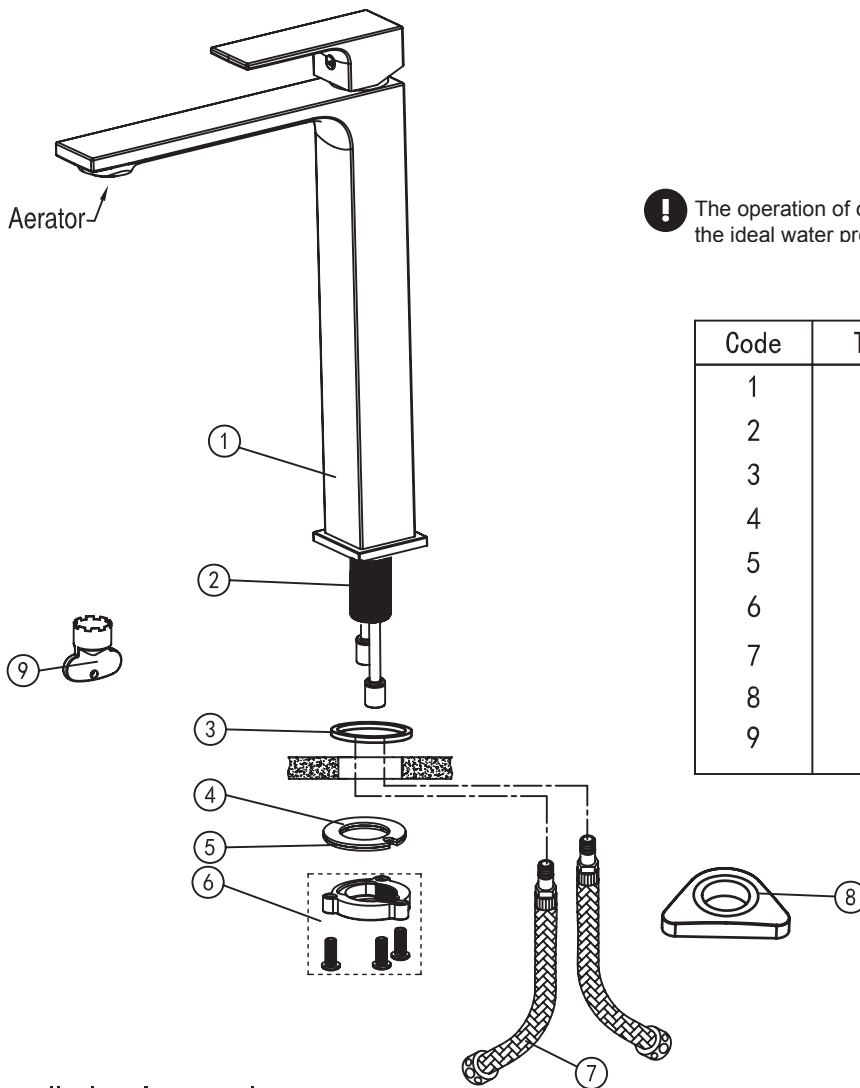

Code	The Accessory List	Quantity
1	Main body	1
2	Threaded sleeve	1
3	O-ring	1
4	Rubber washer	1
5	Clamp	1
6	Fixed nut	1
7	Inlet pipe	2
8	Base	1
9	Aerator wrench	1

※Installation Instructions

- ☆ Do not disassemble the main body, as it has been installed & commissioned correctly & precisely before leaving the factory;
- ☆ To avoid the faucet from jamming, do flush the water pipe before installation;
- ☆ After installation, make sure every joint is safely sealed & no leaking;
- ☆ Using condition: Working pressure at 0.05-1.0MPa (including cold & hot water pressure), with applicable water temperature: 4°C-90°C;
- ☆ Make sure to connect the hot/cold inlet pipe correctly, if standing in front, hot water pipe connecting to the left & cold water pipe connecting to the right.

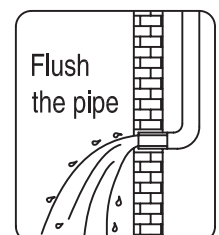
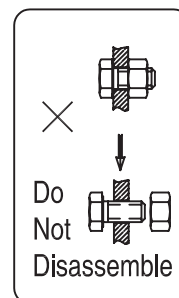

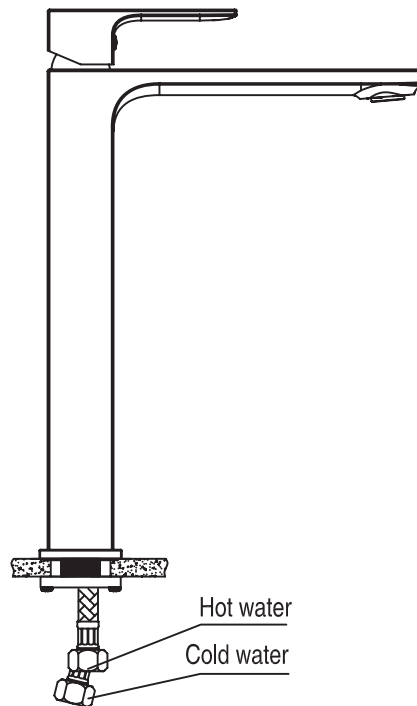
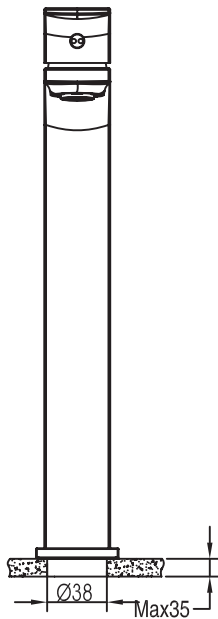

※Installation Procedures

- ☆ Make sure the installation holes to be in right size;
- ☆ Connect the main body & water supply pipe with water inlet pipe.

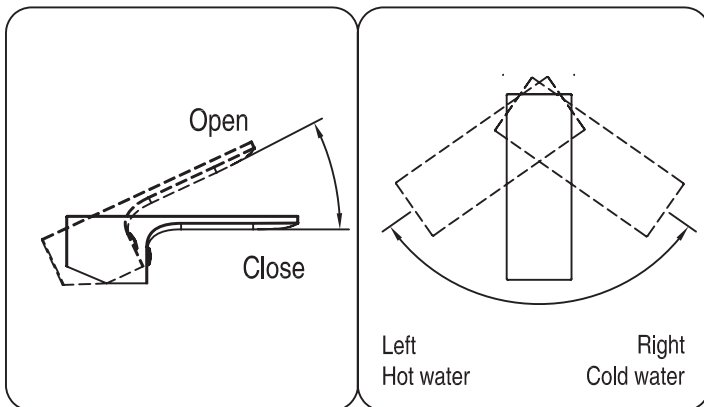

※Usage

☆How to operate the handle

1. Raise the handle up for opening water; push it down for close;
2. Turn the handle to the left to increase hot water flow for higher water temperature, and lower water temperature by operating reversely.
3. The swivelling can be circled 360°.

※Cleaning & Maintenance

☆ To keep the product clean & shining, follow the as below:

1. Flush with clean water & dry with soft cloth only;
2. If any dirt, clean with soft liquid or transparent glass detergent;
3. Do not use any scrubbing detergent, polisher, sane-cloth, paper tissue or scraper;
4. Do not use acid detergent, indissolvable grain-like detergent or soap;
5. Disassemble the aerator with a coin and clean it when necessary.

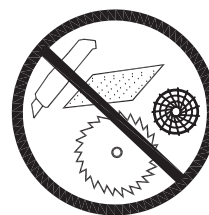

Mamba

magas mosdó csaptelep

Wellis®

ACS0269

Alkatrészek ellenőrzése

Standard alkatrészelista

Kérjük, ellenőrizze az alkatrészelistát és lépjen kapcsolatba vállalatunkkal és forgalmazónkkal, ha bármilyen rendellenességet tapasztal!

Megjegyzés:

1. Az alkatrészeket, funkciót nem érintő változások esetén értesítés nélkül módosíthatjuk.
2. A rajzok csak referenciaként szolgálnak. A termékek mérete és alakja kapcsán nézze meg az aktuális vízcsapot!

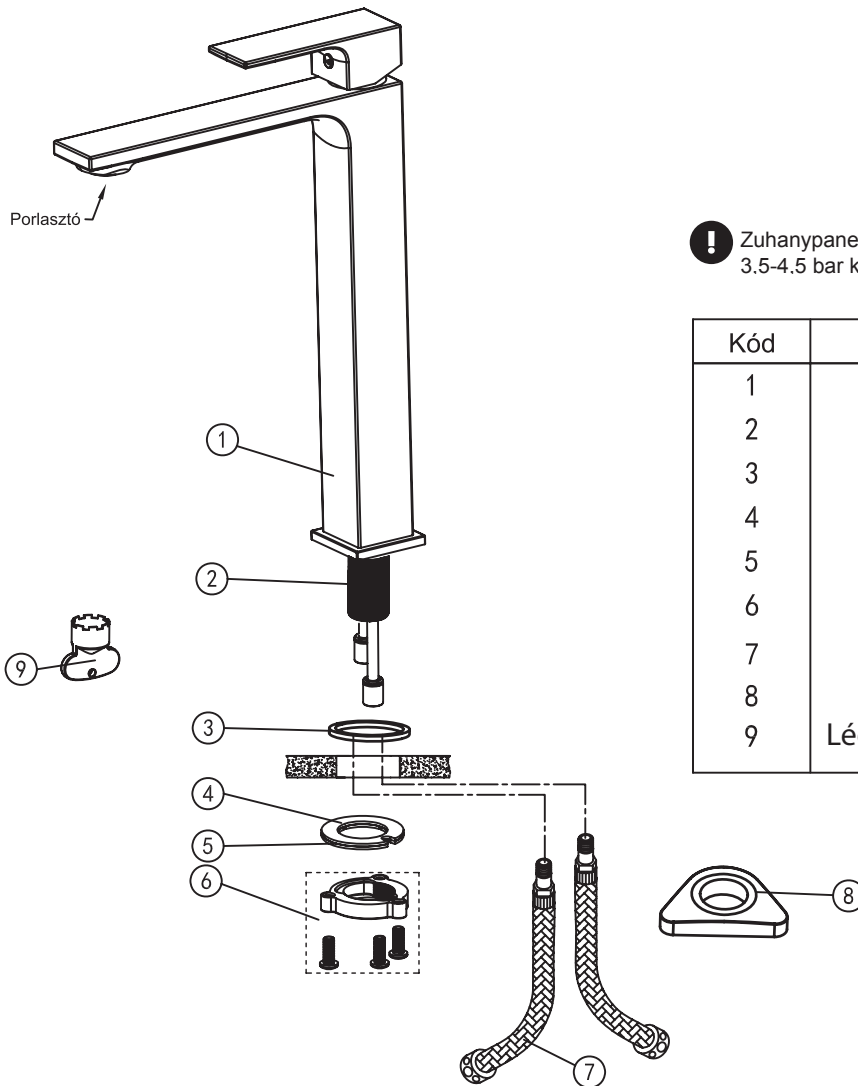

! Zuhanypaneljeink és csaptelepeink működése az ideális 3.5-4.5 bar közötti víznomásra van tervezve.

Kód	Alkatrészelista	Mennyiség
1	Főtest	1
2	Menetes hüvely	1
3	Gumitömítés	1
4	Gumi alátét	1
5	Szorító	1
6	Rögzítő anya	1
7	Bemeneti cső	2
8	Alap elem	1
9	Légtelenítő csavarkulcs	1

Szerelési Útmutató

- Ne szerelje szét az alaptestet, mert az a gyártás során lett pontosan összeszerelve és hitelesítve!
- Annak érdekében, hogy elkerülje a csaptelep működési problémáit, szerelés előtt folyassa át alaposan vízzel a vízvezeték rendszert!
- Szerelés után győződjön meg arról, hogy mindegyik csatlakozás a tömítés jó és nincs szivárgás!
- Használati feltétel: 0.05-1.0 MPa üzemi nyomás (mind hideg és meleg víz esetén) és 4 °C- 90 °C víz hőmérséklet
- Győződjön meg arról, hogy a hideg és melegvíz bevezető csövet megfelelően csatlakoztassa! Ha szemben áll a csapteleppel, akkor a melegvíz-csövet a bal és a hidegvízcsövet a jobb oldalon csatlakoztassa!

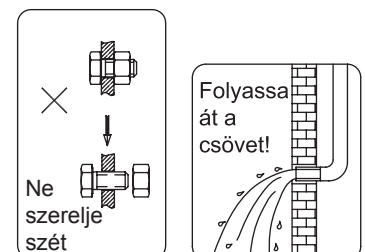

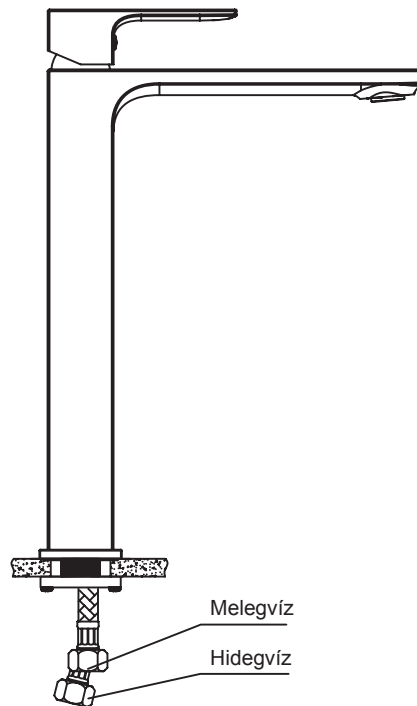
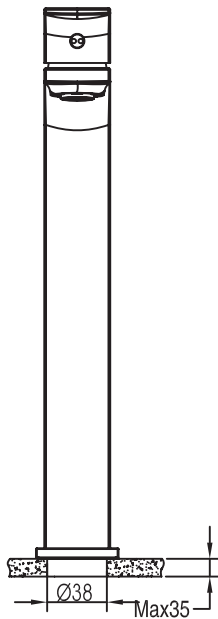

Szerelési eljárás

Győződjön meg arról, hogy a szerelési lyukak megfelelő méretűek!
Csatlakoztassa az alaptestet és a vízvezetékcsövet a bevezető vízvezetékcsővel!

Használat

Hogyan használja a forgatókart?

1. A csap megnyitásához emelje felfelé, az elzáráshoz nyomja lefelé a kart!
2. A kifolyó víz hőmérsékletének növeléséhez forgassa balra, míg a víz hőmérséklet csökkentéséhez forgassa jobbra a kart!

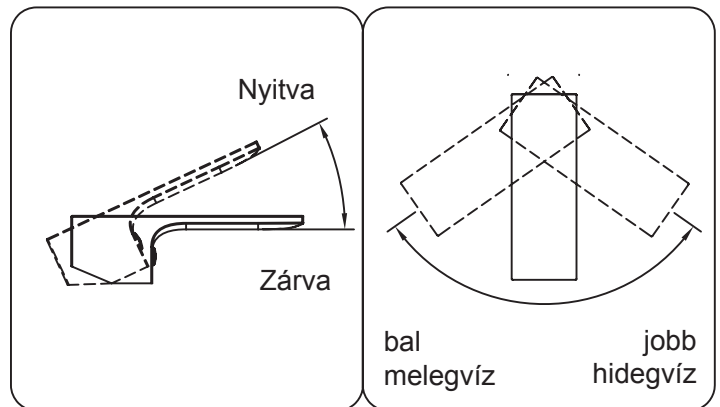

Tisztítás és karbantartás

Kövesse az alábbi útmutatásokat annak érdekében, hogy a termék tiszta és csillogó legyen!

1. Folyassa át tiszta vízzel és csak puha ronggyal törölje szárazra!
2. A szennyeződéseket gyenge folyékony tisztítószerrel vagy ablaktisztítóval távolítsa el!
3. Ne használjon mosószeret, polírozót, nedvszívó rongyot, papírtöröltőt vagy kaparó eszközt!
4. Ne használjon savas mosószeret, oldhatatlan szemcsés szerkezetű mosószeret vagy szappant!
5. Csavarja le a porlasztót és tisztítsa meg, ha szükséges!



Mamba

baterie chiuvetă înaltă

ACS0269

Verificarea pieselor

Listă de piese standard

Vă rugăm să verificați lista de piese și să luați legătura cu societatea noastră și distribuitorul nostru în cazul în care constatați probleme!

Notă:

1. Modificările care nu afectează piesele și funcționarea pot fi realizate fără o notificare prealabilă.
2. Schițele au doar rol de referință. Pentru dimensiunea și forma produselor consultați bateria propriu-zisă!

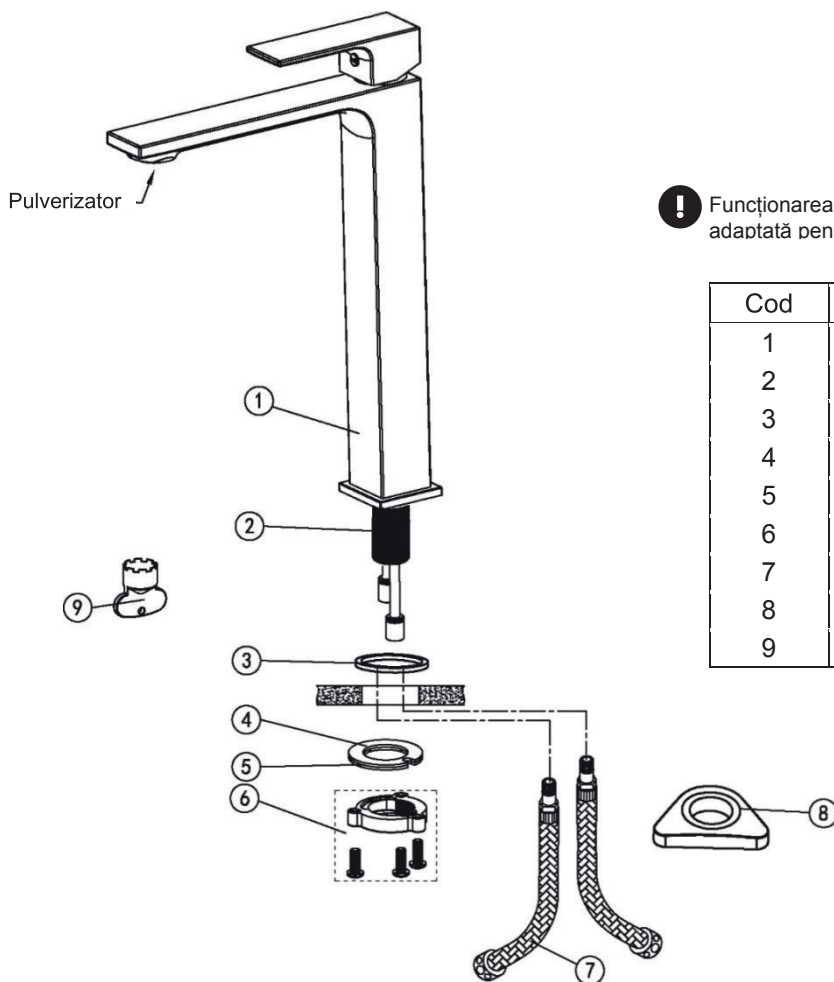

! Funcționarea ansamblurilor și a robinetelor noastre de duș este adaptată pentru o presiune ideală a apei de 3.5-4.5 bari.

Cod	Listă de piese	Cantitate
1	Corp principal	1
2	Manșon filetat	1
3	Garnitură din cauciuc	1
4	Șaibă din cauciuc	1
5	Piesă de fixare	1
6	Piuliță de fixare	1
7	Țeavă intrare	2
8	Element de bază	1
9	Cheie de aerisire	1

Instrucțiuni de montare

- Nu demontați corpul de bază, acesta a fost asamblat și certificat în etapele de producție!
- Pentru a evita problemele de funcționare ale bateriei, spălați bine cu apă sistemul de conducte înainte de montare!
- După instalare, asigurați-vă că toate garniturile de la toate racordurile sunt bune și nu există scurgeri!
- Condiții de utilizare: Presiune de funcționare 0,05-1,0 MPa (pentru apă caldă și apă rece) și temperatura apei de 4 °C - 90 °C
- Asigurați-vă că ați conectat corespunzător conducta de apă caldă și rece! Dacă stați cu fața la baterie, conducta de apă caldă se leagă pe partea stângă, iar apa rece la partea dreaptă!

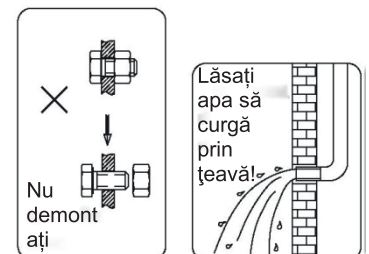

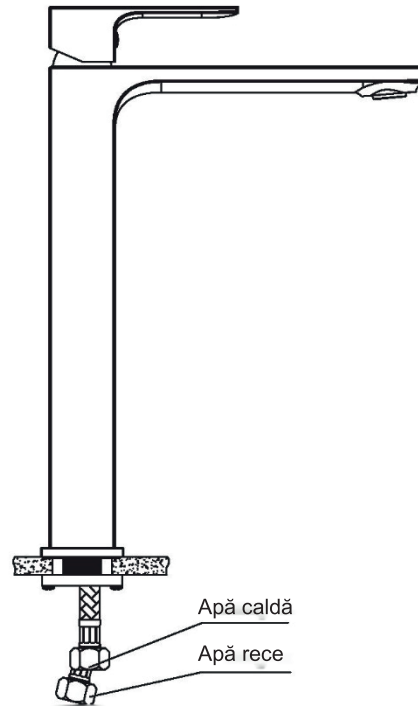
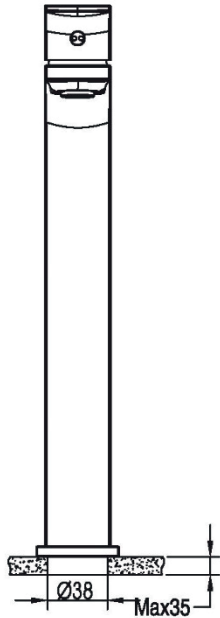

Instalarea

Asigurați-vă că orificiile de montare au dimensiunea corespunzătoare!
 Racordați corpul de bază și conducta de apă cu furtunul de alimentare!

Utilizare

Cum se utilizează brațul?

1. Pentru deschiderea robinetului ridicăți, pentru a închide, apăsați în jos!
2. Pentru creșterea temperaturii apei rotiți brațul spre stânga, pentru reducerea temperaturii rotiți spre dreapta!

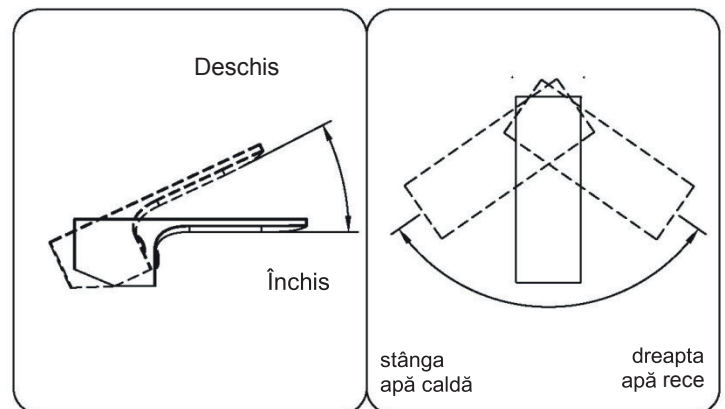

Curățare și întreținere

Respectați instrucțiunile de mai jos pentru ca produsul să fie curat și strălucitor!

1. Lăsați apa să curgă prin instalație apoi ștergeți cu o lavetă moale!
2. Îndepărtați murdăria cu agent de curățare lichid sau soluție pentru spălat geamuri!
3. Nu folosiți detergent, substanțe de șlefuit, lavetă absorbantă, șervețele de hârtie sau scule care zgârie!
4. Nu folosiți detergenți acizi, detergent cu granule care nu se dizolvă sau săpun!
5. Deșurubați pulverizatorul și curățați-l, dacă este necesar!

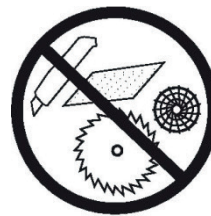

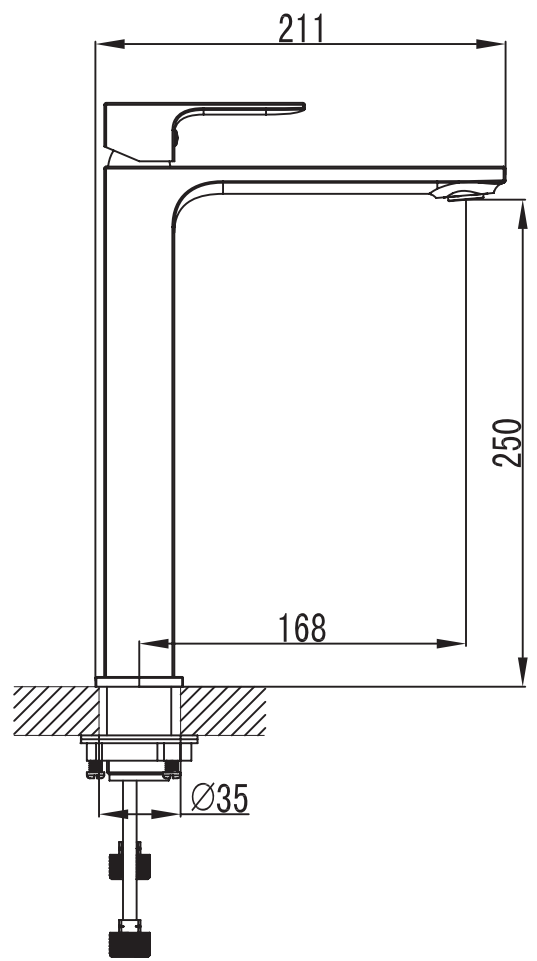
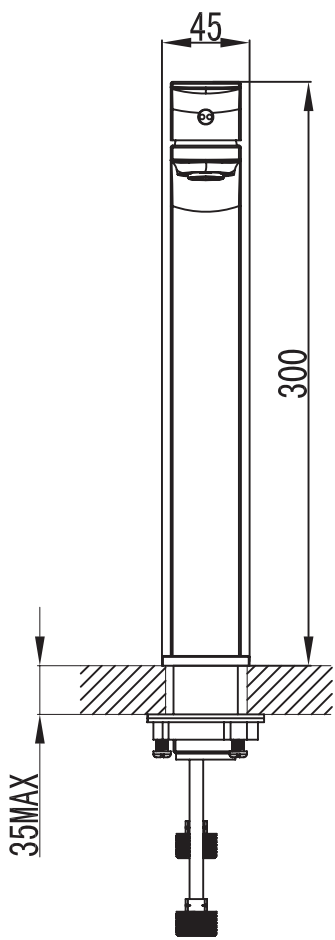

Wellis®