

- | | | | |
|------------|-------------------------|-----------|-----------------------------|
| PL | Instrukcja montażu | UA | Інструкція по установці |
| GB | Assembly instruction | H | Szerelési útmutató |
| D | Montageanleitung | RO | Instructiuni de montaj |
| SK | Návod na inštaláciu | FR | Instruction de montage |
| CZ | Pokyny k instalaci | IT | Istruzioni di montaggio |
| RUS | Инструкция по установке | ES | Instrucciones de ensamblaje |
| | | AE | تعليمات التجميع |

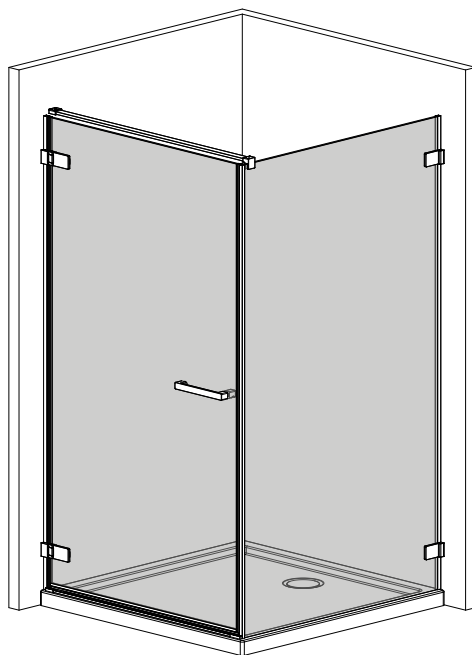

Arta KDJ I

- | | |
|------------|--|
| PL | Instrukcja pokazuje montaż kabiny w wariacie lewym |
| GB | Assembling instruction shows installation of left-side version |
| D | Die Montageanleitung stellt die linke Variante der Dusche dar |
| SK | Návod na inštaláciu sa vzťahuje na ľavé prevedenie |
| CZ | Návod zobrazuje instalaci sprchového koutu vlevo |
| RUS | В инструкции указан монтаж левого варианта кабины |
| UA | В інструкції вказаний монтаж лівого варіанту kabini |
| RO | Instructiunile de montaj se refera la instalarea cu deschidere pe stanga |
| H | A szerelési útmutató balos verzióra vonatkozik |
| FR | L'instruction montre un montage en version gauche |
| IT | Le istruzioni di montaggio mostrano l'installazione della versione sinistra |
| ES | La instrucción de montaje muestra la instalación de laversion del lado izquierdo |
| AE | يوضح تجميع التعليمات التثبيت من نسخة الجانب الأيسر |

Beépítési tudnivalók

2+1ÉV**GARANCIA**

Beépítéshez javasoljuk megnövelt (2+1 év) garanciával a saját márkaszervizünket, az ország egész területén.

Beszerezés megrendelés: szerviz@metahungary.hu | radaway.hu

A Radaway márkaszervizünk garantálja:

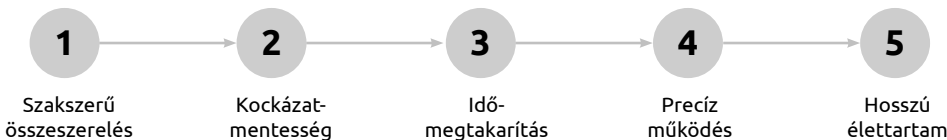

Mielőtt saját kezűleg kezd hozzá a beépítéshez, ezt mindenképp tudnia kell!

1. Beépítés előtt kérjük, ellenőrizze a termék minőségét, hogy nincs-e a terméknek hibája, nem sérült-e a szállítás során.
2. Feltétlenül ellenőrizze le, hogy az áru megjelenése, méretei és színe (cikkszám) megfelel-e az Ön megrendelésének.
3. Beépítés után a gyártó csak a gyártási és az anyaghibákra ismeri el a garanciát. A már beszerelt terméken észlelt hibákért nem vállalunk felelősséget. Annak plusz költségeit nem áll módunkban átvállalni.
4. A terméket kizárólag rendeltetésszerűen lehet használni, ellenkező esetben a garanciális jog elvész.
5. A beszerelt terméket a szilikonos tömítés után 24 órával lehet csak használni.
6. A szerkezeti változtatás jogát fenntartjuk.
7. Ajánlás: A termék beszereléséhez két ember szükséges.

A zuhanykabinra és zuhanytálcára alap esetben 2 év jótállást vállalunk.

A jótállási idő a számla kiállításának napjával indul. Garanciális igényeit közvetlenül nálunk, márkaszervizünkhöz fordulva is érvényesítheti.

A garanciális igény érvényesíthetőségének egyik feltétele, hogy a termék szakszerűen, jelen szerelési útmutató szerint kerüljön üzembe helyezésre, beépítésre. A nem szakszerűen beépített vagy rögzített termékre a garancia nem terjed ki, annak javítása, ill. cseréje során a bontási és helyreállítási költségek, valamint a kiszállás díja a vevőt terheli. Üvegtörés esetén a garanciális feltételek nem érvényesíthetőek.





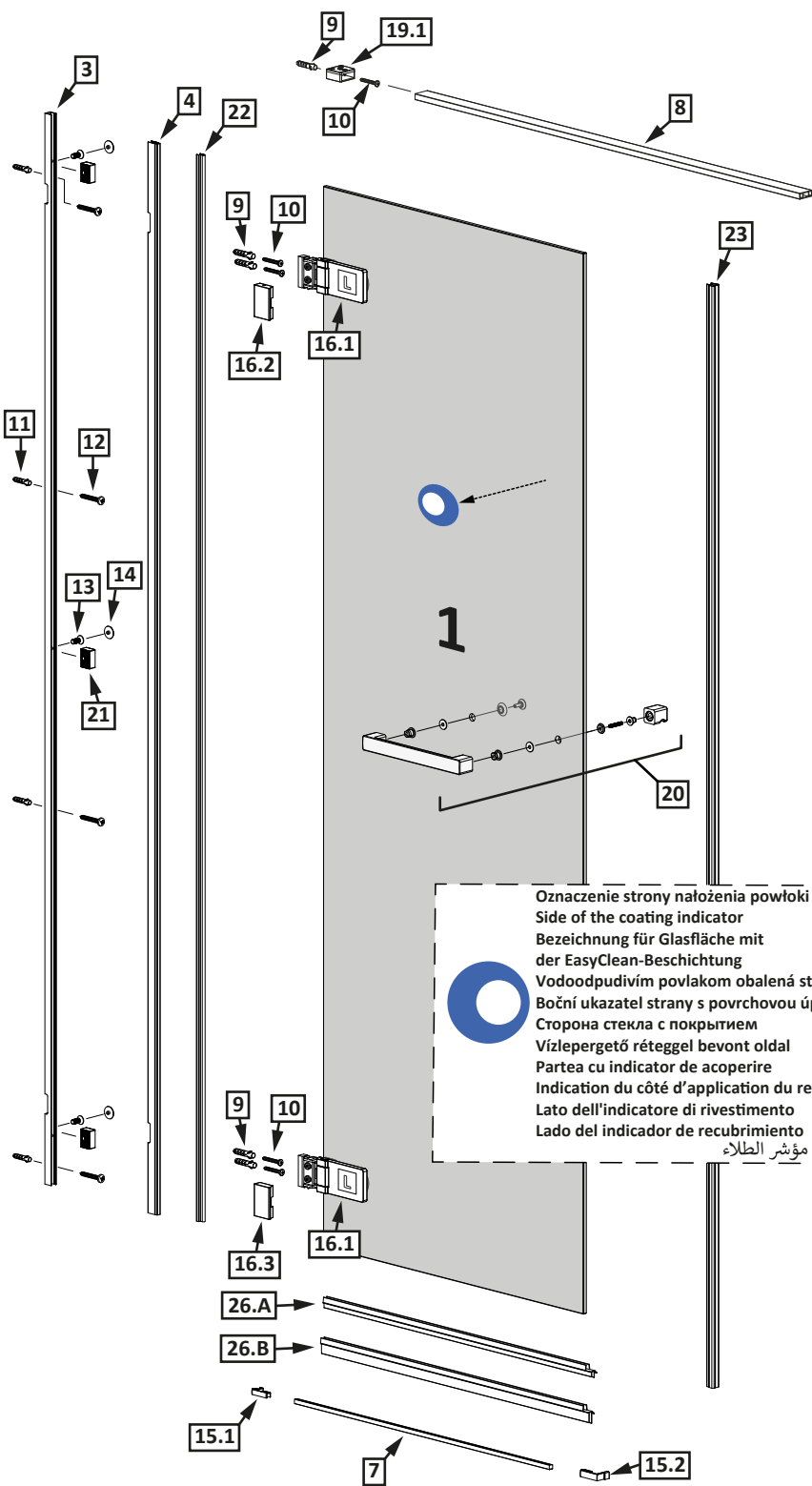



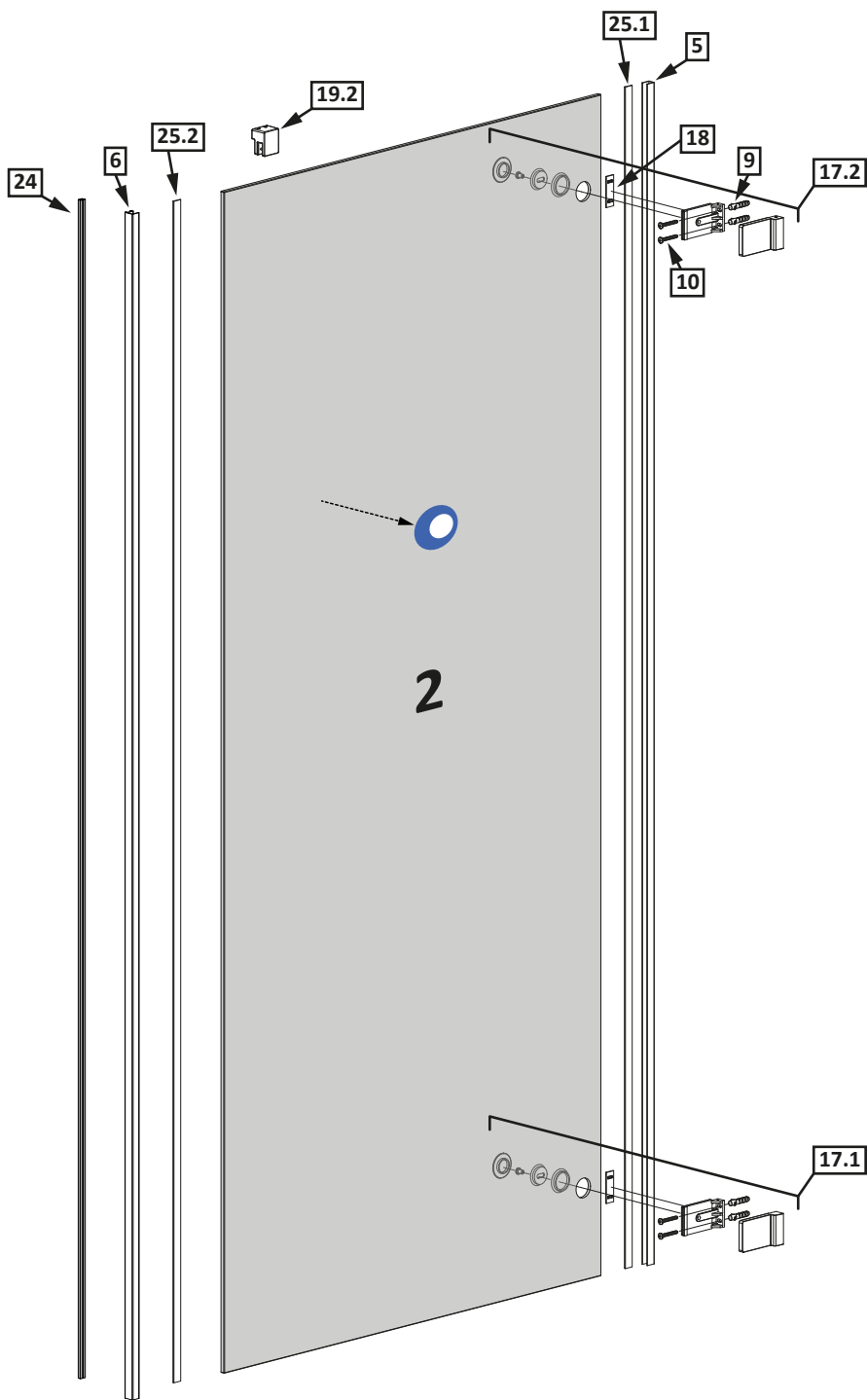

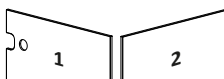









A Radaway márkaszerviz igénybevétele esetén a megnövekedett jótállási idő 2+1 év!

A jótállás részletes feltételeit a jótállási jegy tartalmazza.

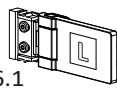

















Oznacenie strany nalozenia povtlaki
 Side of the coating indicator
 Bezeichnung für Glasfläche mit
 der EasyClean-Beschichtung
 Vodoodpudivím povtlakom obalená strana
 Boční ukazatel strany s povrchovou úpravou
 Сторона стекла с покрытием
 Vízlepergető réteggel bevont oldal
 Partea cu indicator de acoperire
 Indication du côté d'application du revêtement
 Lato dell'indicatore di rivestimento
 Lado del indicador de recubrimiento
 جانب من مؤشر الطلاء



Nr Nr No. číslo počet № Sorszám Numar N° N° N° رقم	Oznaczenie Mark Bezeichnung Označení Označení обозначение Jelölés Componenta Symbole Simbolo Símbolo علامة	Sztuk Pcs. Stück Kus KS штук Db. Bucati Pcs Pz Pzas قطع
1. 2.		1 1
3.		1
4.		1
5.		1
6.		1
7.		1
8.		1
9.	 $\phi 8$ DIN 7981	9
10.	 5x40 DIN 7991	9
11.	 $\phi 6$ DIN 7981	4
12.	 3,5x25 DIN 7991	4
13.		3
14.		3
15.1 15.2	 15.1  15.2	1 1
16.1 16.2 16.3	 16.1  16.2  16.3	2 1 1
17.1 17.2	 17.1  17.2	1 1
18.		2

Montaż z listwą progową
Installation with threshold profile
Die Montage mit Schwalleiste
Montovanie s prahovým profilom
Instalace přechodové lišty
Монтаж с профилем порога
Szerelés küszöb profilal
Instalarea cu profil prag
Montage avec barre de seuil
Installazione con profilo di soglia
Instalación con la barra de umbral
تجميع مع شريط عتبة

Montaż bez listwy progowej
Installation without threshold profile
Die Montage ohne Schwalleiste
Montovanie bez prahového profilu
Instalace bez prahové lišty
Монтаж без профиля порога
Szerelés küszöb profil nélkül
Instalarea fara profil prag
Montage sans barre de seuil
Installazione senza profilo di soglia
Instalación sin la barra de umbral
تجميع دون شريط عتبة

Nr Nr No. číslo počet № Sorszám Numar N° N° N° رقم	Oznaczenie Mark Bezeichnung Označenje Označení обозначение Jelölés Componenta Symbole Simbolo Símbolo علامة	Sztuk Pcs. Stück Kus KS штук Db. Bucati Pcs Pz Pzas قطع
19.1 19.2	19.1  19.2 	1 1
20.		1
21.		3
22.		1
23.		1
24.		1
25.1 25.2	25.1  25.2 	1 1
26.A		1
26.B		1
27.		1
28.		1
29.		2
30.	 1mm 2mm 3mm 4mm 5mm	4
31.	 +  1mm 1mm 1mm	2

Montaż z listwą progową
Installation with threshold profile
Die Montage mit Schwallleiste
Montovanie s prahovým profilom
Instalace přechodové lišty
Монтаж с профилем порога
Szerelés küszöb profilal
Instalarea cu profil prag
Montage avec barre de seuil
Installazione con profilo di soglia
Instalación con la barra de umbral
تجميع مع شريط عتبة

Montaż bez listwy progowej
Installation without threshold profile
Die Montage ohne Schwallleiste
Montovanie bez prahového profilu
Instalace bez prahové lišty
Монтаж без профиля порога
Szerelés küszöb profil nélkül
Instalarea fara profil prag
Montage sans barre de seuil
Installazione senza profilo di soglia
Instalación sin la barra de umbral
تجميع دون شريط عتبة

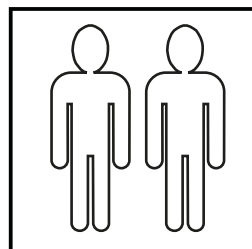
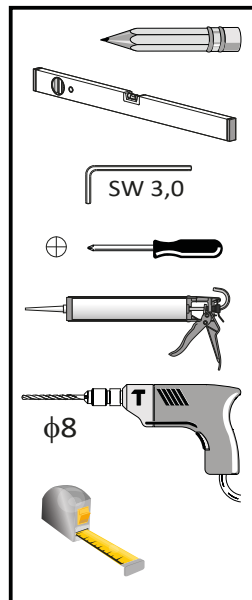

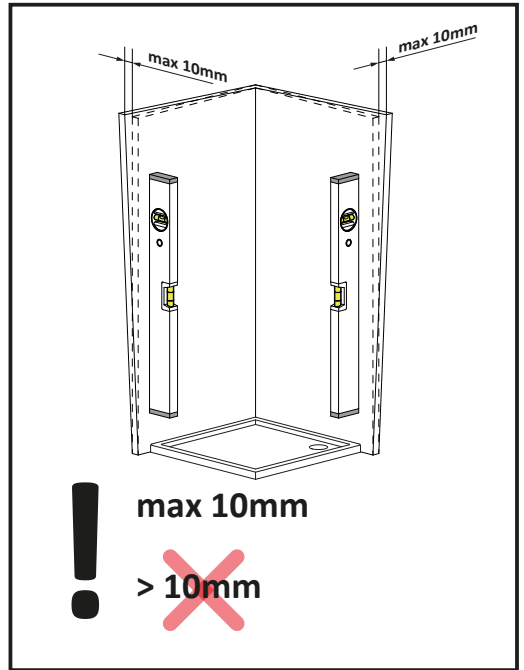
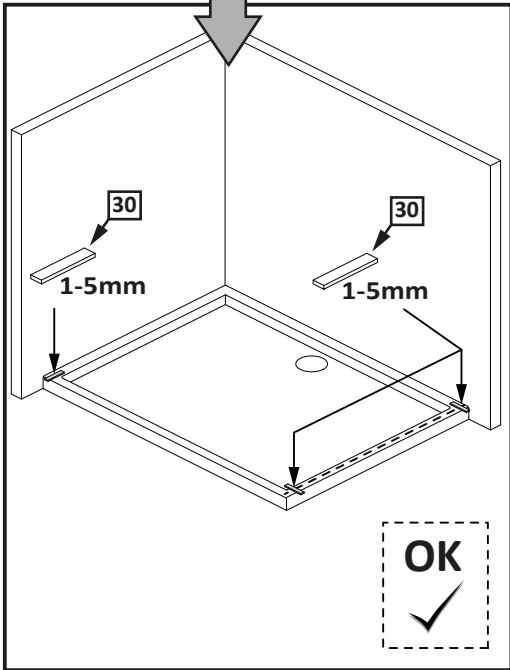
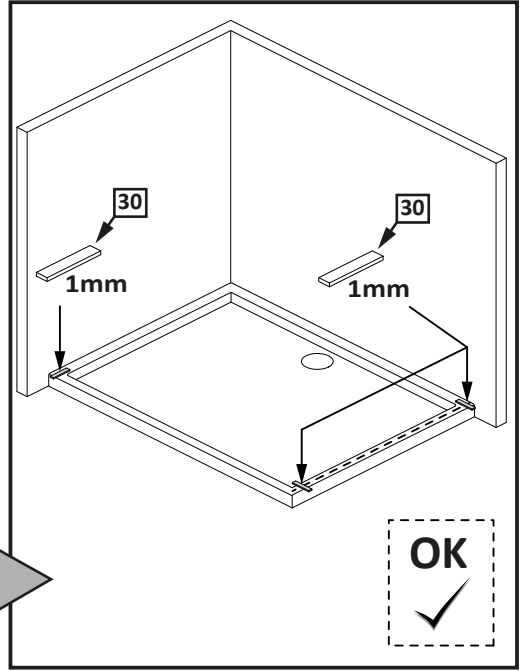
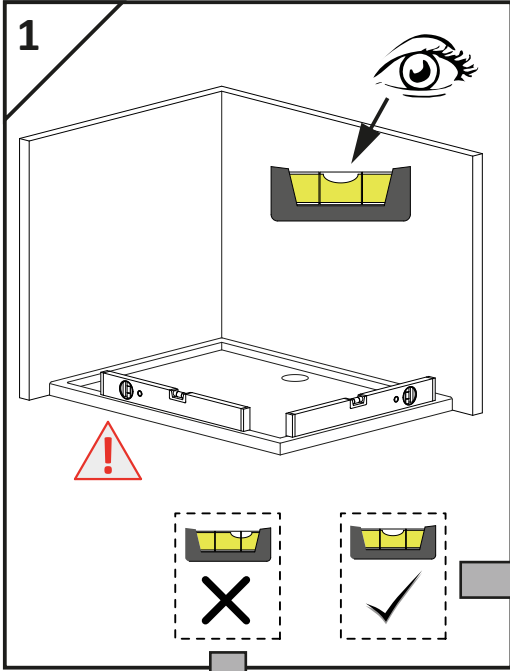

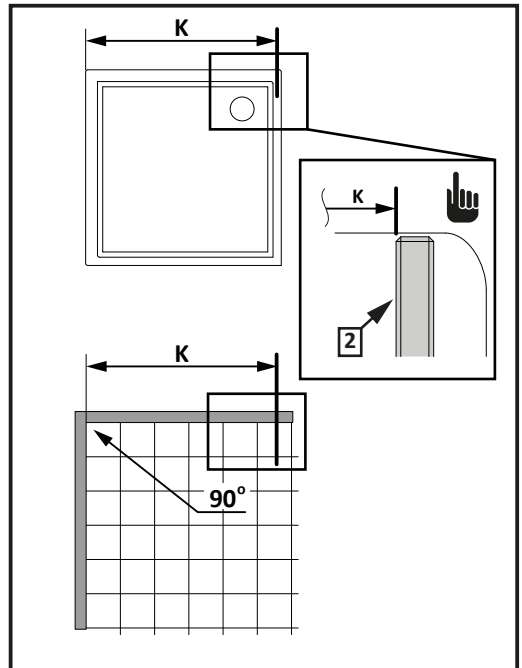
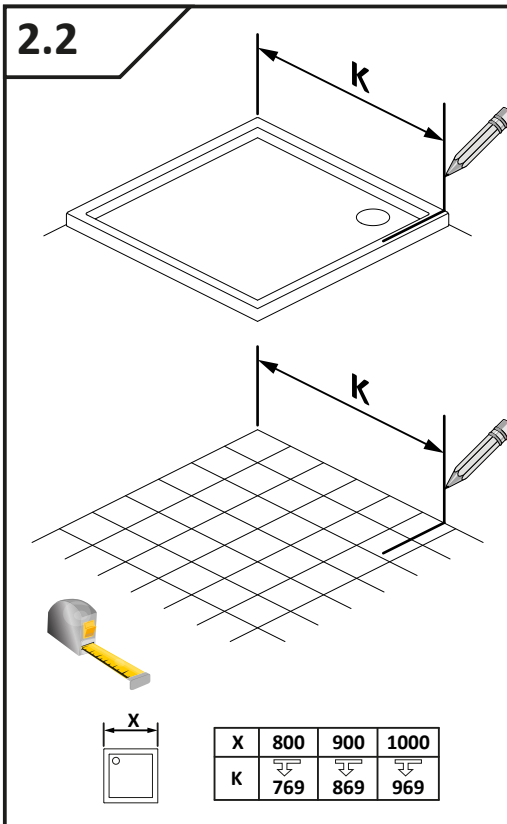
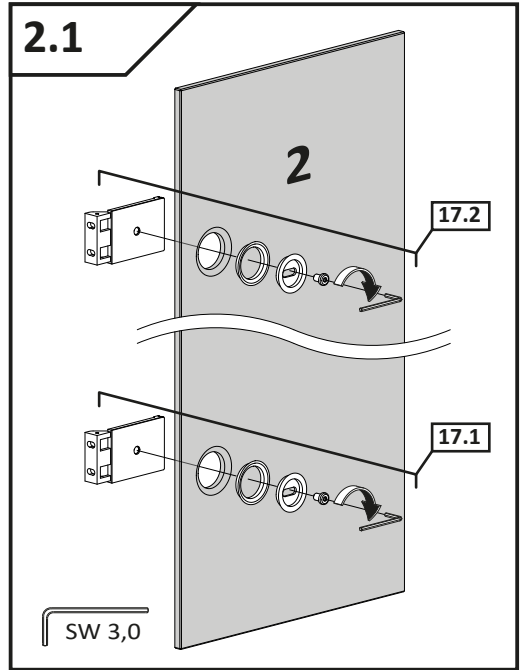
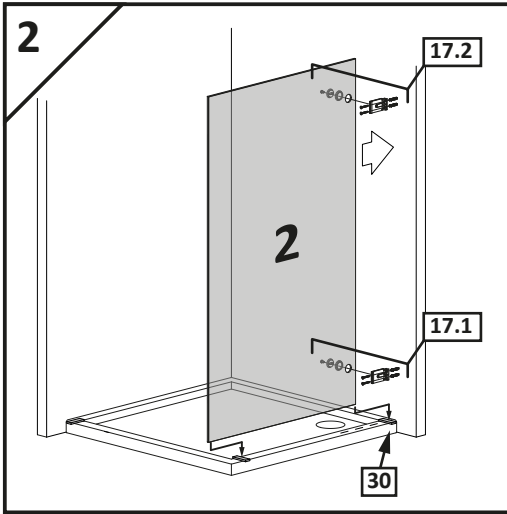

2.3

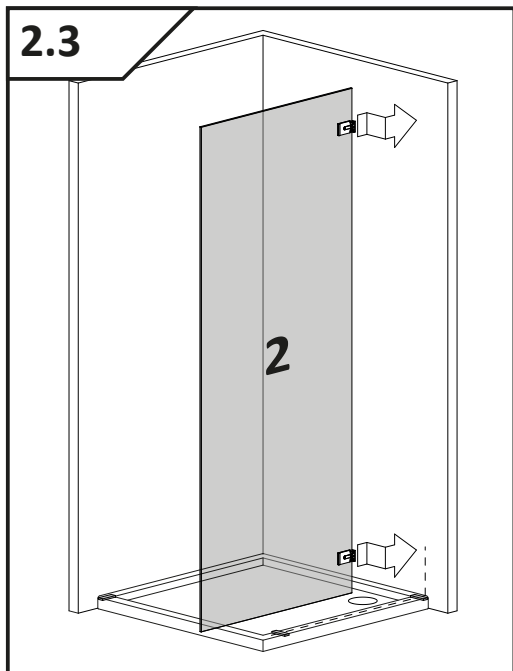

2.4

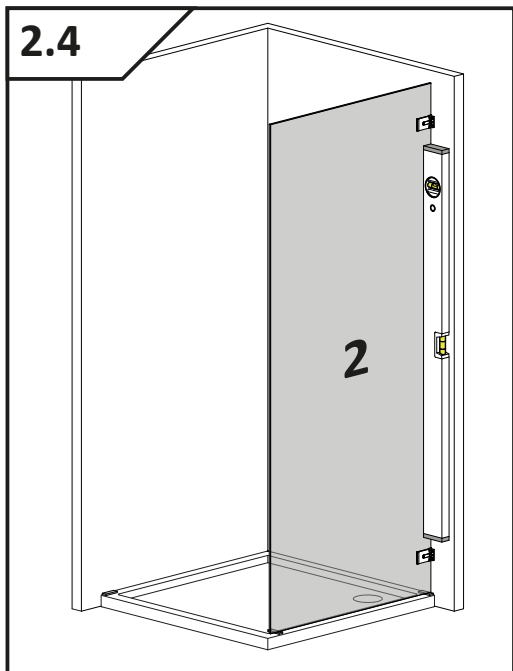

2.5

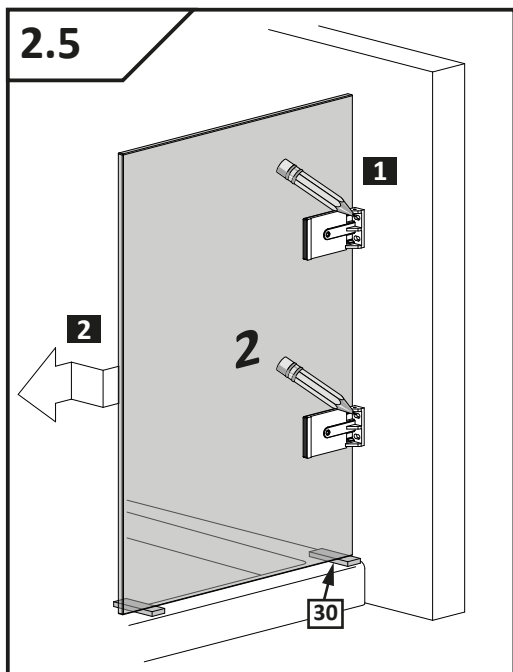

2.6

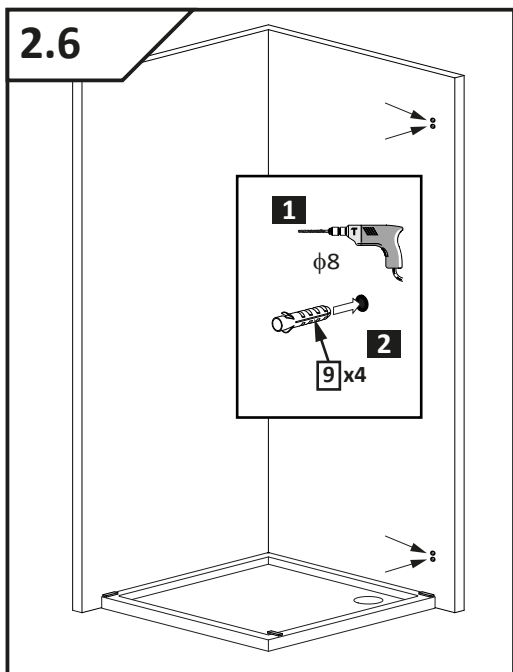

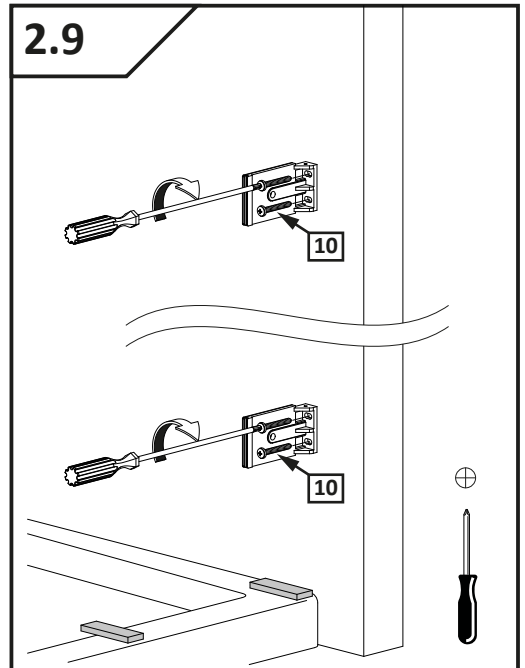
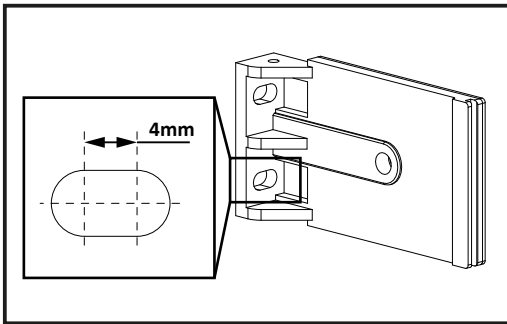
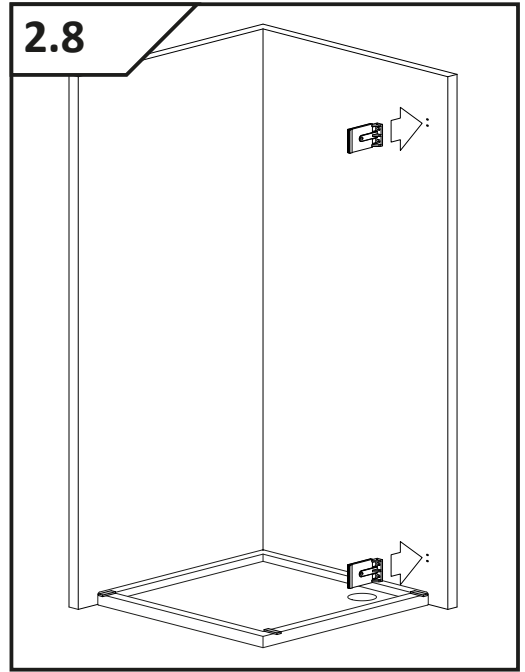
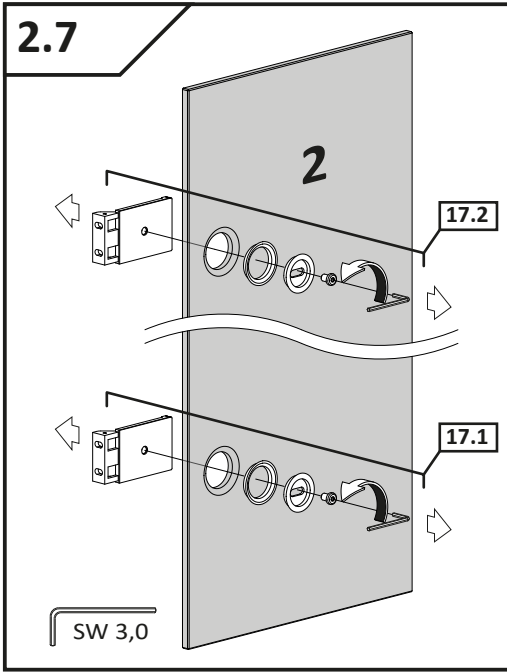

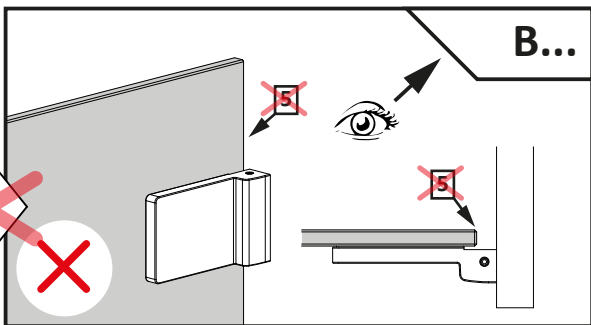
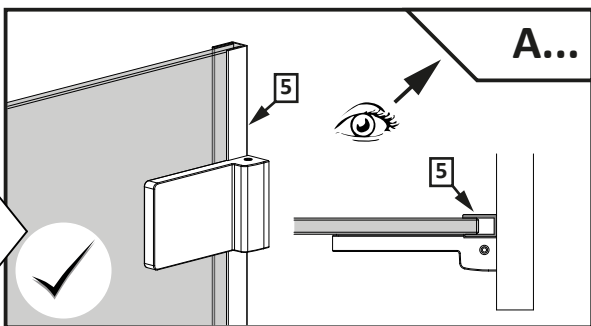
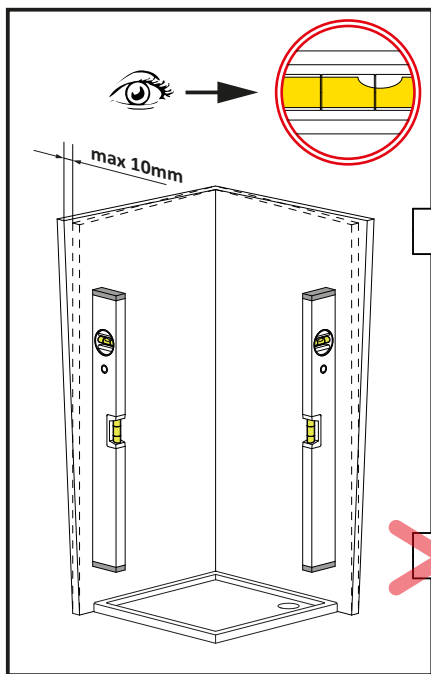
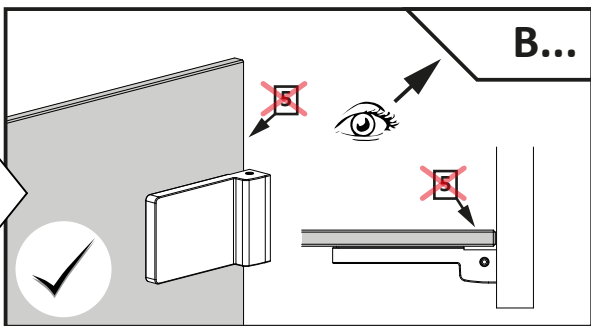
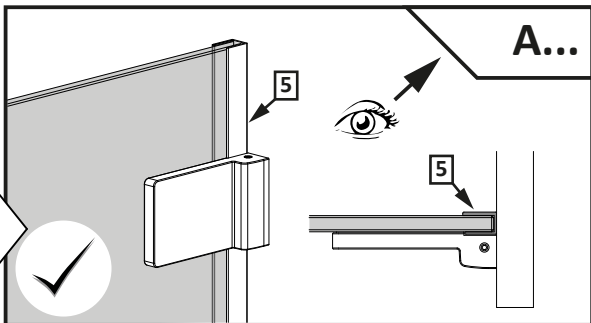
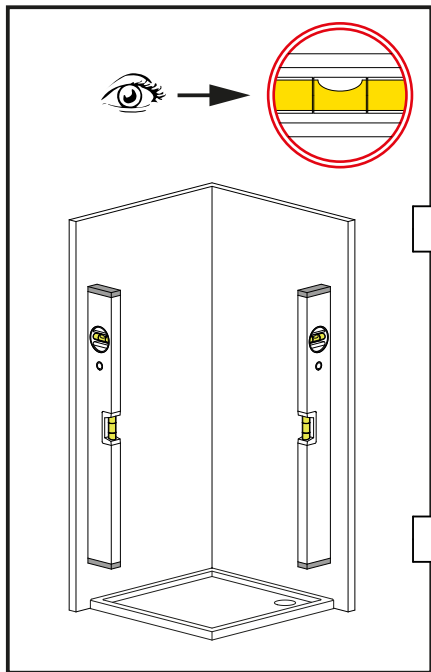

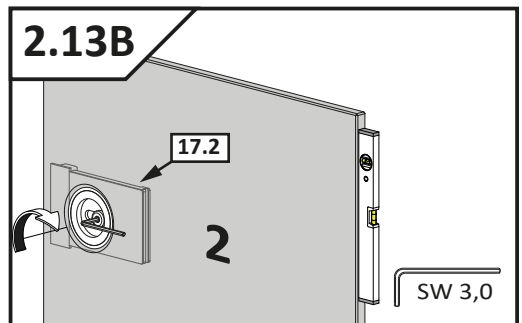
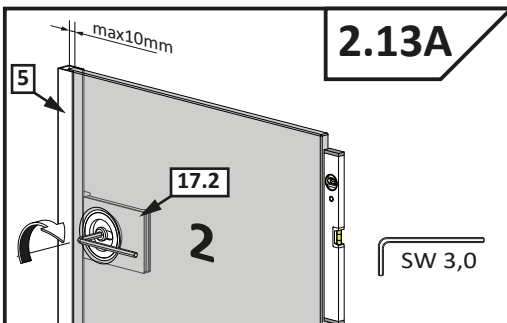
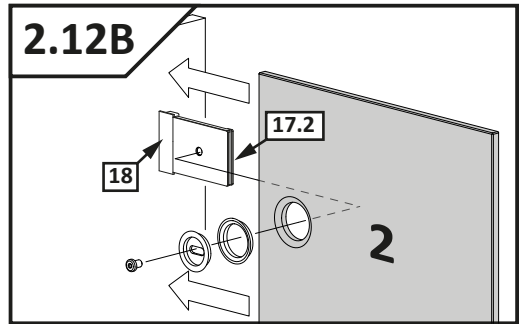
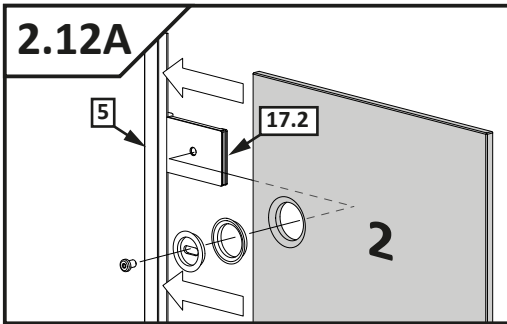
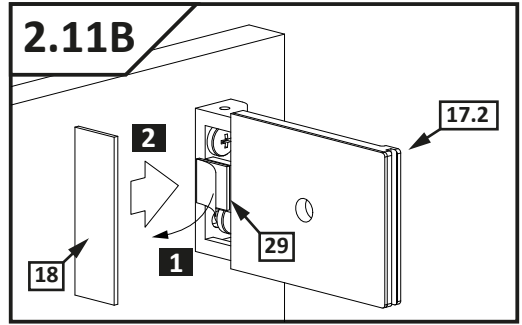
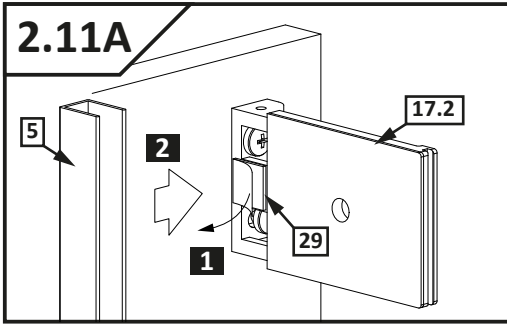
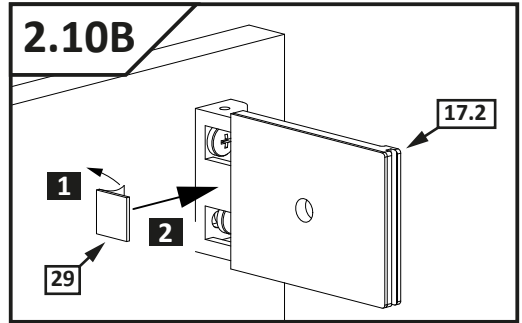
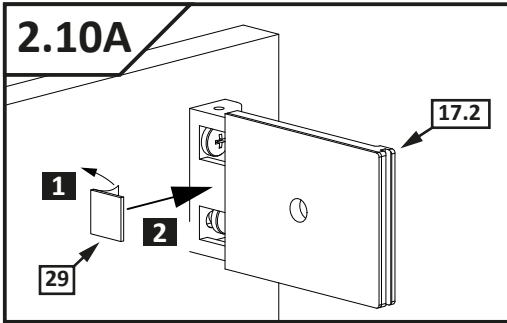

2.14

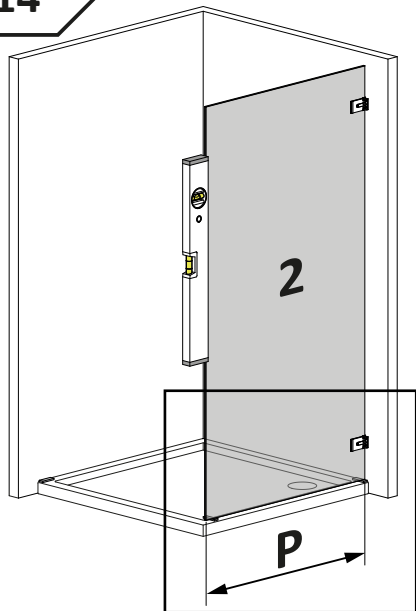

Y	700	750	800	900	1000	1100	1200
~P	679	729	779	879	979	1079	1179

3

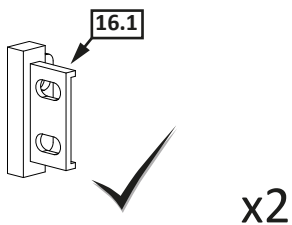
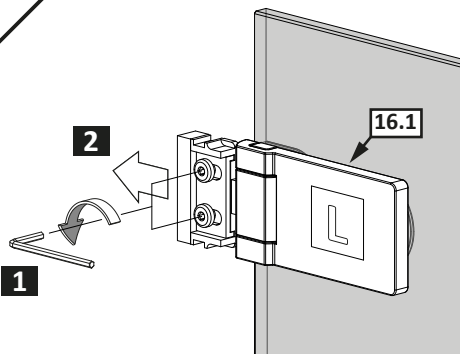

4

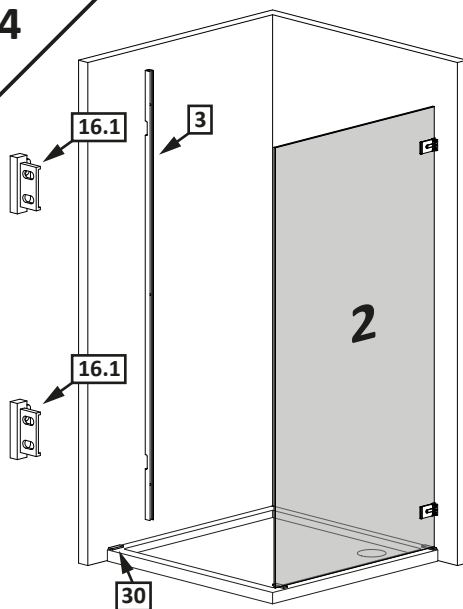

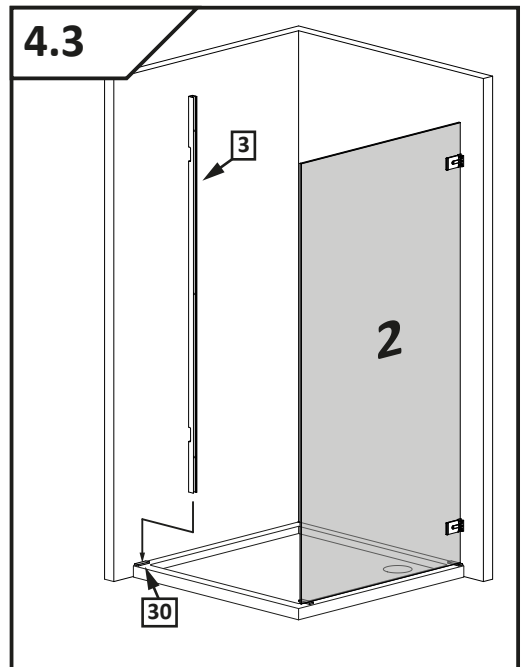
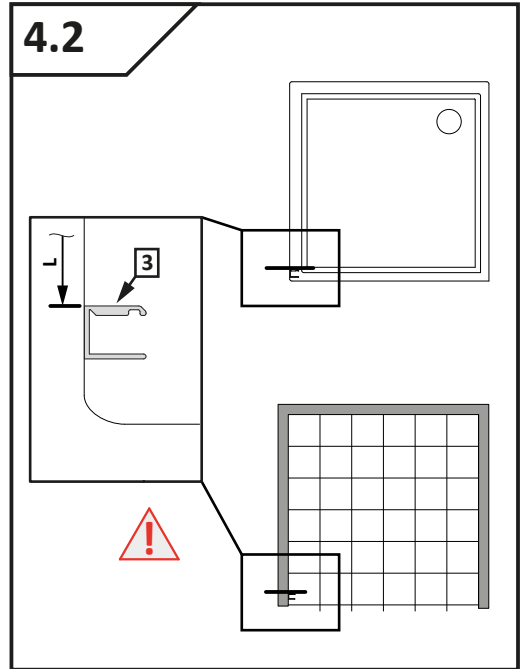
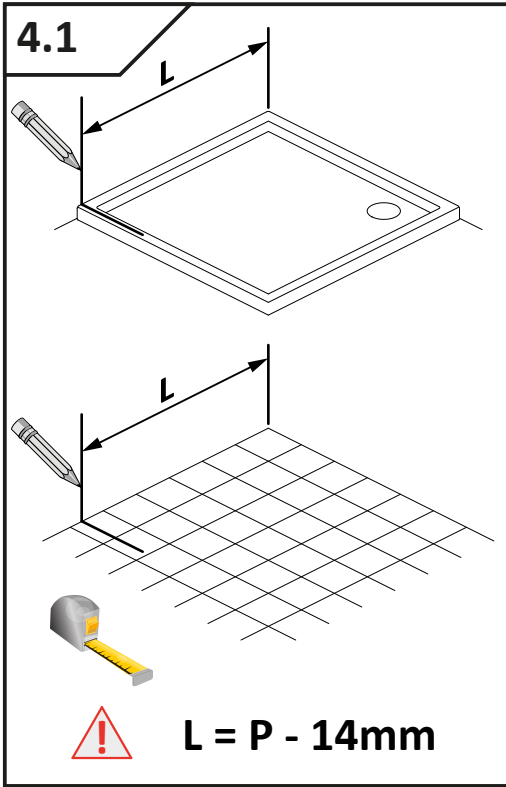

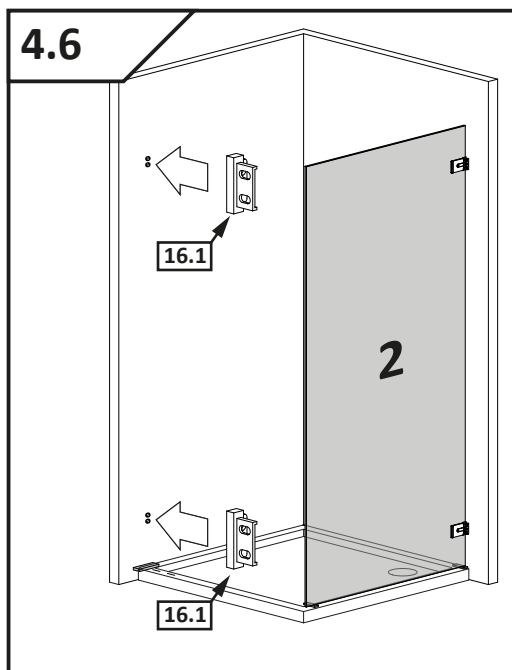
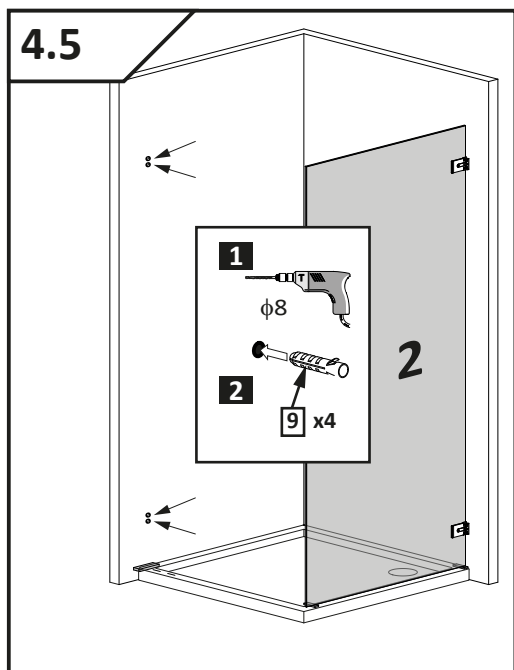
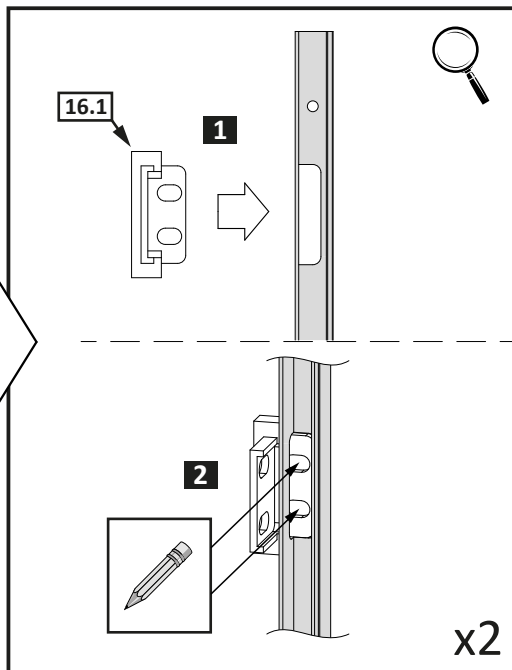
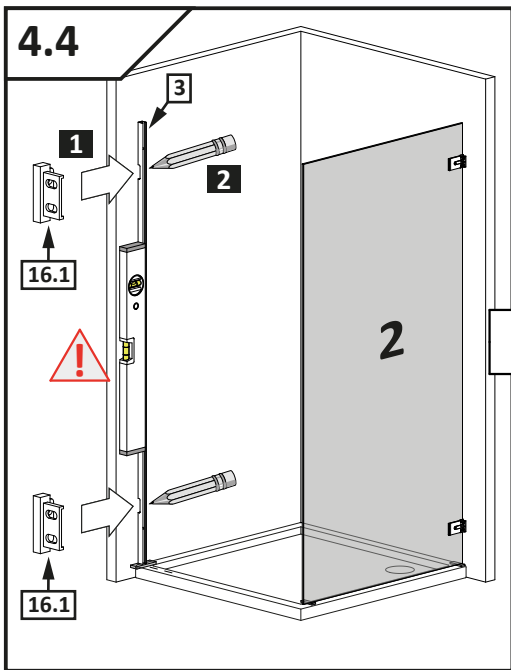

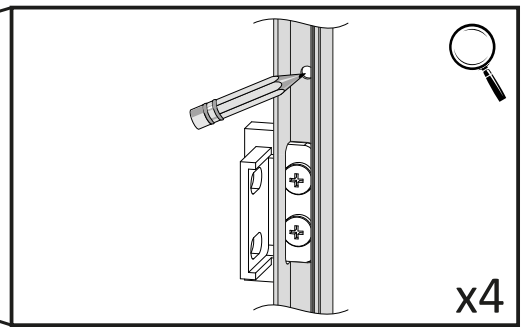
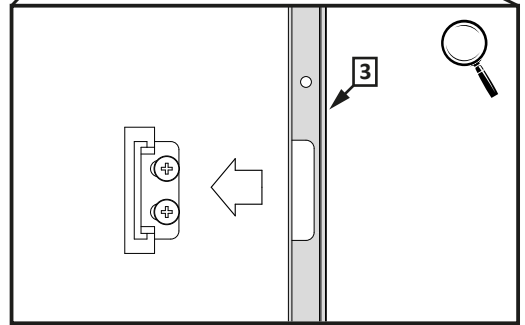
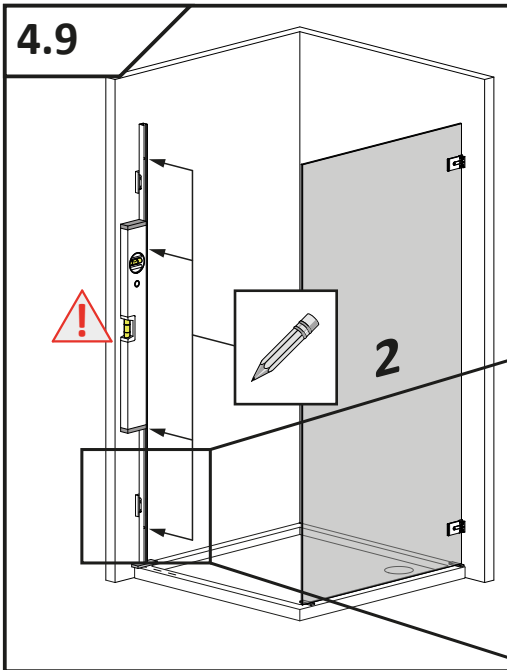
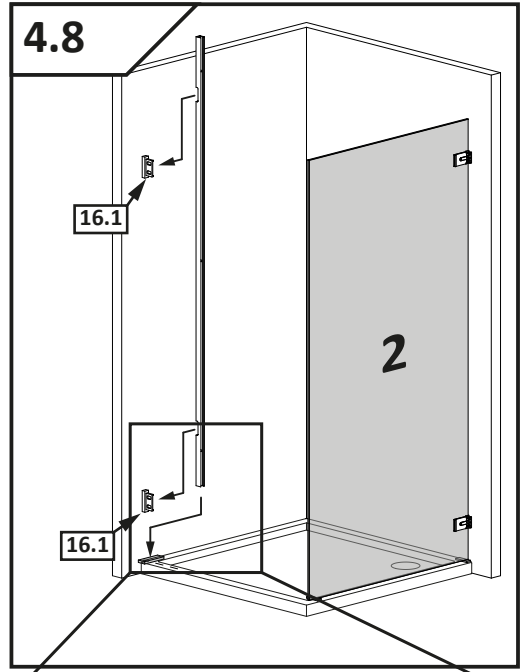
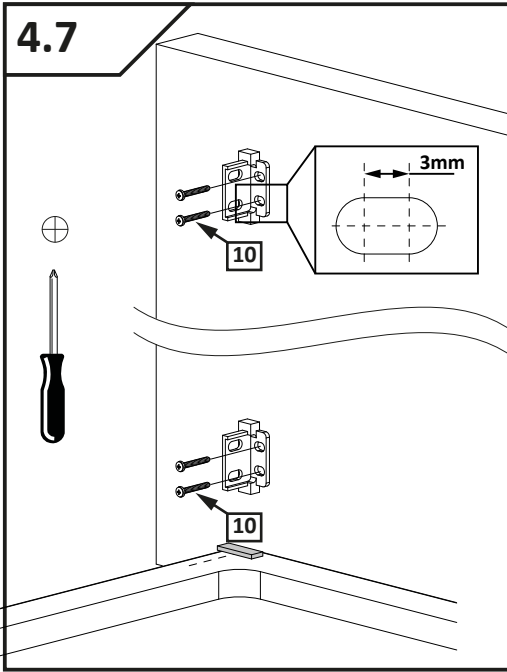

4.10

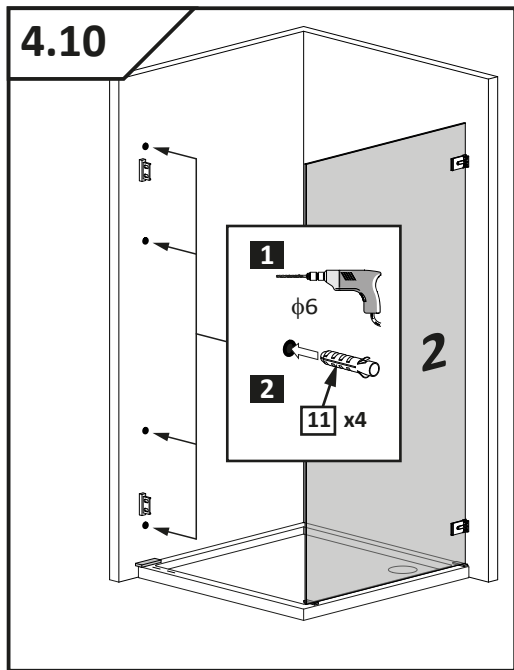

4.11

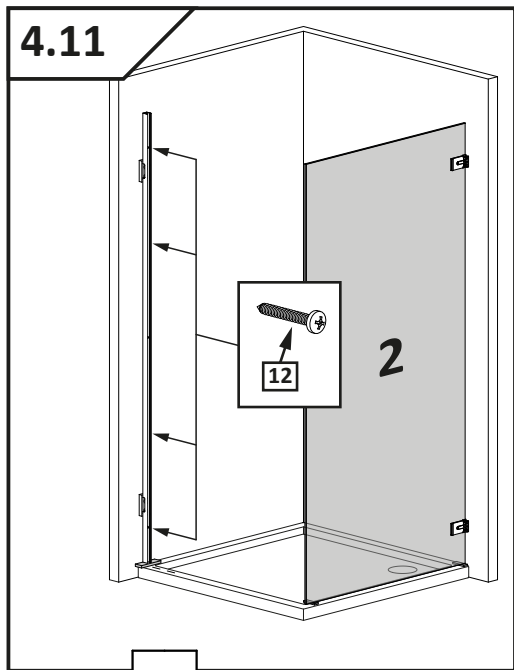

4.12

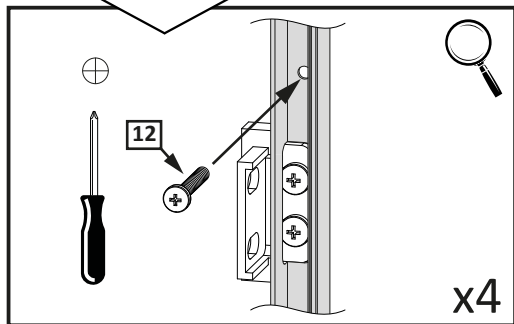
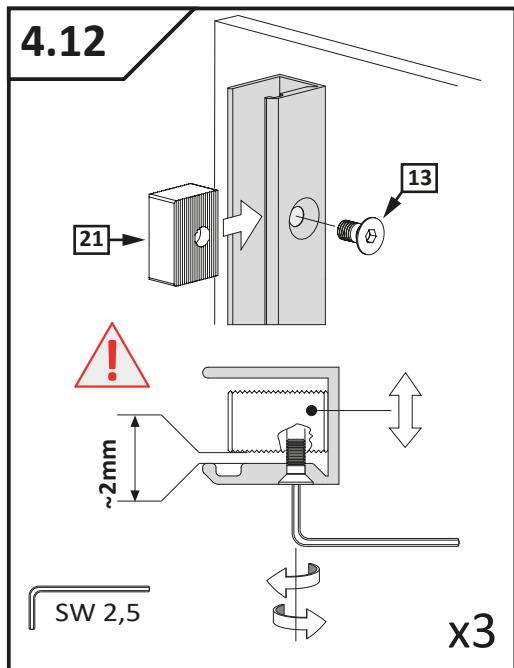

Montaż z listwą progową
Installation with threshold profile
Die Montage mit Schwalleiste
Montovanie s prahovým profilom
Instalace přechodové lišty
Монтаж с профилем порога
Szerelés küszöb profilal
Instalarea cu profil prag
Montage avec barre de seuil
Installazione con profilo di soglia
Instalación con la barra de umbral
 تجميع مع شريط عتبة

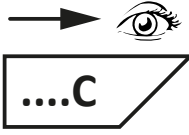

Montaż bez listwy progowej
Installation without threshold profile
Die Montage ohne Schwalleiste
Montovanie bez prahového profilu
Instalace bez prahové lišty
Монтаж без профиля порога
Szerelés küszöb profil nélkül
Instalarea fara profil prag
Montage sans barre de seuil
Installazione senza profilo di soglia
Instalación sin la barra de umbral
 تجميع دون شريط عتبة

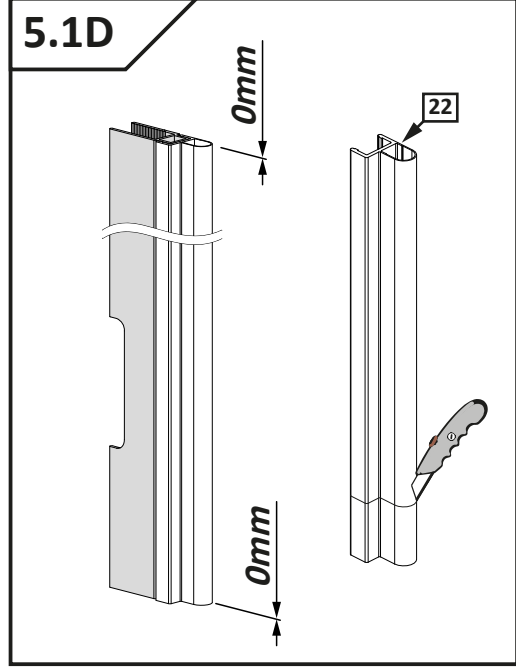
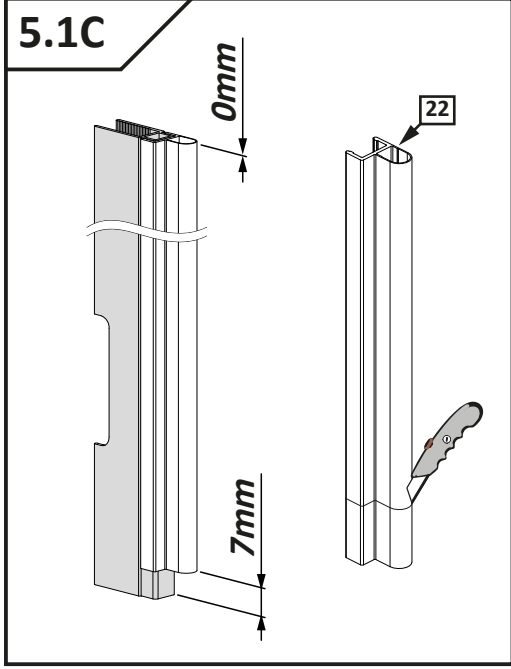
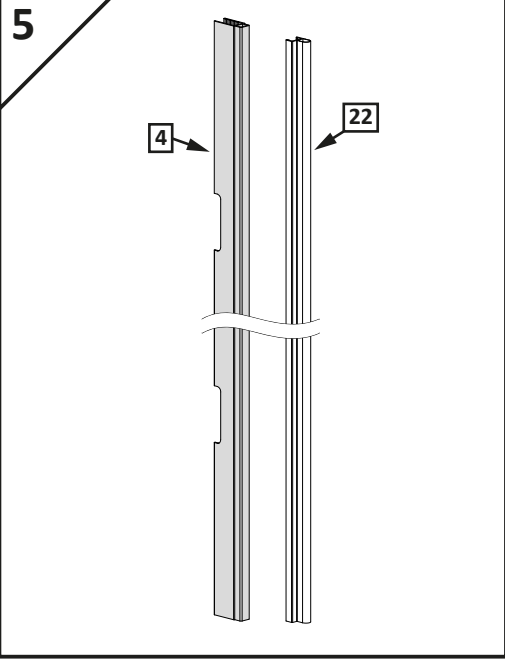
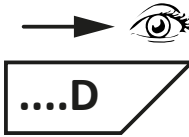

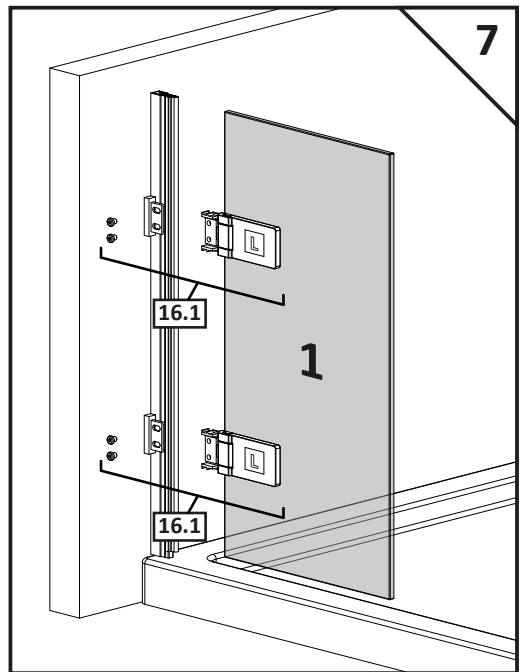
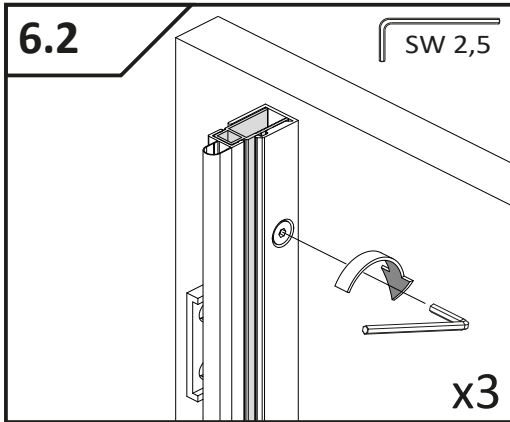
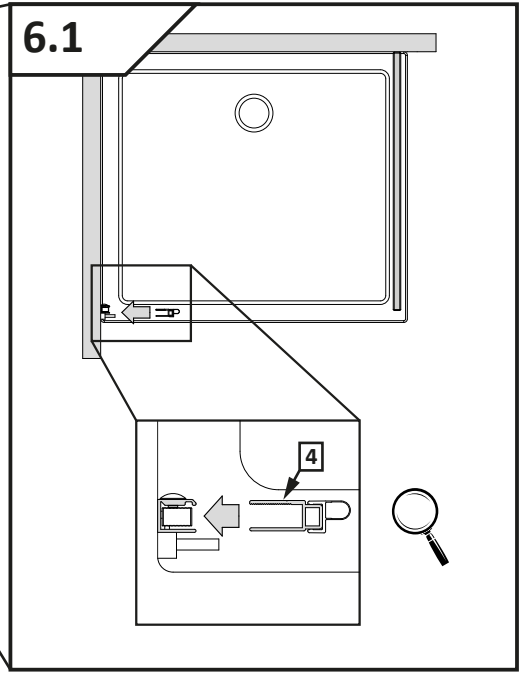
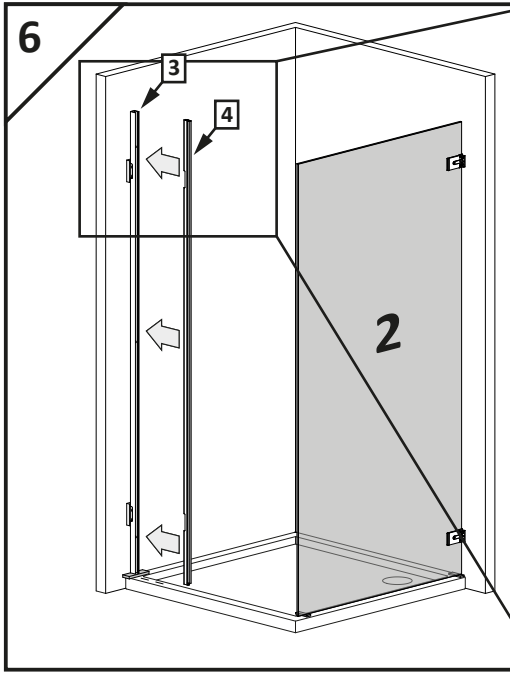

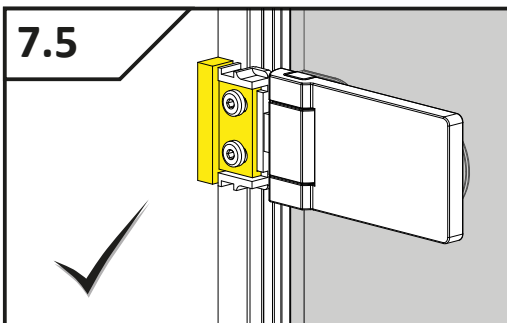
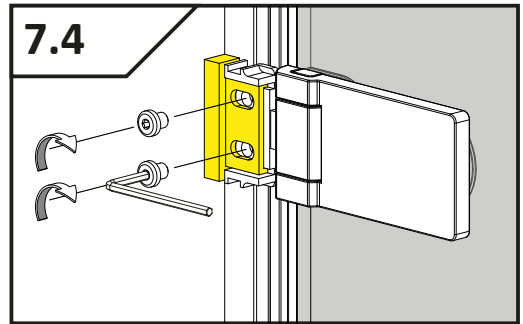
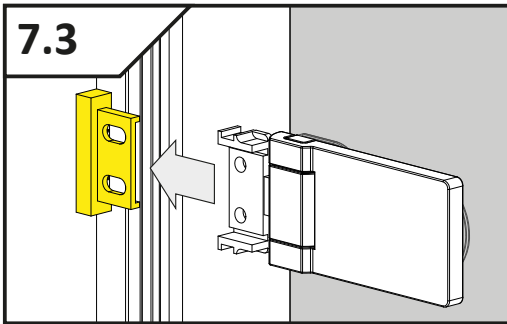
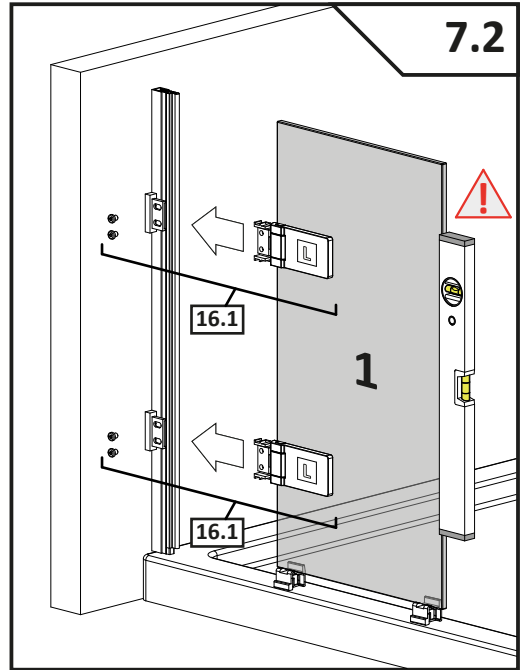
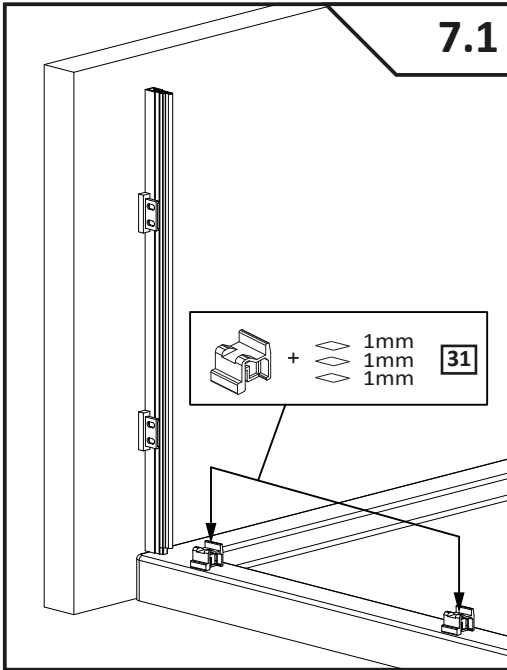

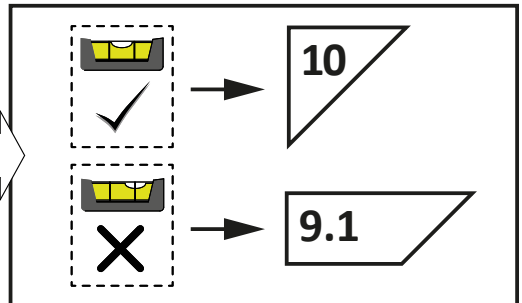
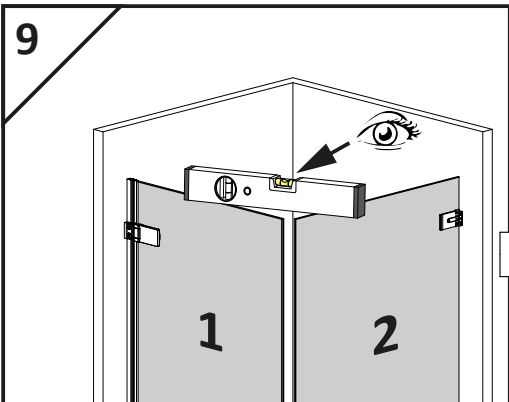
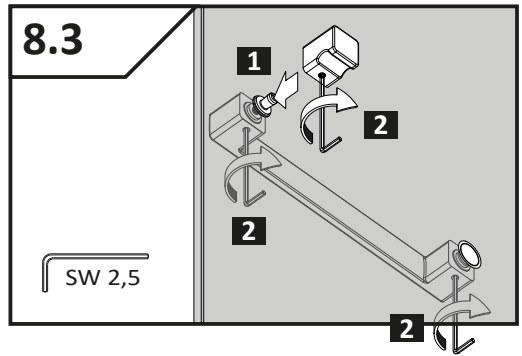
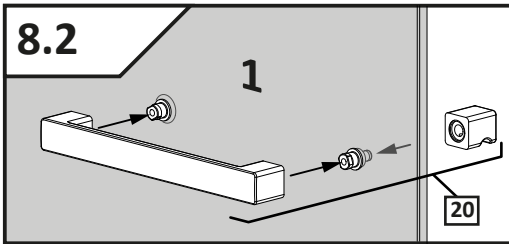
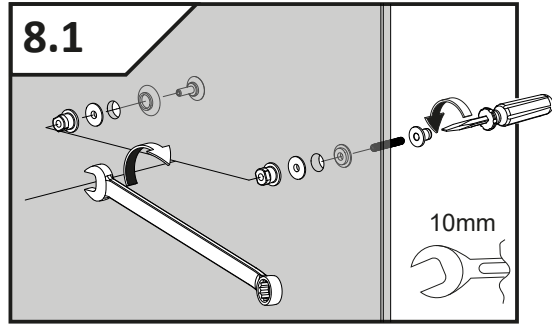
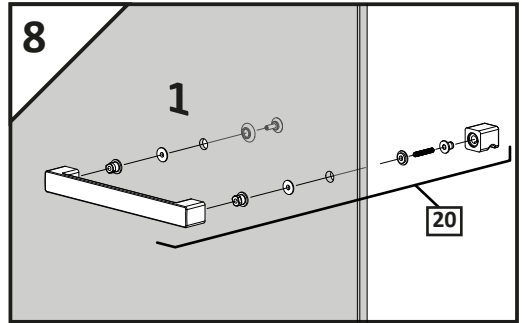
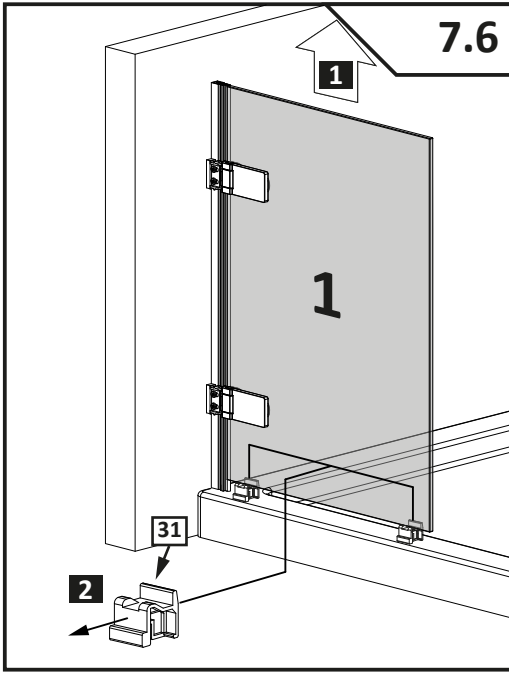

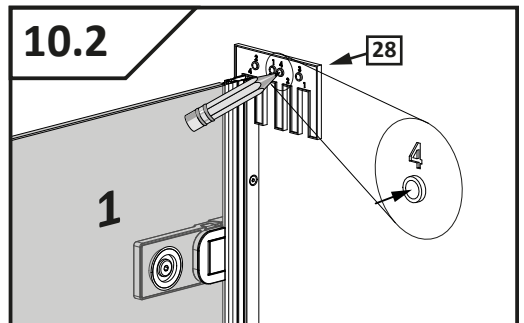
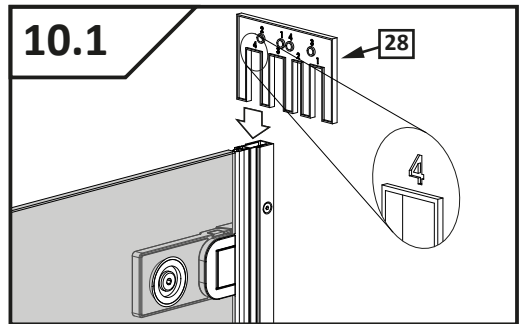
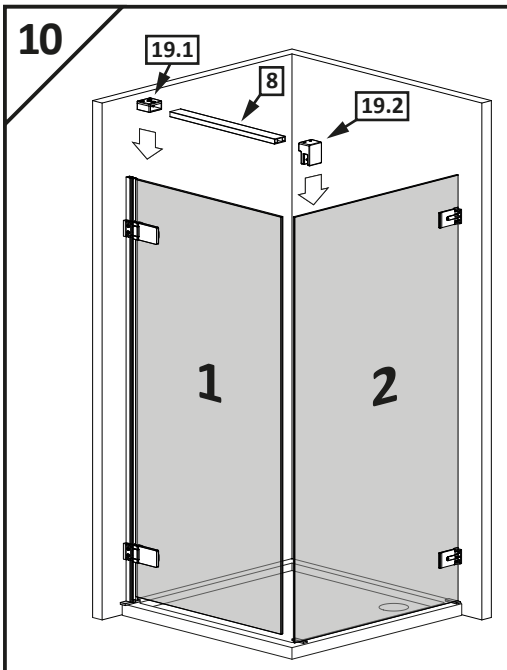
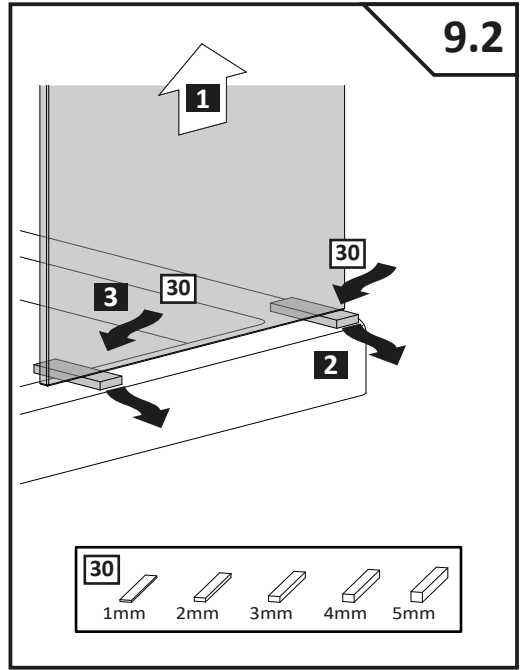
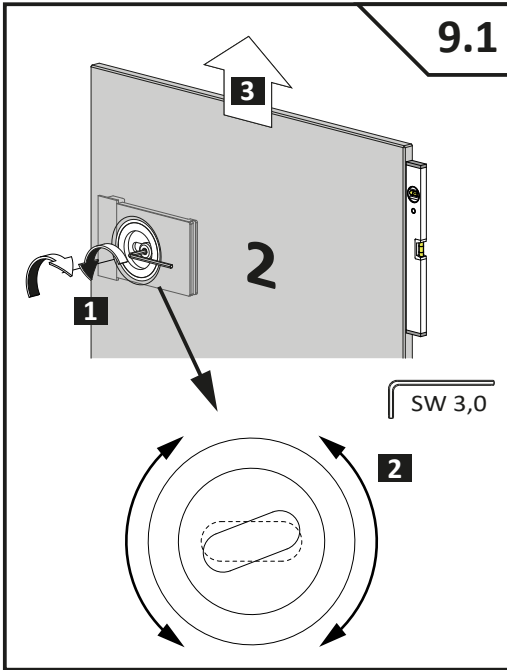

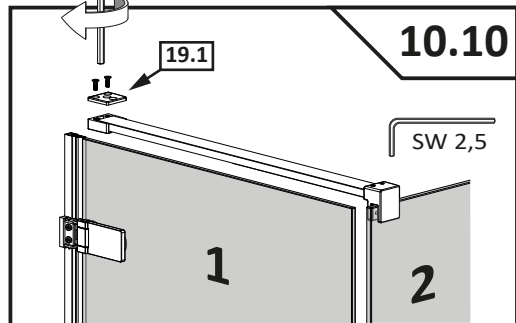
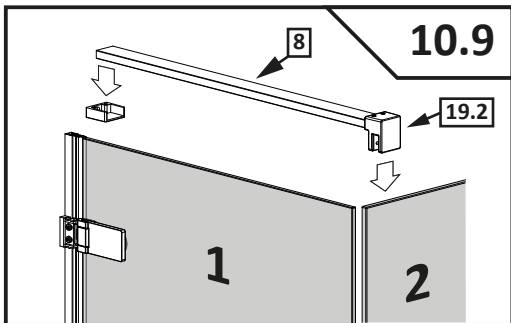
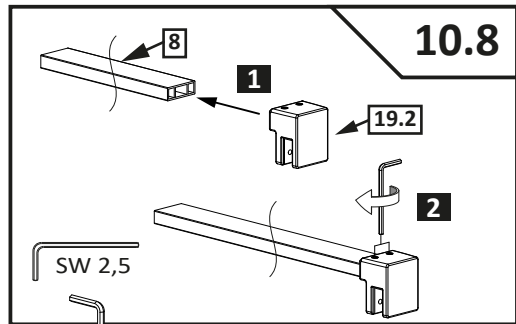
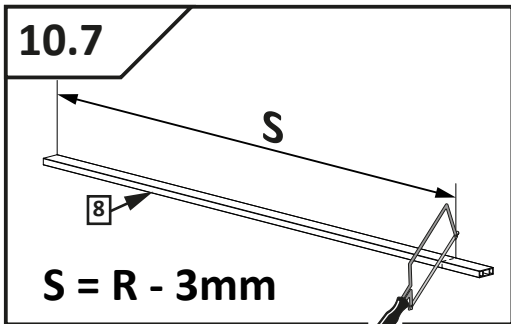
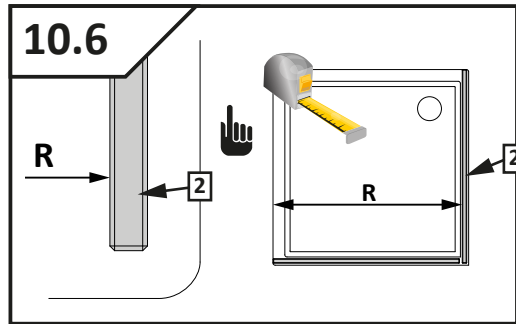
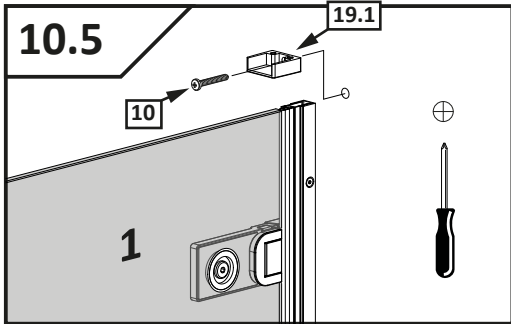
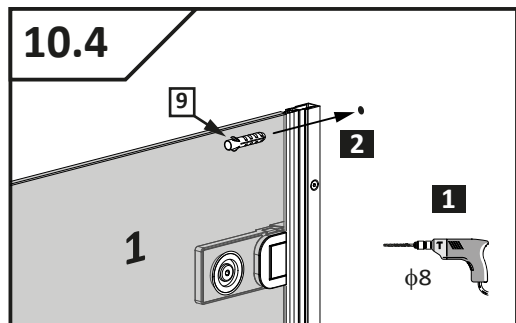
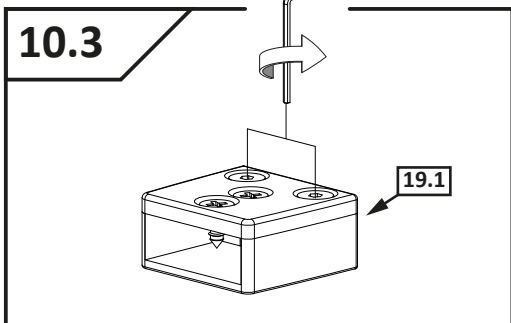

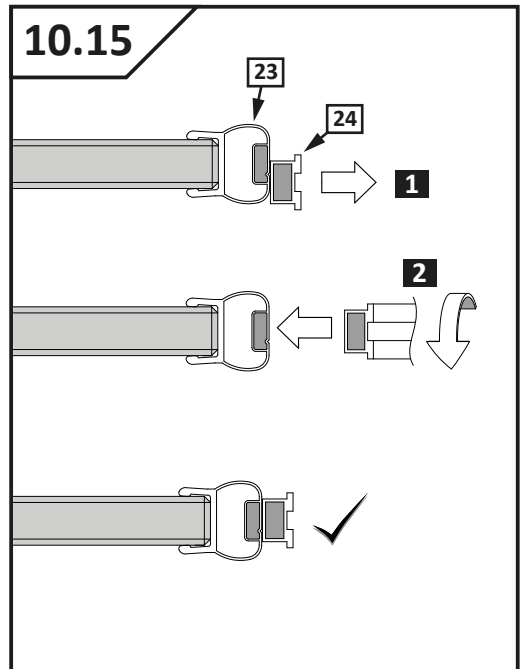
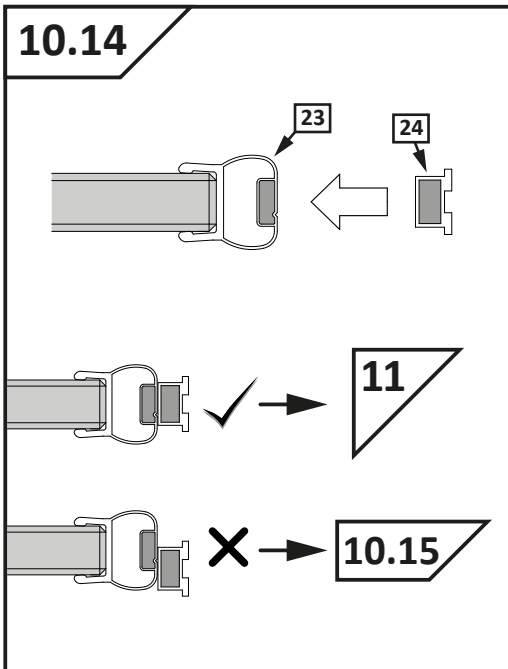
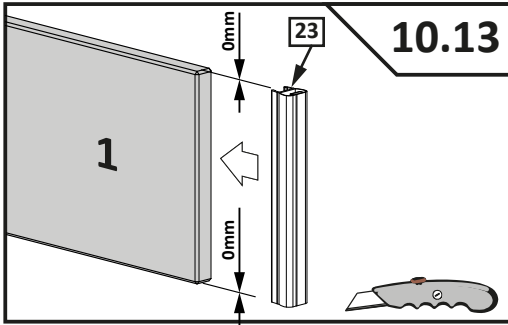
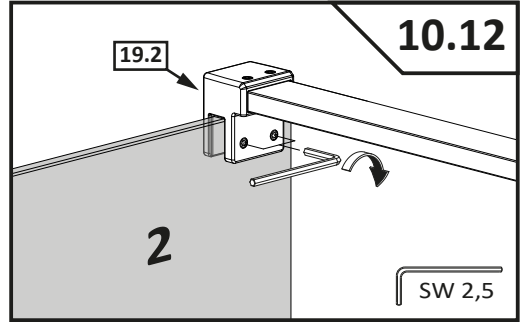
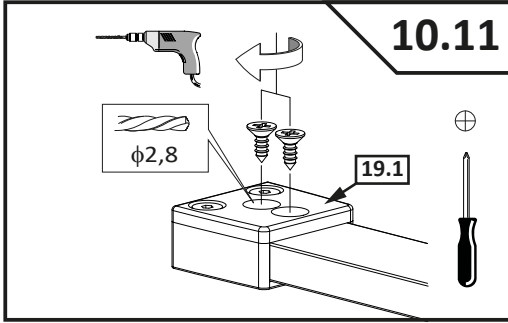

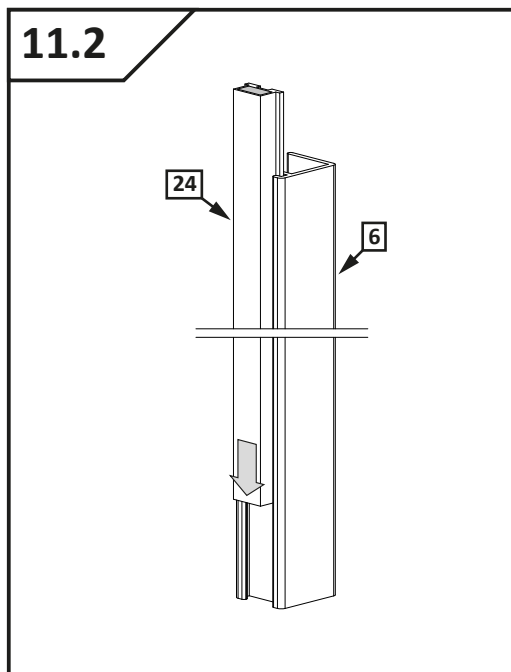
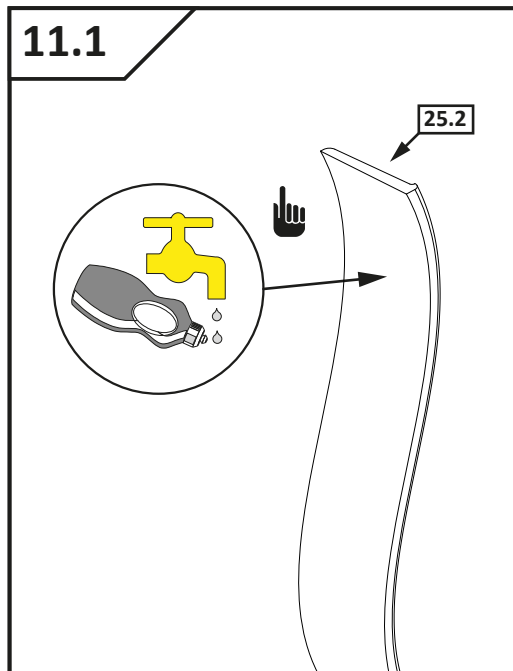
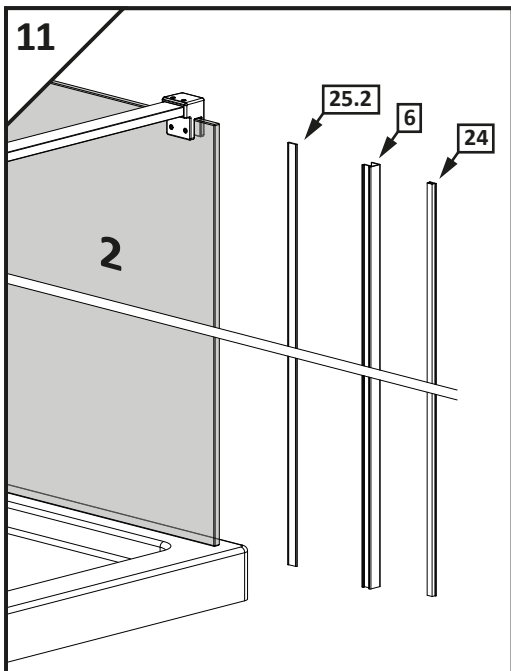

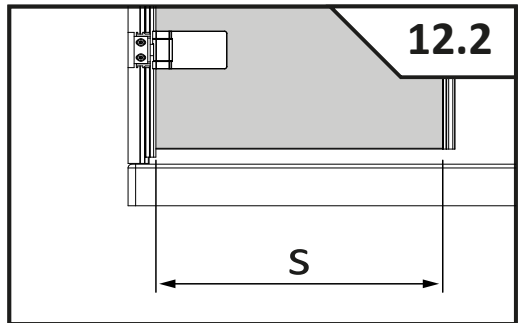
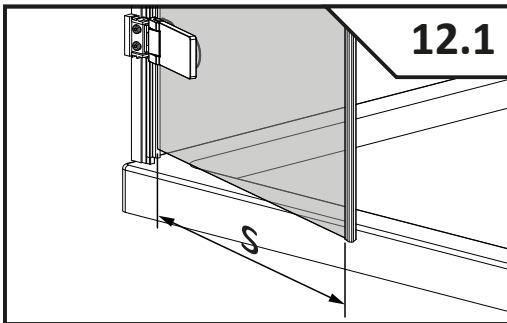
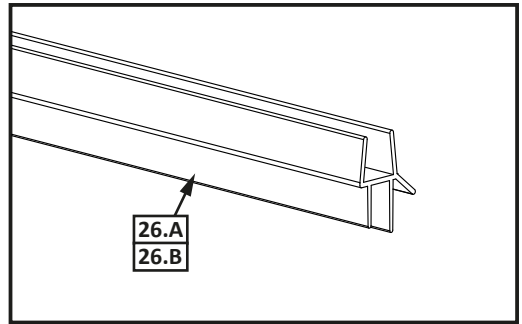
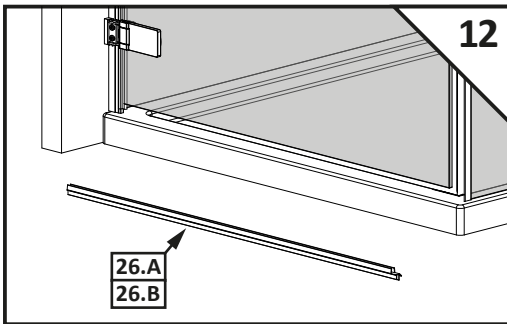
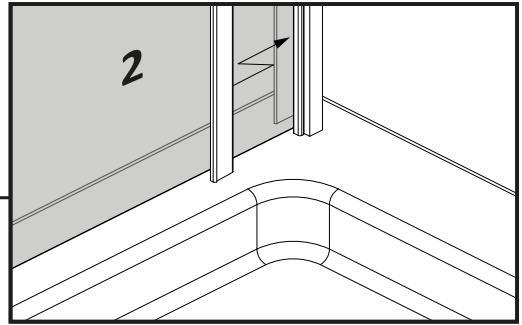
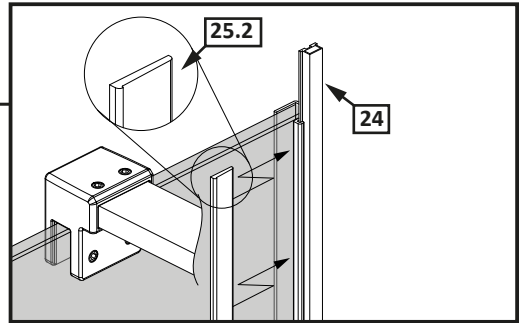
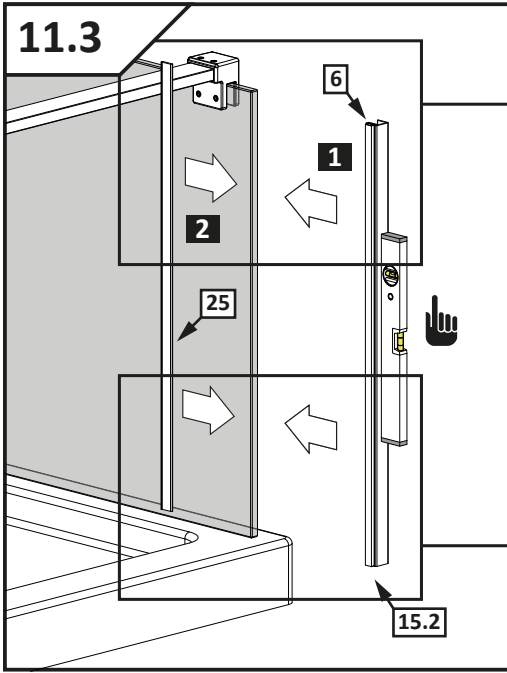

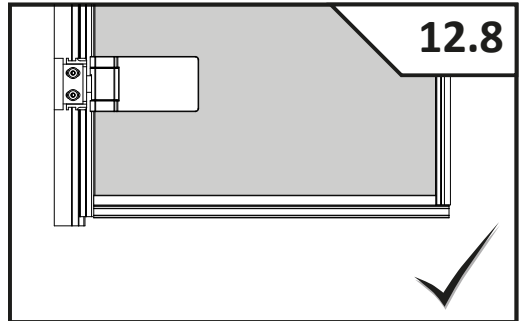
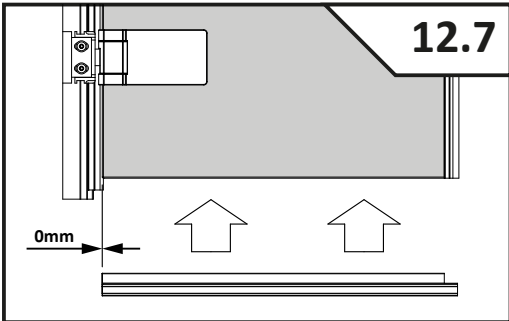
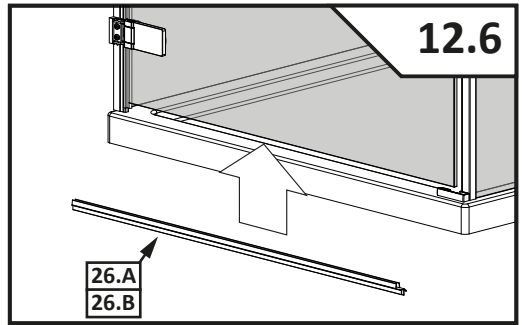
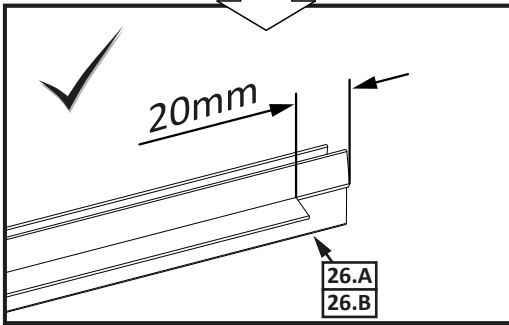
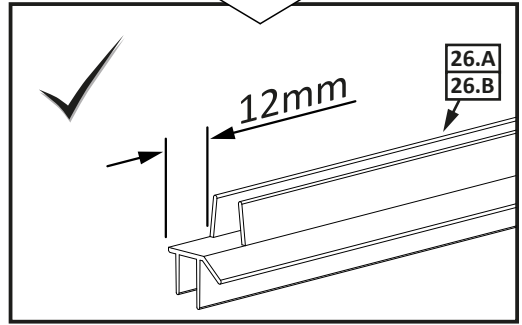
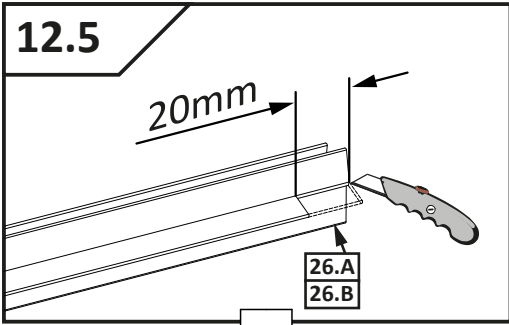
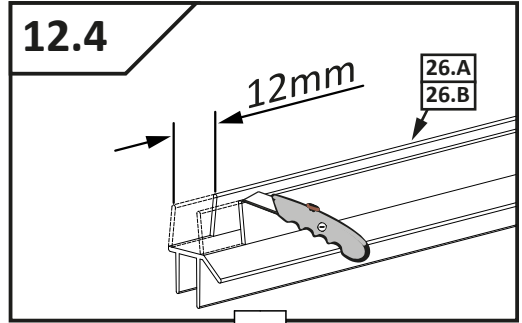
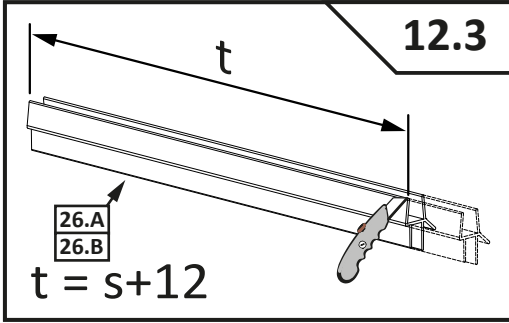

Montaż z listwą progową
Installation with threshold profile
Die Montage mit Schwalleiste
Montovanie s prahovým profilom
Instalace přechodové lišty
Монтаж с профилем порога
Szerelés küszöb profilal
Instalarea cu profil prag
Montage avec barre de seuil
Installazione con profilo di soglia
Instalación con la barra de umbral
 تجميع مع شريط عتبة
....C

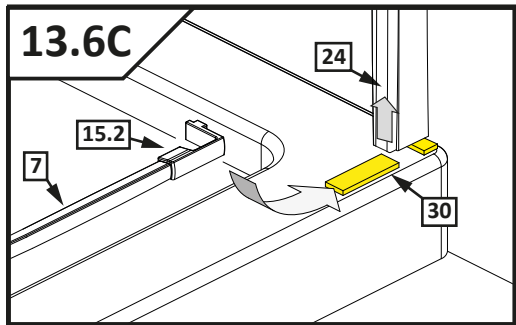
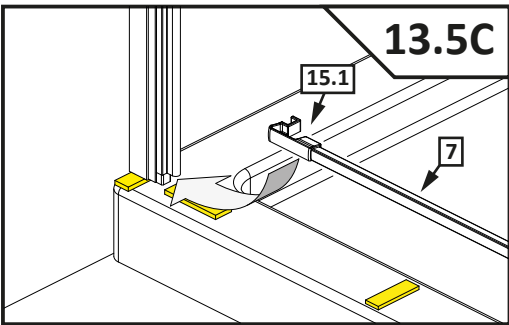
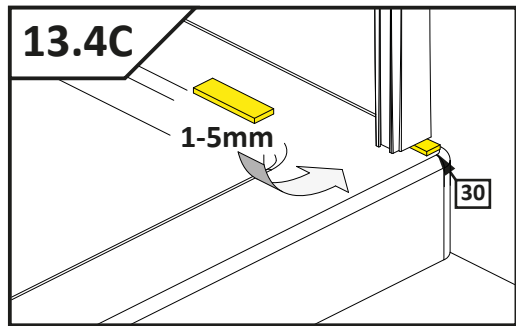
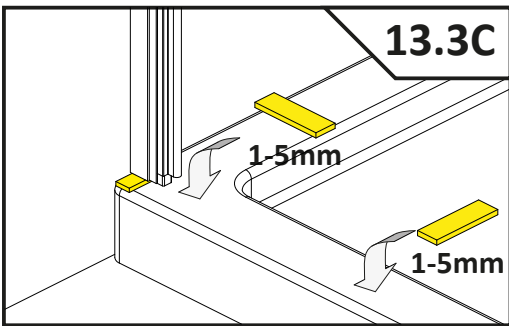
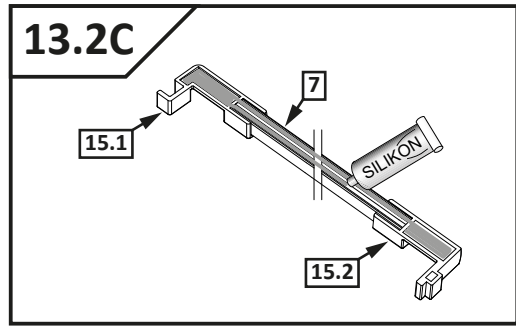
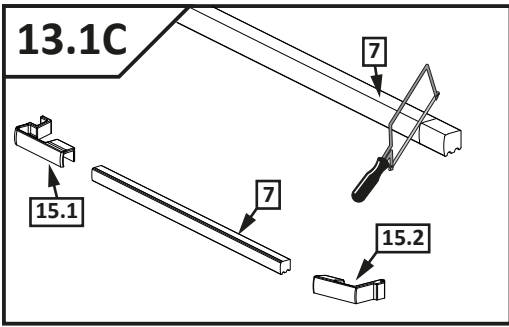
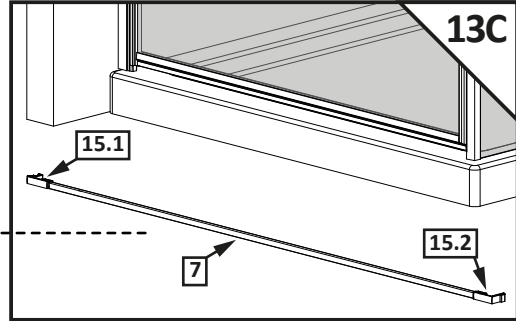

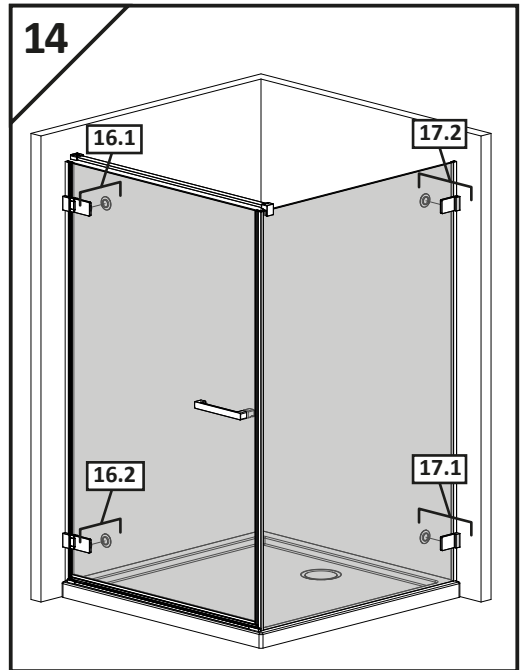
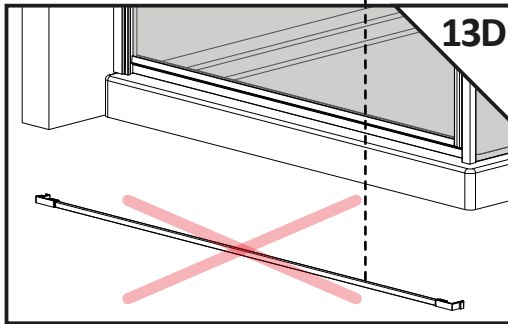
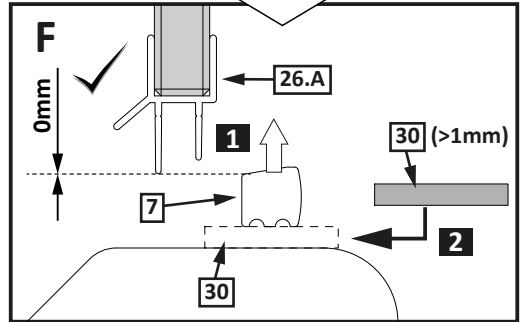
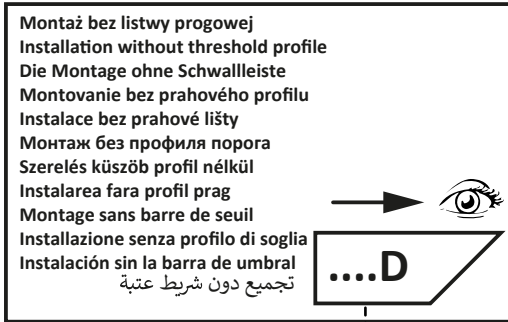
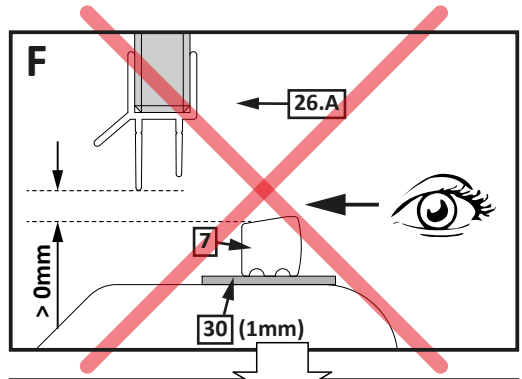
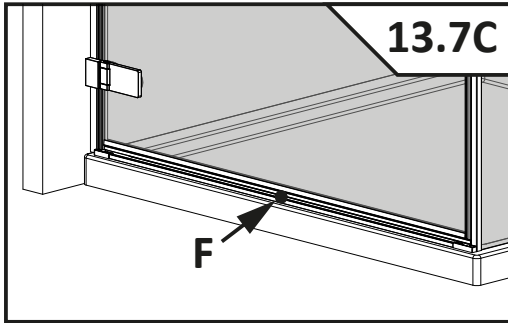

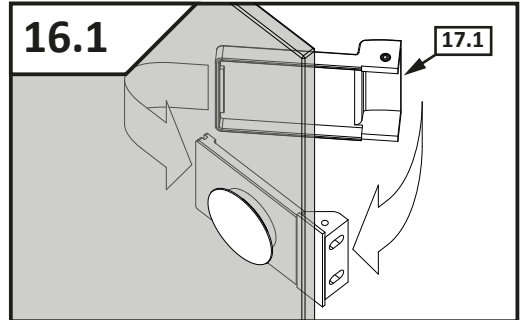
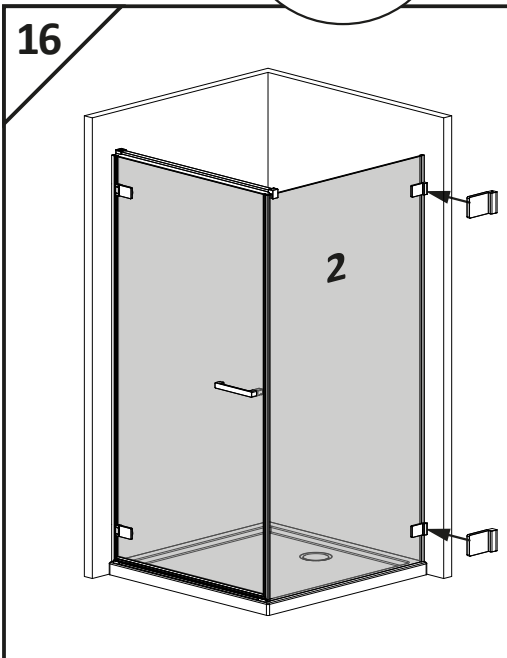
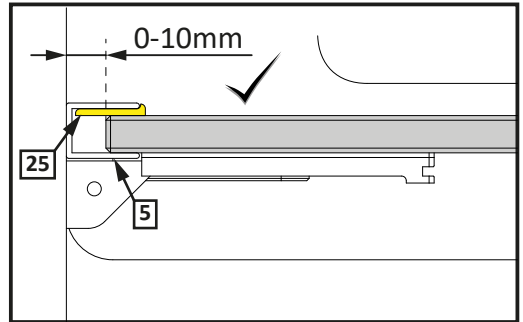
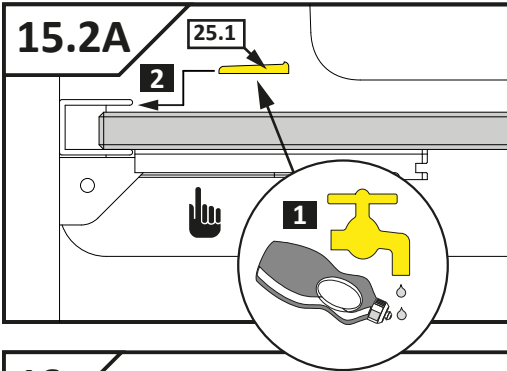
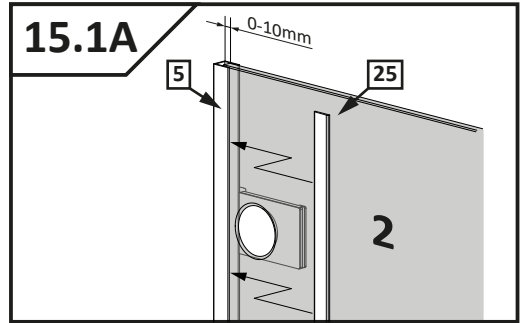
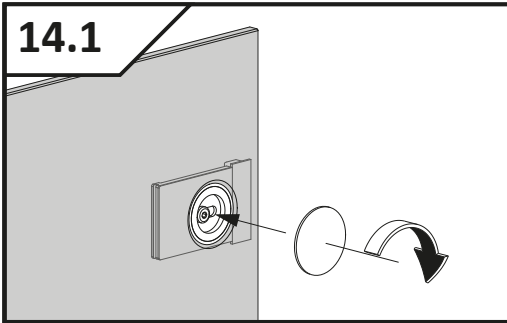

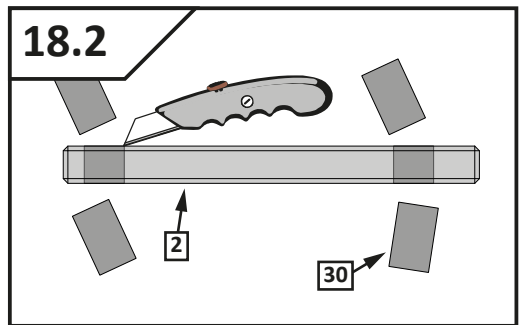
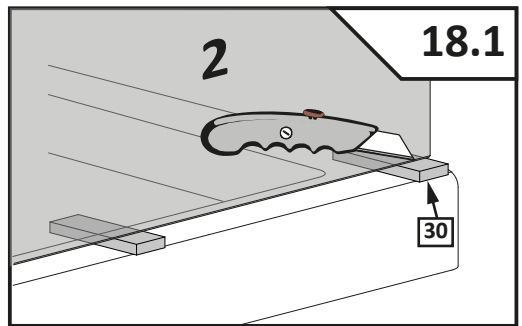
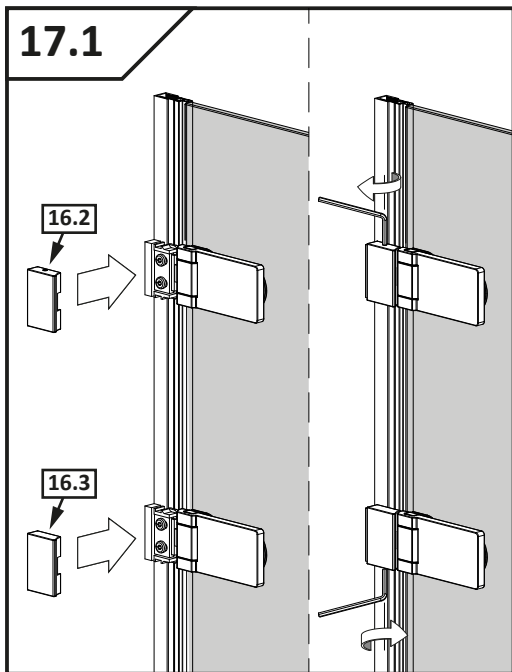
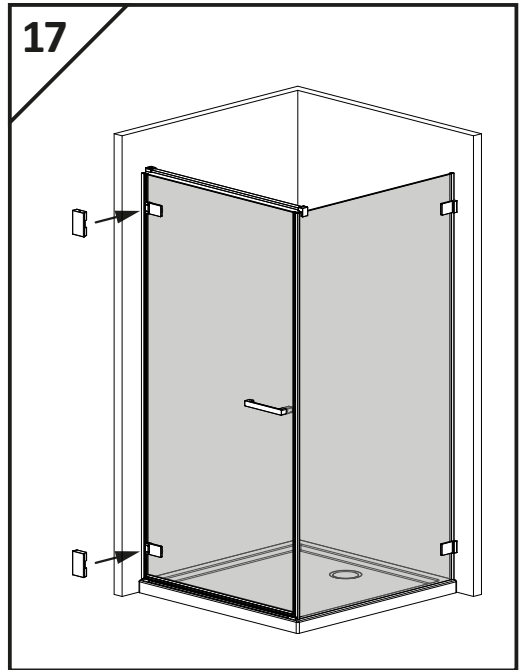
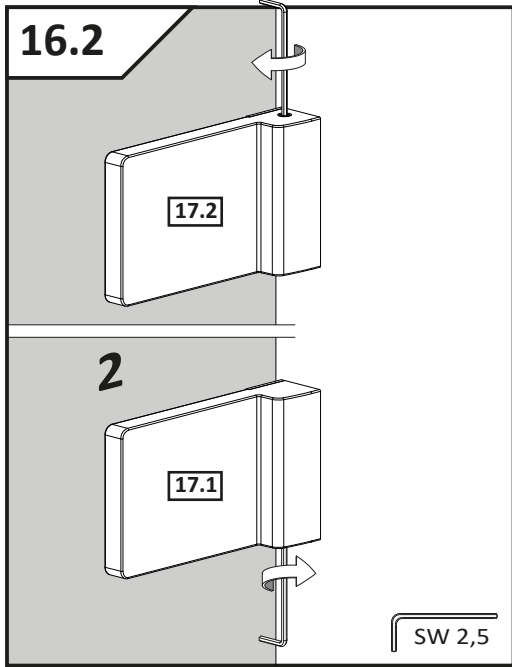

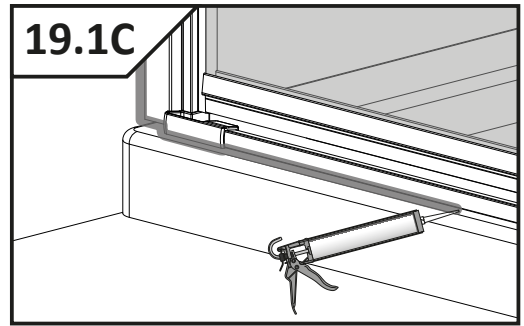
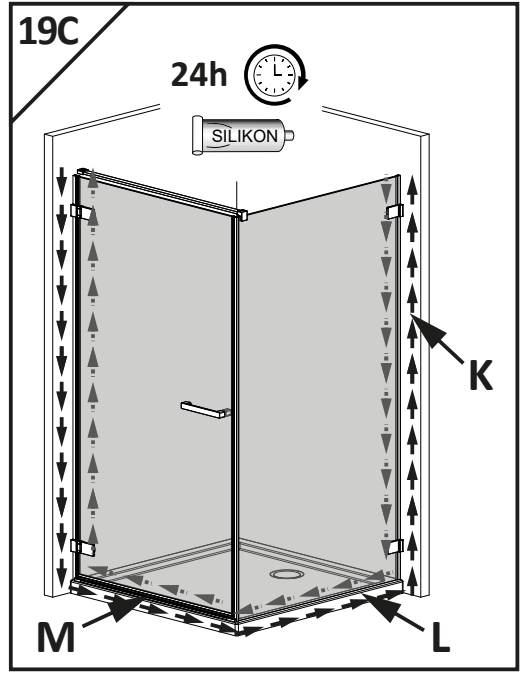
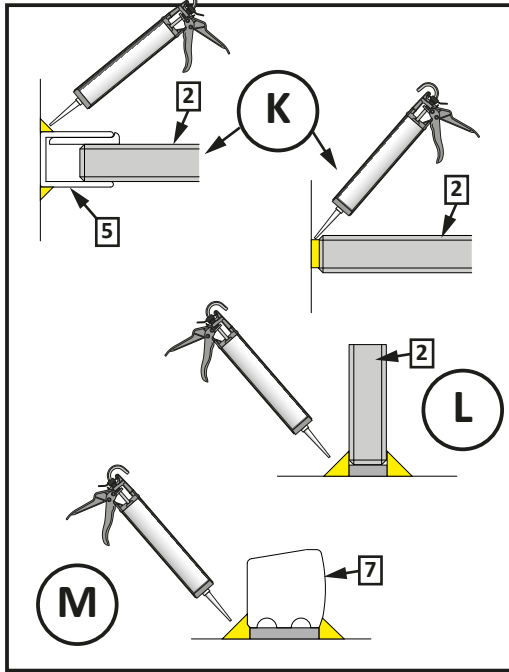
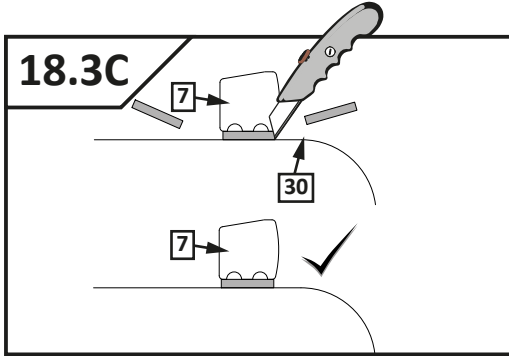

19D

24h 

SILIKON 

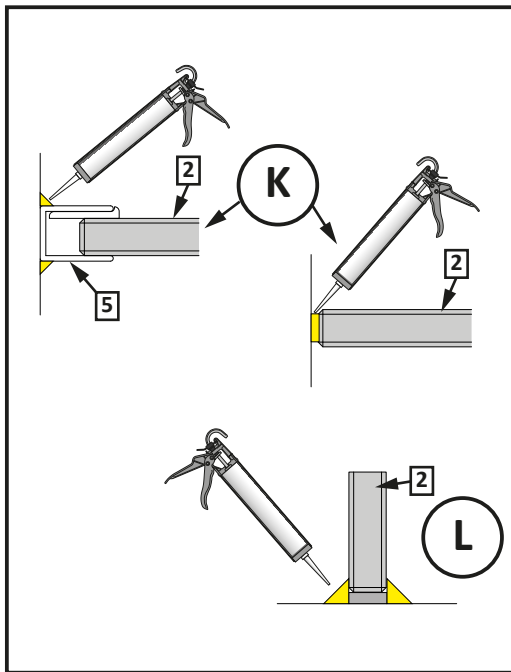
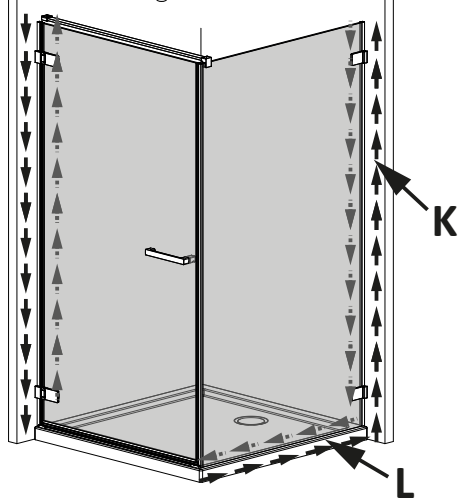

19.1D

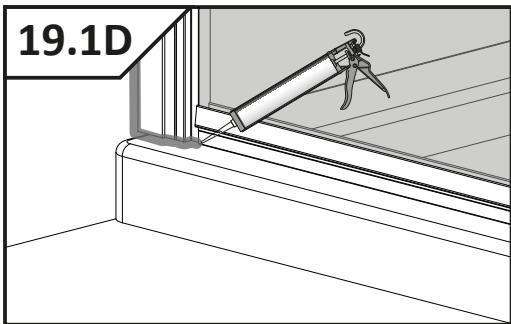

Karbantartási útmutató:



Mind az üvegfelületek, mind a műanyag elemek és az alumínium profilok tisztítására is a gyártó által javasolt tisztítószereket és vízlehúzót célszerű használni. Ezek a **RADAWAY GLASS CLEANER** zuhanykabin tisztítószer és a **RADAWAY GLASS PROTECTOR** védőbevonat-felfrissítő készítmény.

A termék rutinszerű tisztítása

Ajánlott, hogy a kabin közvetlenül minden zuhanyzás után ki legyen tisztítva a következők szerint:

A kabin belső felületeit tiszta vízzel öblítse le, majd a vízcseppeket kézi gumilapáttal húzza le. A króm felületeket, lakkozott profilokat puha törlerönggyel törölje szárazra. Mind az üvegfelületek, mind a műanyag elemek és az alumínium profilok tisztítására is a gyártó által javasolt tisztítószereket célszerű használni.

Kerülje csiszolópaszta, hígítószer, aceton, foszforsav és klórtartalmú fertőtlenítőszer alkalmazását. A használatlaltal és karbantartással kapcsolatos egyéb kérdésével forduljon a forgalmazóhoz bizalommal.

A termék alapos tisztítása, karbantartása

A tisztítás ajánlott gyakorisága: a használat mértékétől és a víz minőségétől függően hetente vagy havonta egy alkalommal. A kabin belső felületeit RADAWAY GLASS CLEANER tisztítószerrel permetezze be. Ahol vastagabb a vízkőréteg, ott puha pamut ronggyal törölje át a felületet, akár úgy is, hogy a kendőre is permetez a tisztítószerből.



Rozsdamentes acélból készült **RADAWAY VÍZLEHÚZÓ**, mely rendszeres használat esetén vízkömentes ragyogást biztosít zuhanykabinjában. Csempe, zuhanykabin, üvegfelület és tükrök vízlehúzásához.

FIGYELEM! A Glass Cleaner tisztítószer ne hagyja 10 percnél tovább hatni! Miután áttörölte vegyszerrel a tisztítandó felületet, vízzel öblítse azt le. A vízcseppeket kézi vízlehúzóval távolítsa el. A külső felületeken is elvégezheti a tisztítást, azonban ebben az esetben ügyeljen a padlóra távozó vízmennyiségre. A króm felületeket, lakkozott profilokat puha törlerönggyel törölje szárazra. Ajánlott a RADAWAY GLASS PROTECTOR vegszerrel az üvegfelületek impregnálása. Gondoskodjon a helység megfelelő szellőzéséről a gyors száradás elősegítéséhez.

FIGYELEM! A zuhanykabinok, krómozott szerelvényeik és felületeik tisztításához csak citromsav bázisú vegyszer használata a megengedett. Ecetsav, sósav, hangyasav alapú tisztítószer használata TILOS, ezek jelentős károkat okozhatnak a krómozott felületeken is. Foszfor tartalmú tisztítószer csak korlátozottan használható továbbá a különböző tisztítószer keverése szintén nem megengedett.