

SCALE 1 : 10
BOTTOM VIEW

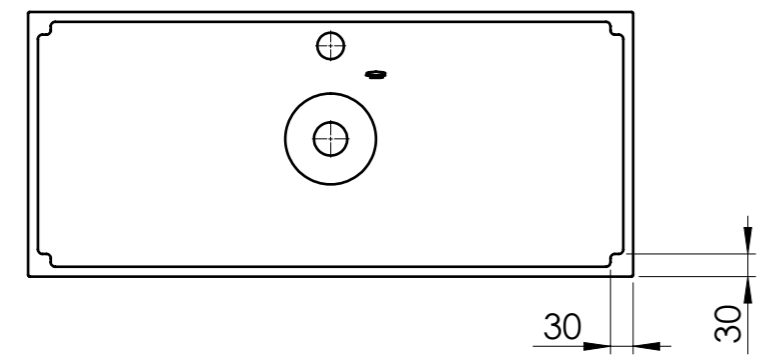

Tolerance length	+3/-0 mm	Drawn by	Created Date	Checked by	Art. Name:
Tolerance length granite	+1.5/-1.5 mm	Project status	Client		Art. No: 6121960811xx
Tolerance Taphole Location	+3/-3 mm				Customer ID: STD
Tolerance overflowhole Location	+3/-3 mm				Material volume[mm³]
Tolerance plane bending	+1.5/-1.5 mm				Overflow
					Taphole
					1
					Main dimensions L x W / H [mm]
					800 x 350 / 50
					Drain
					Surface area[mm²]
					Sheet Size
					Scale
					1:5
					Current revision
					1.0