

# Wellis®

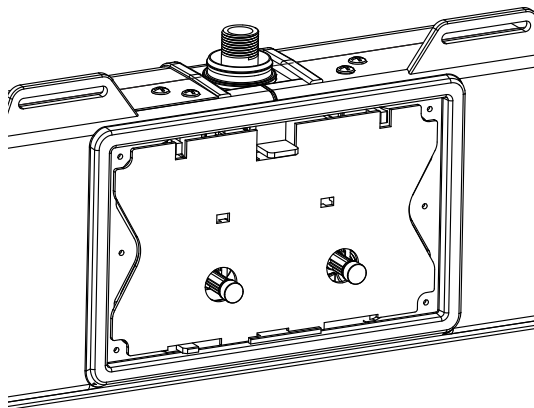

EN

**Push button for Clarice wall behind the toilet**  
INSTALLATION MANUAL

HU

**Nyomógomb Clarice fal mögötti WC tartályhoz**  
SZERELÉSI ÚTMUTATÓ

DE

**Drucktaste für Clarice-Wand hinter der Toilette**  
INSTALLATIONSANLEITUNG

FR

**Bouton poussoir pour le mur Clarice derrière les toilettes**  
MANUEL D'INSTALLATION

RO

**Buton pentru rezervor încastat Clarice**  
INSTRUCȚIUNI DE MONTARE

EE00274  
EE00275

**CLARICE**

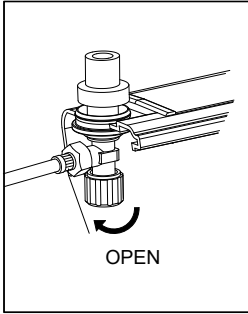

1、 Open the stop valve to let water in

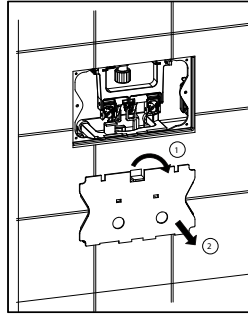

2、 Take the cistern's plate out from the cistern

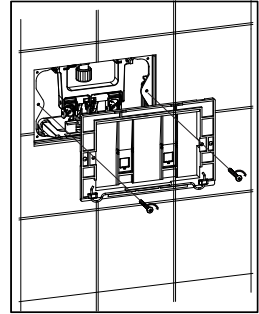

3、 Fix the control plate base fasten the screw, torque force less than 25 N.m

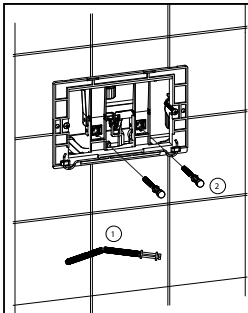

4、 Screw in the adjustment levers of the control plate button

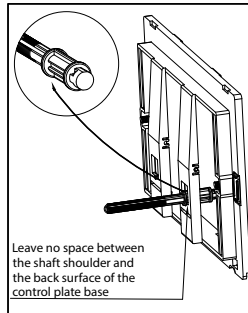

5、 Adjust the levers to a right position

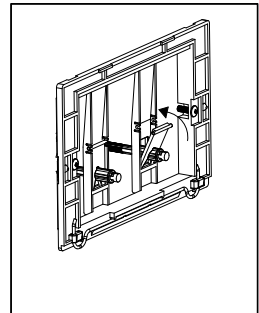

6、 Install the block as suggested

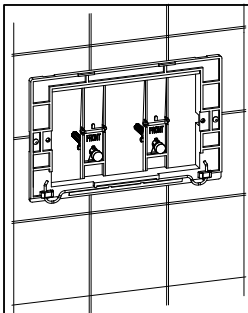

7、 Make sure every fixing part is in place and adjustment levers of the control plate button work well

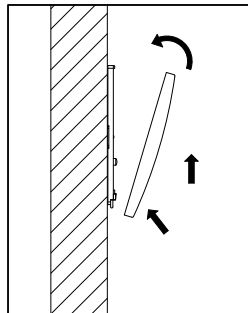

8、 Fix the control plate as shown in the picture

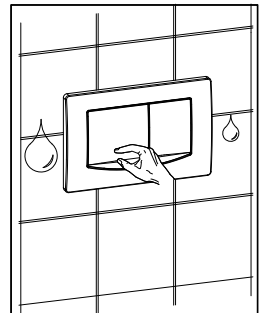

9、 Check the water flush by pressing the half-flush and full-flush buttons

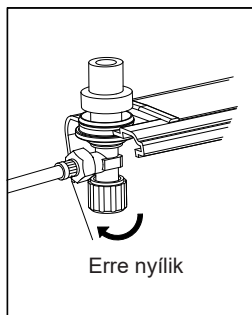

1. Nyissa meg a zárószелеpet a víz beengedéséhez

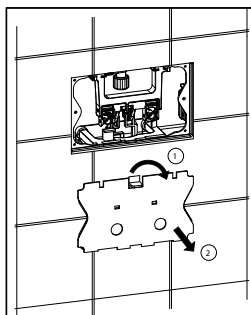

2. Vegye le a tartálylemez víztárolóról

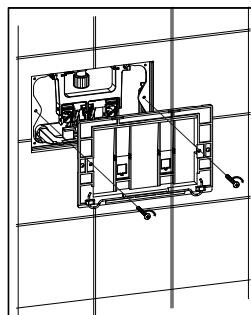

3. Rögzítse a vezérlőpanel lapját szorítsa meg a csavart.

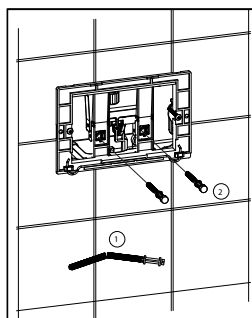

4. Csavarja be a vezérlőpanel beállítójait

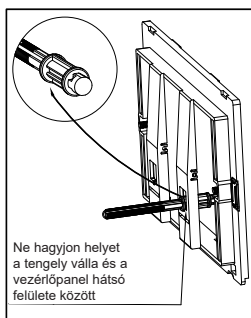

5. Állítsa be a karokat a megfelelő pozícióba

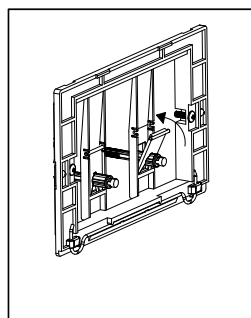

6. Az útmutatás szerint szerelje fel a blokkot

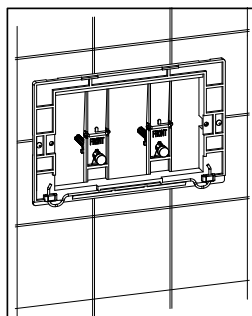

7. Győződjön meg róla, hogy minden rögzítőelem a helyén van, és hogy a vezérlőpanel gombjainak beállítójai jól működnek

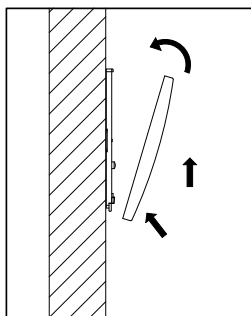

8. A képen láthatóak szerint rögzítse a vezérlőpanelt

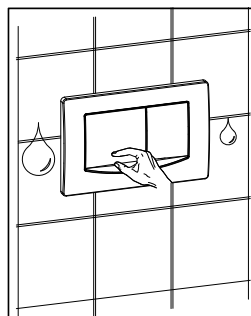

9. Ellenőrizze a vízöblítést a fél öblítés és a teljes öblítés gombjainak megnyomásával

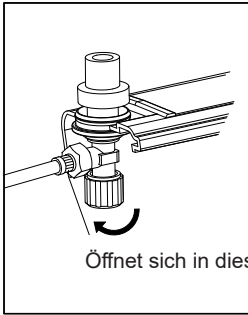

Öffnet sich in diese Richtung

1. Öffnen Sie das Schließventil, damit Wasser eindringen kann

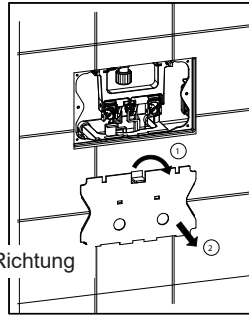

2. Entfernen Sie die Platte aus dem Spülkasten.

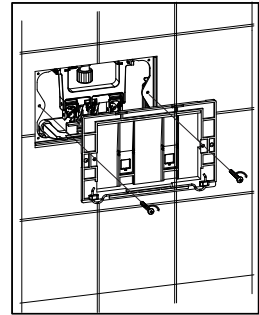

3. Sichern Sie die Schalttafelplatte durch Anziehen der Schraube.

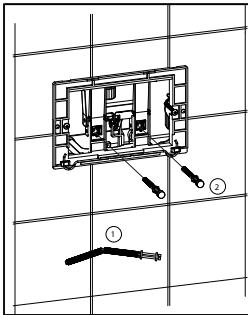

4. Schrauben Sie die Bedienfeldhebel ein

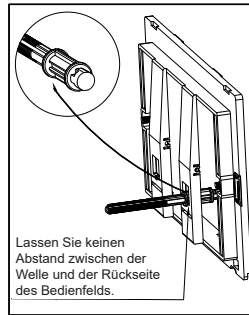

5. Stellen Sie die Hebel auf die richtige Position ein

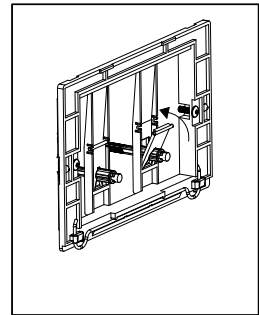

6. Installieren Sie den Block wie angewiesen

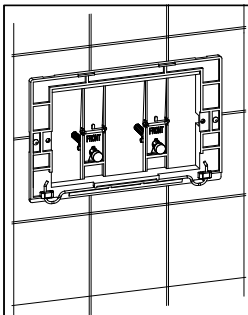

7. Vergewissern Sie sich, dass alle Befestigungen vorhanden sind und die Hebel der Bedienfeldtasten einwandfrei funktionieren.

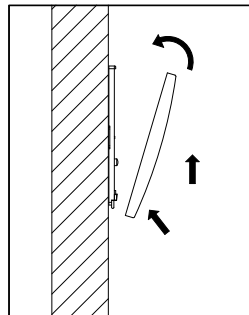

8. Befestigen Sie das Bedienfeld wie auf dem Bild gezeigt.

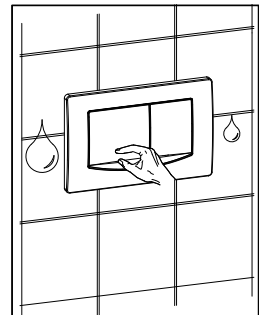

9. Überprüfen Sie die Wasserspülung, indem Sie die Halbspül- und die Vollspül-Taste drücken!

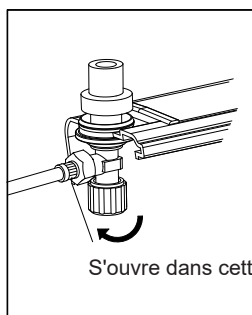

S'ouvre dans cette direction

1. Ouvrez la vanne de fermeture pour laisser entrer l'eau

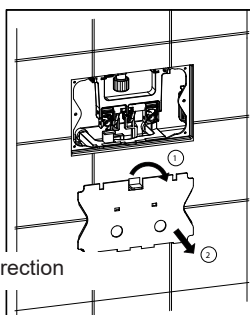

2. Retirez la plaque du réservoir

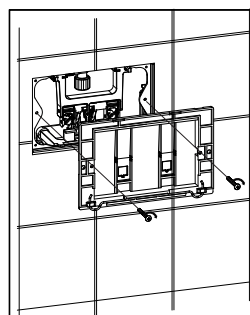

3. Fixez le panneau de commande en resserrant la vis.

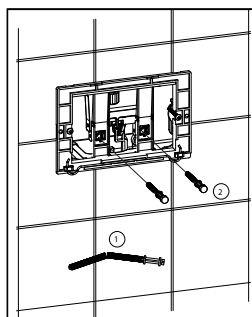

4. Vissez les leviers du panneau de commande

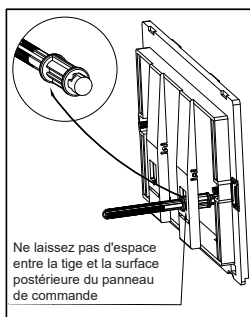

Ne laissez pas d'espace entre la tige et la surface postérieure du panneau de commande

5. Ajustez les leviers dans la position correcte

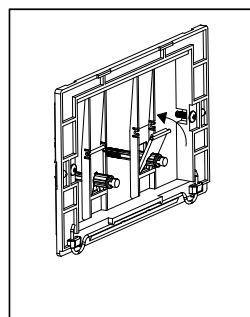

6. Installez le bloc comme indiqué

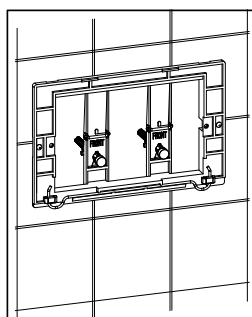

7. Assurez-vous que toutes les fixations soient en place et que les leviers du panneau de commande fonctionnent correctement

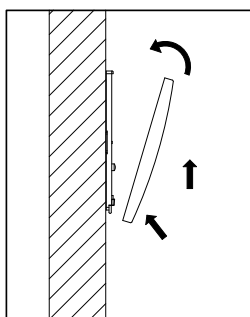

8. Fixez le panneau de commande comme indiqué sur le schéma

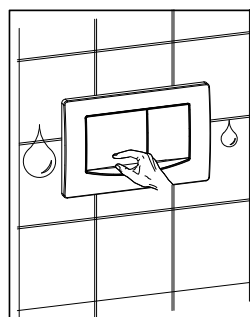

9. Vérifiez le fonctionnement de la chasse d'eau en appuyant sur les boutons de demi-déchargé et de déchargé

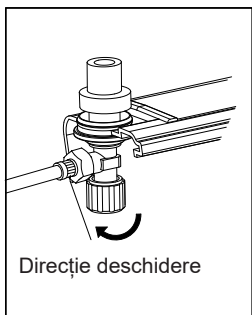

1. Deschideți ventilul pentru a porni apa

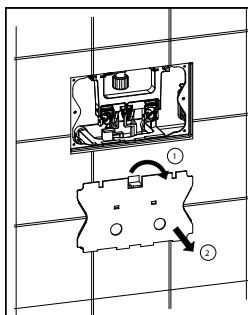

2. Scoateți placa de pe rezervor

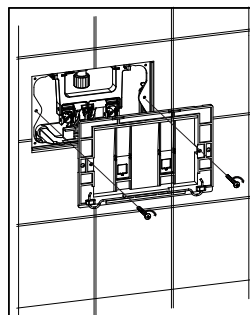

3. Fixați placa panoului de comandă, strângeți șurubul.

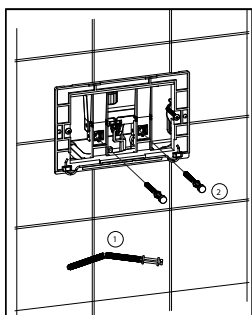

4. Înșurubați brațele de reglare a panoului de comandă

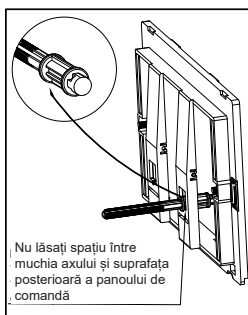

5. Reglați brațele în poziția corespunzătoare

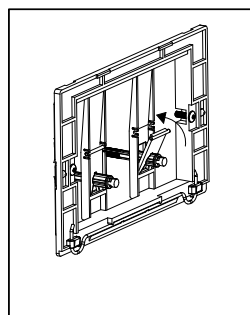

6. Montați blocul conform instrucțiunilor

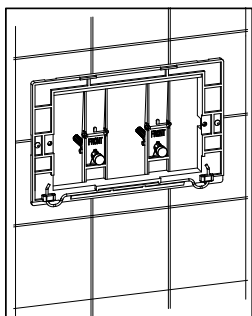

7. Asigurați-vă că toate elementele de fixare se află la locul lor și că brațele de reglare a panoului de comandă funcționează corespunzător

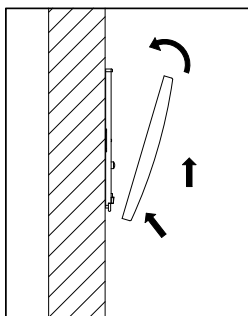

8. Fixați panoul de comandă conform imaginii

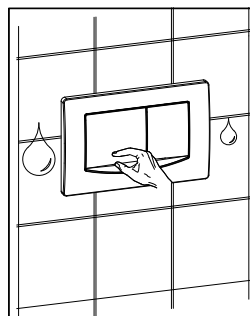

9. Verificați spălarea apăsând pe butonul de spălare cu jumătate de rezervor și cu un rezervor complet



Wellis®

CE