

Wellis®

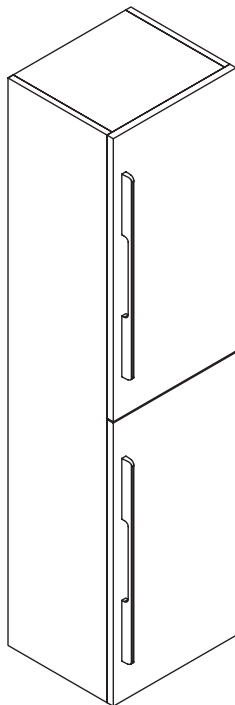

EN

Nina Tower cabinet
INSTALLATION GUIDE

DE

Nina Tower Turmschrank
AUFBAUANLEITUNG

FR

Nina Tower cabinet de tour
GUIDE D'INSTALLATION

HU

Nina Tower magas szekrény
TELEPÍTÉSI ÚTMUTATÓ

RO

Dulap înalt Nina Tower
INSTRUCȚIUNI DE MONTARE

NINA TOWER

WB00286

EN

Important information
Read carefully. Keep this information for
further referen-ce.

WARNING

Serious or fatal crushing injuries can occur from furniture tipover. To prevent this furniture from tipping over it must be permanently fixed to the wall. Fixing devices for the wall are not included since different wall materials require different types of fixing devices. Use fixing devices suitable for the walls in your home. For advice on suitable fixing systems, contact your local specialized dealer.

If you are uncertain about the ability of wall to support heavy weights, you can secure the cabinet at one or more additional points.

FR

Information importante
A lire attentivement. Conserver ces
informations pour un usage ultérieur.

AVERTISSEMENT

Risque de blessure grave en cas de chute du meuble. Pour éviter que le meuble ne bascule, il faut le fixer au mur de façon permanente. Les fixations ne sont pas incluses car leur choix dépend du matériau du mur sur lequel est fixé le meuble. Utilisez des fixations adaptées au matériau du mur. Pour obtenir des conseils sur les fixations à utiliser, adressez-vous à un revendeur spécialisé.

Si vous n'êtes pas sûr que le mur soit suffisamment solide pour supporter de lourdes charges, vous pouvez fixer l'élément à un ou plusieurs endroits supplémentaires.

DE

Wichtige Information
Sorgfältig lesen Diese Information
aufbewahren

ACHTUNG

Wenn Möbelstücke umkippen, können ernste oder lebensgefährliche Verletzungen durch Einklemmen die Folge sein. Um zu verhindern, dass das Möbelstück umkippt, muss es fest an der Wand verankert werden. Beschläge für die Wandbefestigung sind nicht beige-packt, da sie von der jeweiligen Wandbeschaffenheit abhängig sind. Befestigungsbeschläge benutzen, die für die heimischen Wände geeignet sind. Bei diesbezüglichen Fragen den örtlichen Fachhandel zu Rate ziehen.

Bei Unsicherheit bezüglich der Tragfähigkeit der Wand bitte das Möbelstück an einer oder mehreren Stellen mit der rückwärtigen Leiste an der Wand zu befestigen.

HU

Fontos információ
Kérjük, olvassa el alaposan, és őrizze meg ezt a papírt!

FIGYELEM!

A bútor felborulása, leszakadása súlyos, vagy akár végzetes balesetet okozhat. Ahhoz, hogy ezt megakadályozza, a bútort megfelelően a falhoz kell rögzíteni. A rögzítéshez szükséges kellékek nincsenek a csomagban, mivel a különböző típusú falakhoz különböző rögzítő eszközökre van szükség. Mindig a fal típusának megfelelő szerelvényeket használj! A megfelelő rögzítők kiválasztásához fordulj segítségért a szaküzletek munkatársaihoz!

Ha nem biztos benne, hogy a fal meg tudja tartani a nagy súlyt, megerősítheti a szekrényt további pontokon is.

RO

Informații importante
Vă rugăm să citiți cu atenție și păstrați
instrucțiunile!







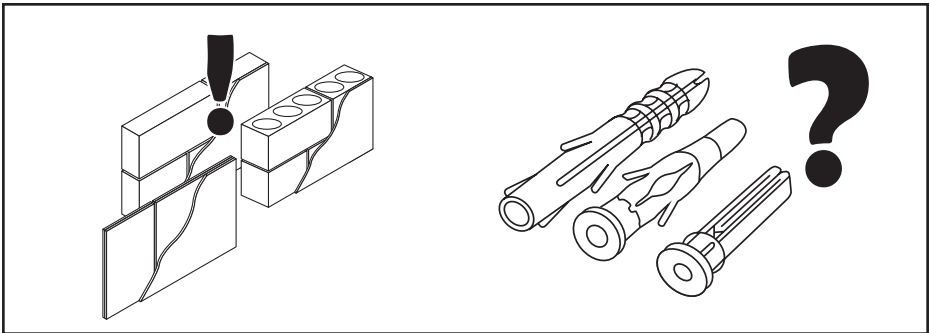
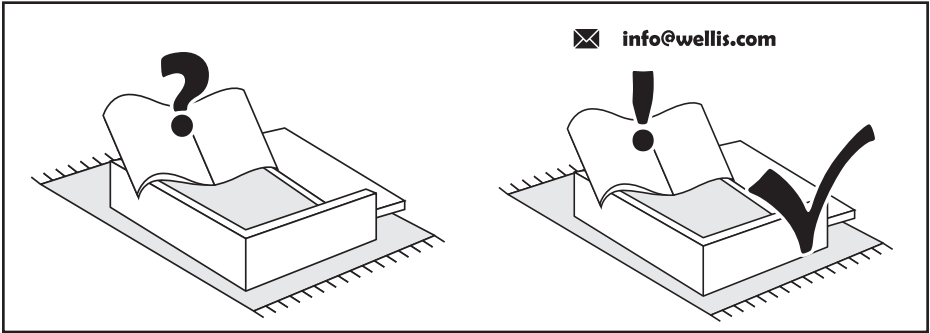
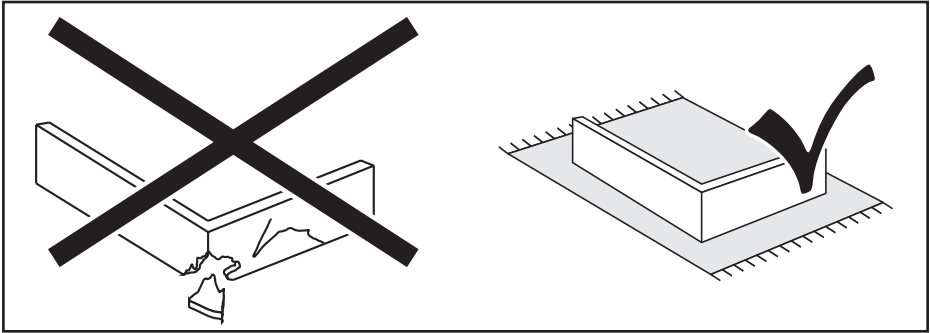
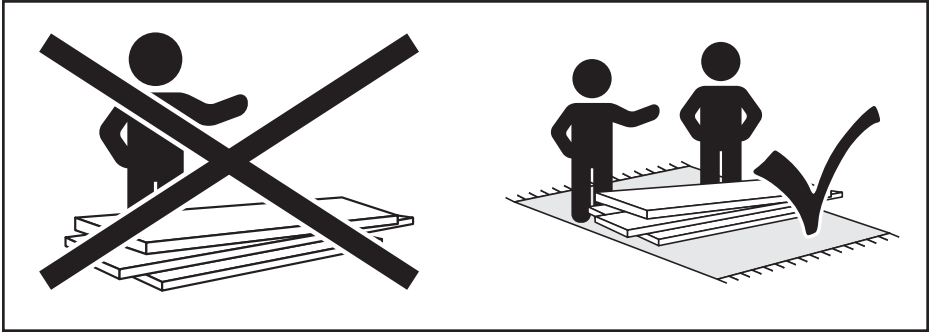

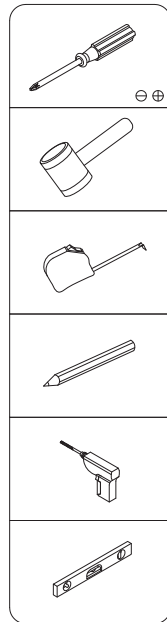
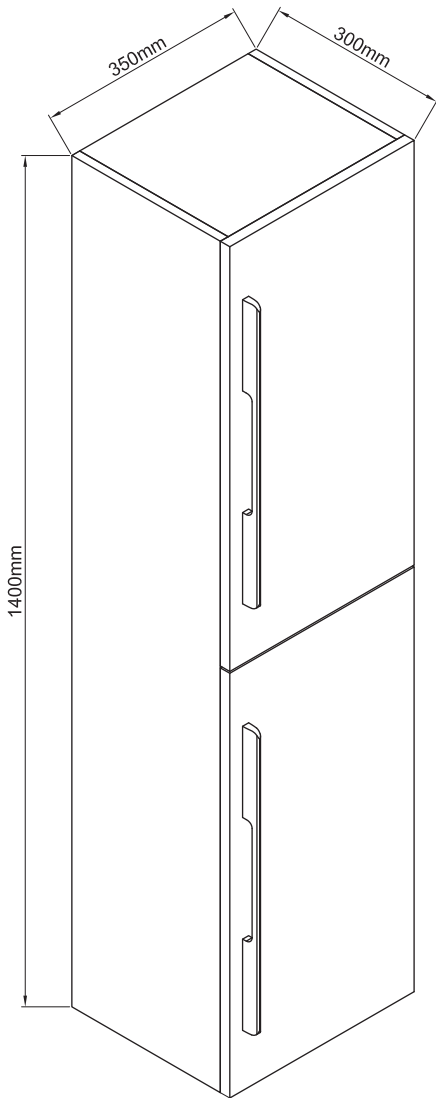

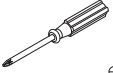







ATENȚIE!

Căderea sau ruperea mobilei poate cauza răniri sau chiar decesul. Pentru a împiedica acest lucru, mobila trebuie ancorată de perete în mod corespunzător. Pachetul nu conține accesoriile necesare pentru ancorare, deoarece acestea diferă în funcție de materialul peretelui. Utilizați întotdeauna accesorii corespunzătoare tipului de perete! Pentru alegerea elementelor de fixare corespunzătoare apălați la angajații magazinelor de profil!

Dacă nu sunteți sigur despre faptul că peretele nu suportă greutatea montată, mobila poate fi fixată în mai multe puncte.





 <small>⊖ ⊕</small>	<small>Ø4x14mm</small>  A1x24
	 B1x22
	<small>Ø8x30mm</small>  B2x20
	 B3x22
	 C1x8
	 D1x4
	<small>Ø8x40mm</small>  E1x4
	 E2x4
	<small>Ø5,5x60mm</small>  E3x4
	 E4x4
	 F1x2
	<small>Ø4x22mm</small>  F2x4

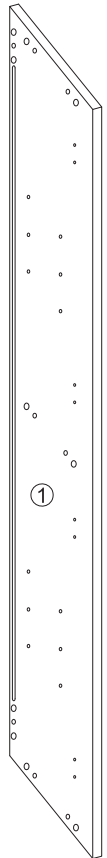
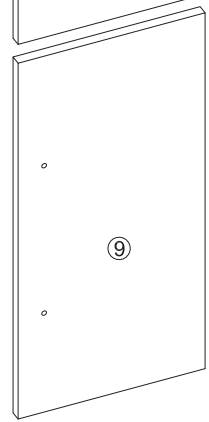
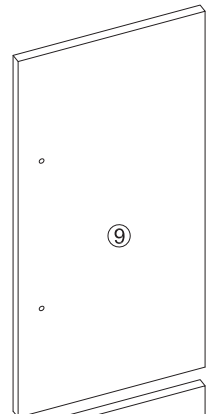
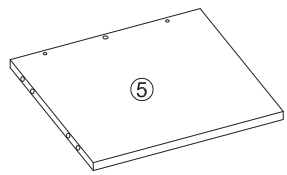
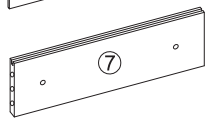
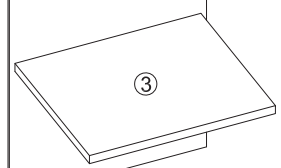
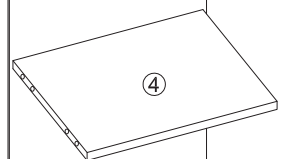
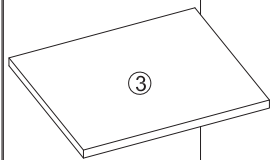
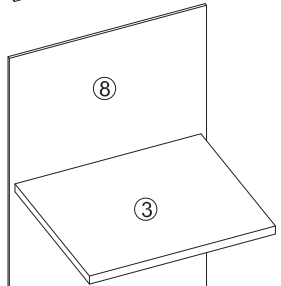
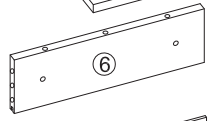
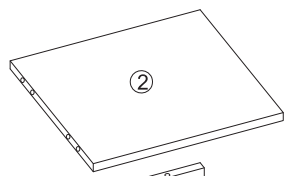
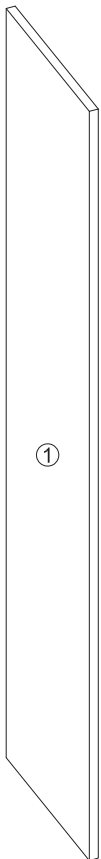

1

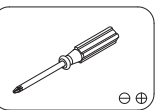
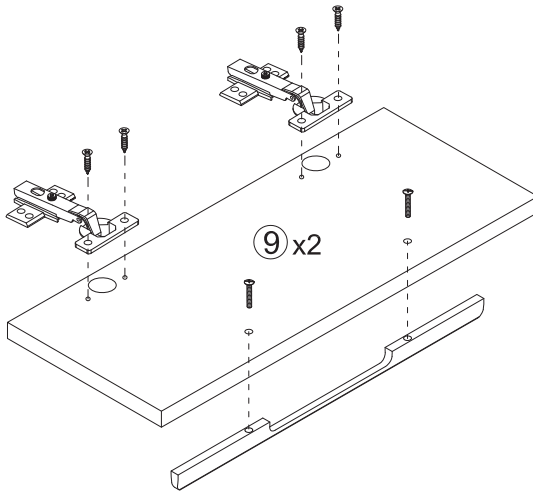

Ø4x14mm



A1x8



D1x4



F1x2

Ø4x22mm



F2x4

2

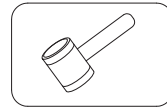

B1x20



C1x8

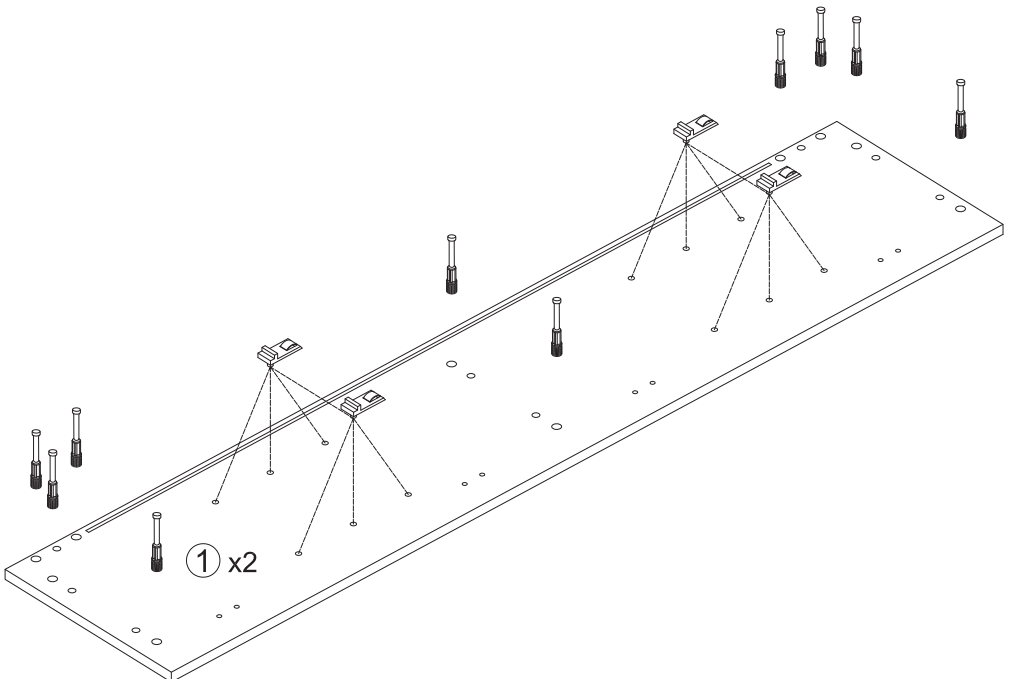

3

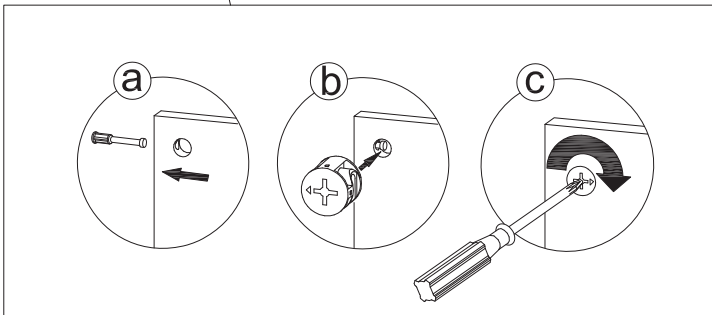
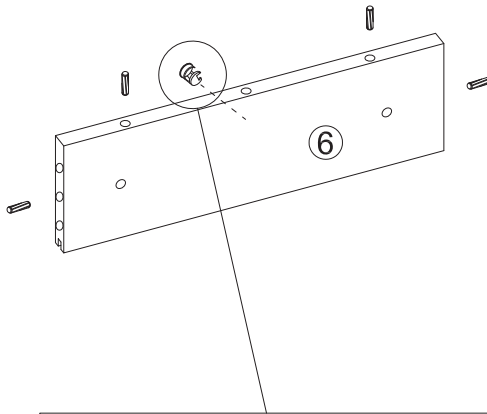
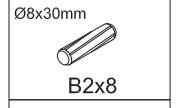
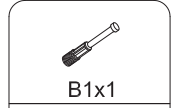
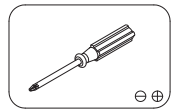
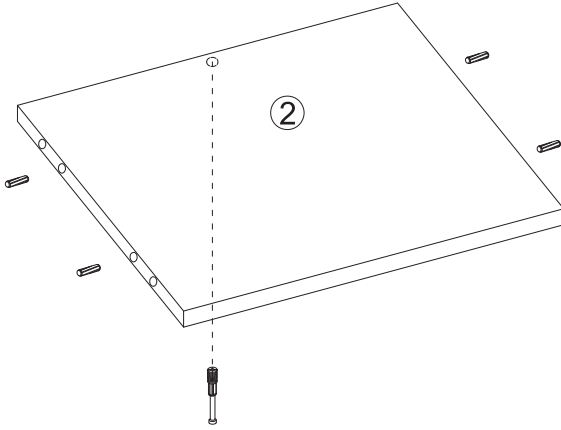

4

Ø8x30mm

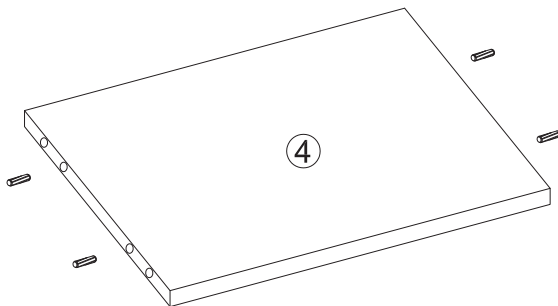
B2x4

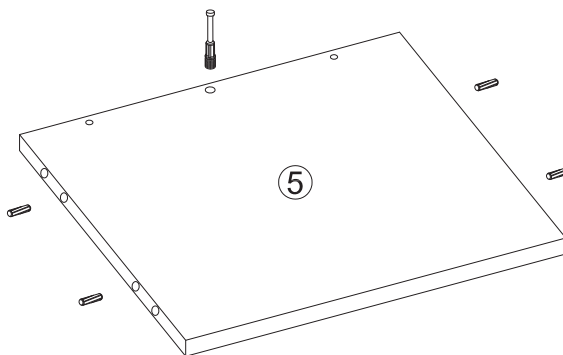
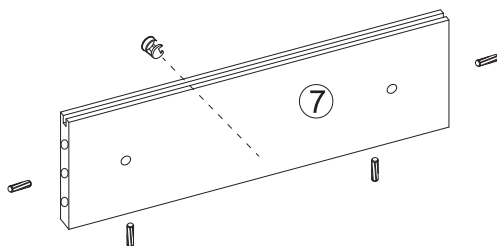
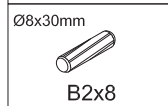
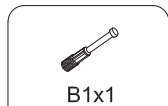
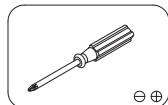

5

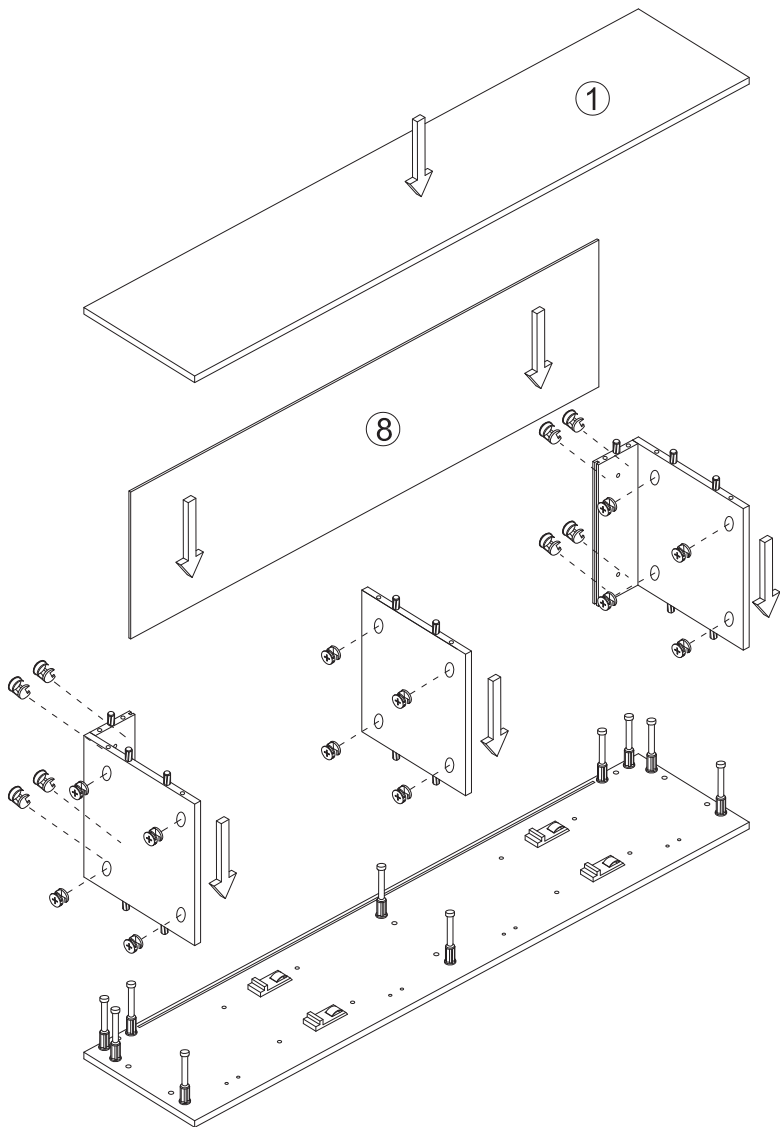
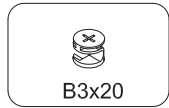
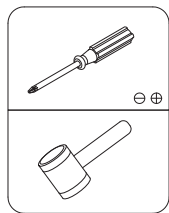

7



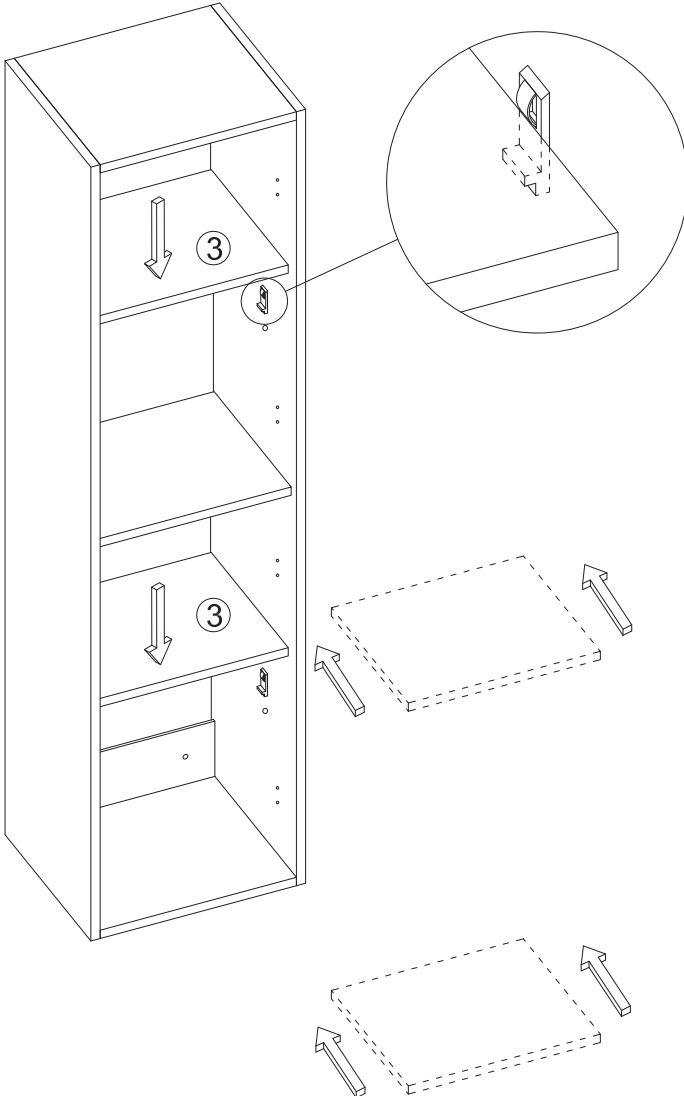

9

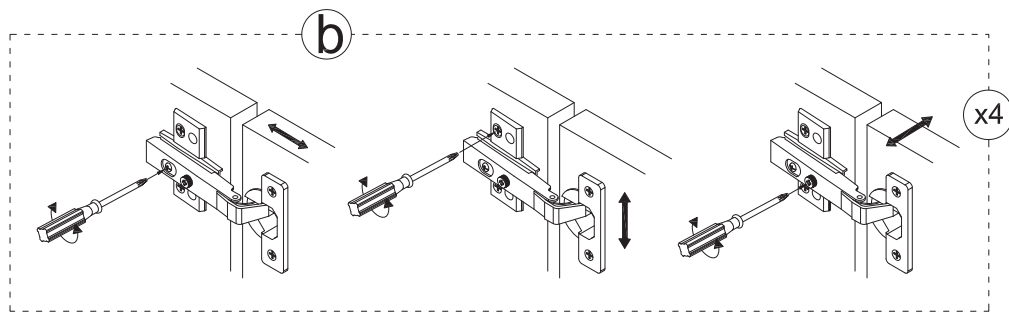
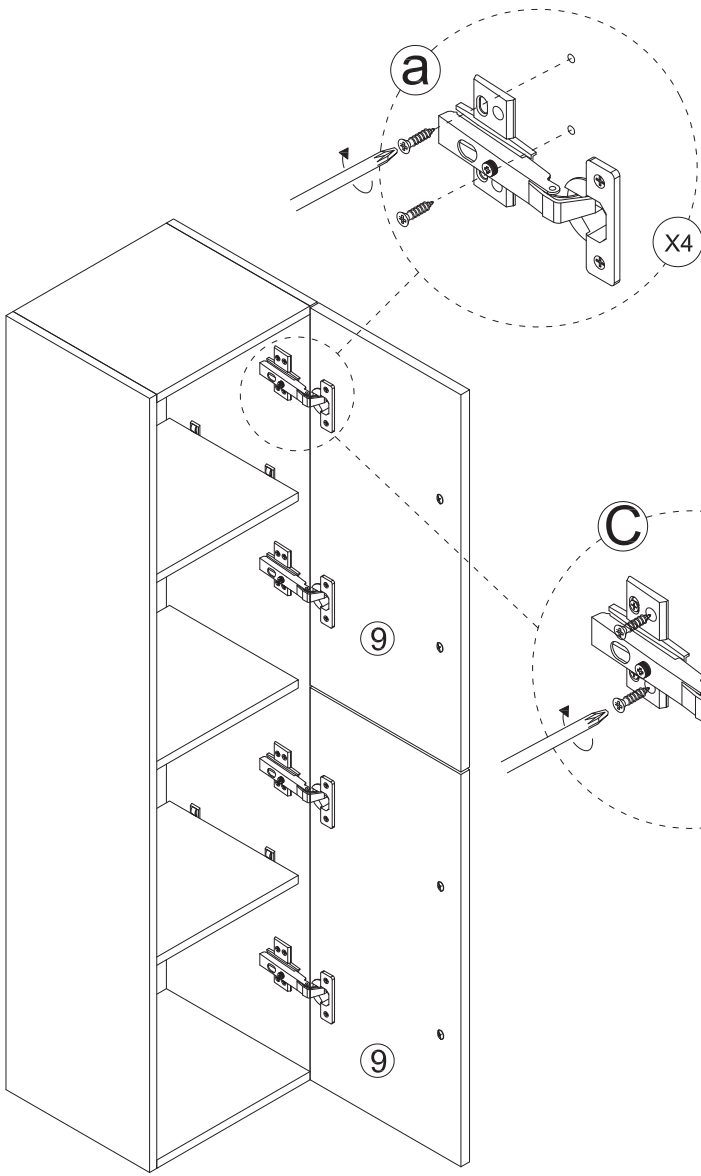
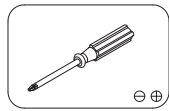

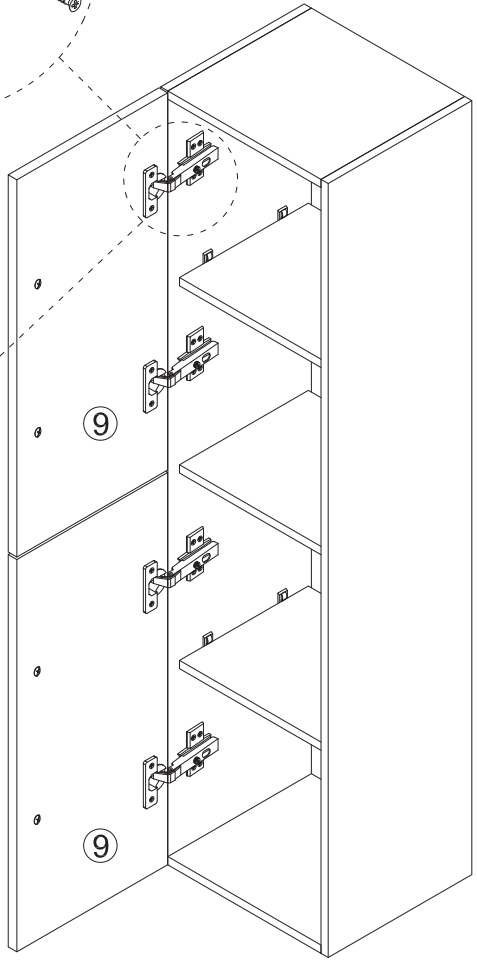
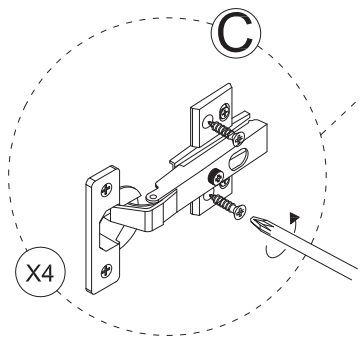
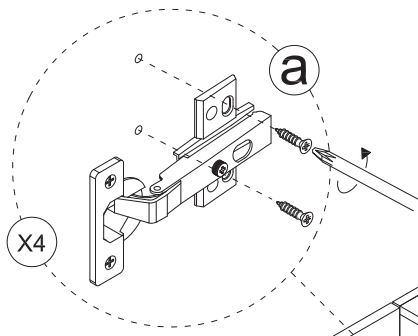

b

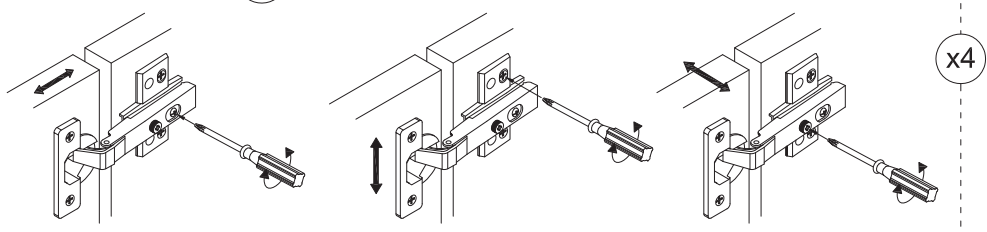

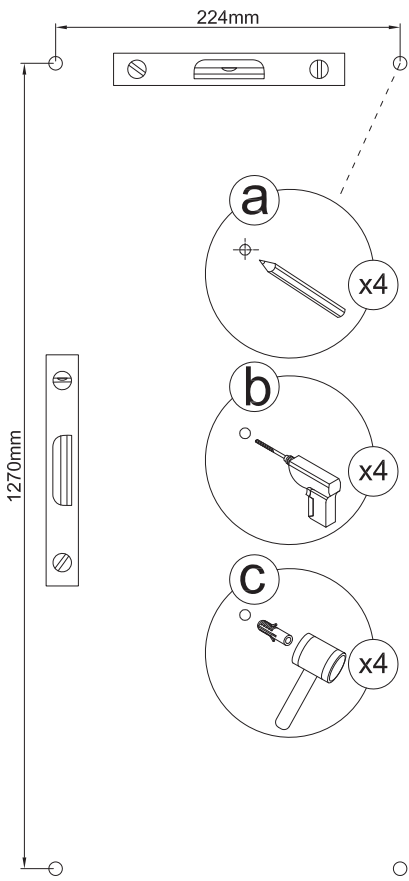
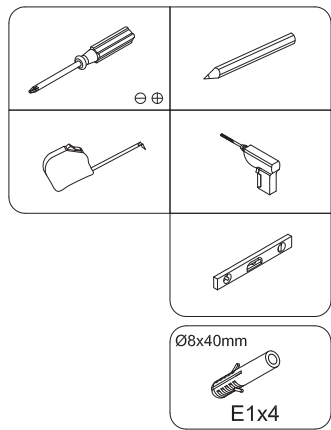

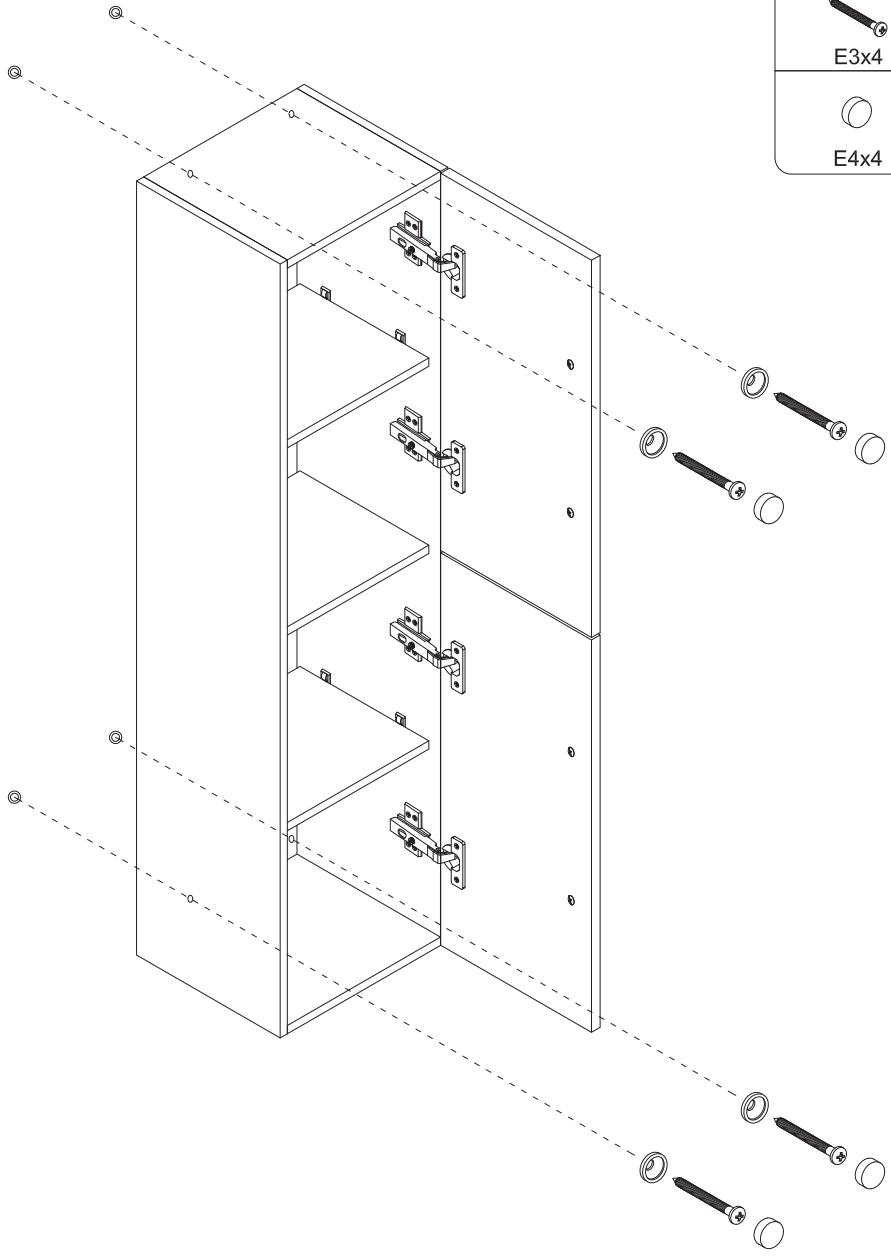
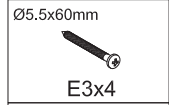
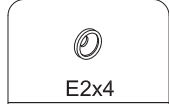
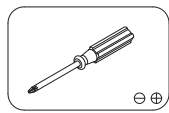

Wellis®

CE